

タダノ オールテレーンクレーン

ATF360G-6 型

仕 様 書

型式呼称	ATF-360G6
キャリヤ	FAUN RTF360G-6
スペック番号	ATF-360G-1-90102

株式会社 タダノ

ATF360G-6型 オールテレーンクレーン

1. 主要諸元

◎ クレーン

クレーン容量

ブーム	15.0 m	ブーム	170,000 kg	×	5.0 m	(18 本掛)
	20.1 m	ブーム	170,000 kg	×	5.0 m	(18 本掛)
	25.1 m	ブーム	157,000 kg	×	6.0 m	(16 本掛)
	30.2 m	ブーム	131,000 kg	×	6.0 m	(13 本掛)
	35.3 m	ブーム	109,800 kg	×	6.0 m	(11 本掛)
	40.4 m	ブーム	75,000 kg	×	9.0 m	(7 本掛)
	45.4 m	ブーム	63,400 kg	×	10.0 m	(6 本掛)
	50.5 m	ブーム	48,300 kg	×	12.0 m	(5 本掛)
	55.6 m	ブーム	40,000 kg	×	12.0 m	(4 本掛)
	60.0 m	ブーム	30,700 kg	×	16.0 m	(3 本掛)
		シングルトップ	11,300 kg			(1 本掛)
フルオートラフィングジブ	1.6m + 10.3m	ジブ	39,900 kg	×	9.0 m	(4 本掛)
	1.6m + 17.2m	ジブ	16,700 kg	×	26.0 m	(2 本掛)
	1.6m + 24.1m	ジブ	16,100 kg	×	14.0 m	(2 本掛)
	1.6m + 31.0m	ジブ	10,900 kg	×	16.0 m	(1 本掛)
ラフィングジブ	2.1 m + 20 m	ジブ	64,000 kg	×	16.0 m	(6 本掛)
	2.1 m + 29 m	ジブ	47,000 kg	×	20.0 m	(5 本掛)
	2.1 m + 38 m	ジブ	35,000 kg	×	30.0 m	(4 本掛)
	2.1 m + 47 m	ジブ	26,000 kg	×	24.0 m	(3 本掛)
ラフィングジブ+						
エクステンションジブ	2.1m+47m+	9mジブ	16,800 kg	×	22.0 m	(2 本掛)
	2.1m+47m+	17mジブ	9,800 kg	×	28.0 m	(1 本掛)
	2.1m+47m+	25mジブ	6,300 kg	×	40.0 m	(1 本掛)
T R A + ブーム	35.3 m	ブーム	109,800 kg	×	8.0 m	(11 本掛)
	40.4 m	ブーム	75,000 kg	×	12.0 m	(7 本掛)
	45.4 m	ブーム	65,000 kg	×	14.0 m	(6 本掛)
	50.5 m	ブーム	51,000 kg	×	14.0 m	(5 本掛)
	55.6 m	ブーム	41,800 kg	×	8.0 m	(4 本掛)
	60.0 m	ブーム	32,400 kg	×	18.0 m	(3 本掛)
		シングルトップ	11,300 kg			(1 本掛)
T R A +						
フルオートラフィングジブ	1.6m + 10.3m	ジブ	38,300 kg	×	10.0 m	(4 本掛)
	1.6m + 17.2m	ジブ	16,700 kg	×	32.0 m	(2 本掛)
	1.6m + 24.1m	ジブ	16,700 kg	×	12.0 m	(2 本掛)
	1.6m + 31.0m	ジブ	10,900 kg	×	18.0 m	(1 本掛)

TRA+ラフィングジブ	2.1 m + 20 m ジブ	34,600 kg × 26.0 m (4本掛)
	2.1 m + 29 m ジブ	24,700 kg × 32.0 m (3本掛)
	2.1 m + 38 m ジブ	16,900 kg × 44.0 m (2本掛)
	2.1 m + 47 m ジブ	11,200 kg × 50.0 m (2本掛)
TRA+ラフィングジブ +エクステンションジブ	2.1m+47m+ 9mジブ	6,900 kg × 62.0 m (1本掛)
	2.1m+47m+17mジブ	4,600 kg × 78.0 m (1本掛)
	2.1m+47m+25mジブ	3,000 kg × 90.0 m (1本掛)
最大地上揚程	ブー ム	60 m
	フルオートラフィングジブ	92 m
	ラフィングジブ	99 m
	ラフィングジブ+ エクステンションジブ	122 m
最大作業半径	ブー ム	58.0 m
	フルオートラフィングジブ	62.0 m
	ラフィングジブ	70.0 m
	ラフィングジブ+ エクステンションジブ	90.0 m
	TRA+ブー ム	56.0 m
	TRA+ フルオートラフィングジブ	70.0 m
	TRA+ラフィングジブ	74.0 m
	TRA+ラフィングジブ +エクステンションジブ	90.0 m
ブー ム 長さ		15.0 m ~ 60.0 m
ブー ム 伸縮長さ		45.0 m
ブー ム 伸長時間		400 s
ジブ 長さ	フルオートラフィングジブ	1.6 m + 10.3 m ~ 31.0 m
	ラフィングジブ	2.1 m + 20 m、29 m、38 m、47 m
	ラフィングジブ+ エクステンションジブ	2.1 m + 47 m + 9 m、17 m、25 m
主巻ロープ巻上げ速度		125 m/min (5層)
主巻フック巻上げ速度		6.9 m/min (18本掛)
		125 m/min (5層)
補巻フック巻上げ速度		125 m/min (1本掛)

ブーム起伏角度		0° ~ 84.5°
ブーム上げ時間		90 s
旋回角度		360° 連続
旋回速度		1.2 min ⁻¹
ワイヤロープ	主	巻 径 23 mm × 長さ 350 m 非自転性ワイヤロープ
	補	巻 径 23 mm × 長さ 510 m 非自転性ワイヤロープ
フック		170 t 吊 (18 本掛) 80 t 吊 (7 本掛) 25 t 吊 (3 本掛) 11.3 t 吊 (1 本掛)
ブーム形式		箱型 5 段油圧伸縮式 各段ピンロック方式
ブーム伸縮装置		複動油圧シリンダ直押式 1 本 圧力補償付流量調整弁付
フルオートラフィングジブ形式		箱型 4 段同時伸縮式 オフセット 5° ~ 60° 油圧無段階傾斜式
フルオートラフィングジブ伸縮装置		複動油圧シリンダ直押式 1 本 ワイヤロープ式伸縮装置 2 基
ラフィングジブ形式		ラチス型 オフセット油圧無段階傾斜式
エクステンションジブ形式		ラチス型 オフセット固定式
シングルトップ形式		先端ブーム取付横折曲格納式
巻上装置		油圧モータ駆動遊星歯車減速式 自動ブレーキ 高低速切換装置付 シングルウインチ 2 基 圧力補償付流量調整弁付
ブーム起伏装置		複動油圧シリンダ直押式 1 本 圧力補償付流量調整弁付
旋回装置		油圧モータ駆動遊星歯車減速式 ローラー式スイングベアリング 手動スイッチ式ブレーキ 油圧操作式旋回ロック
カウンタウエイト		138 t、118 t、98 t、78 t、58 t、47 t、 25 t、16.5 t、7.5 t、0 t
アウトリガ		全油圧式 H 型 最大張出幅 8.5m 中間張出幅 8.0m、6.8m、5.5m 最小張出幅 2.7m スライド・ジャッキ各個操作装置付 スライドロック用ピン付 スライド格納式フロート

動力取出方式		上部エンジン
	名称	ベンツ OM906LA
	形式	水冷4サイクル 直列6気筒直接噴射式 排気ターボ過給 インタークーラ付 ディーゼルエンジン
	総排気量	6.37 L
	最高出力	205 kW{278PS} / 2,200 min ⁻¹ {rpm}
	最大トルク	1,100 N·m{112kgf·m} / 1,200~1,600 min ⁻¹ {rpm}
燃料タンク容量		300 L
油圧ポンプ		高圧可変ピストンポンプ 2 高圧ピストンポンプ 1 高圧ギヤポンプ 1
作動油タンク油量		1,344 L
安全装置		過負荷防止装置 (AML) 作業範囲制限機能 旋回範囲制限機能 旋回自動停止機能 ブーム起伏緩停止機能 フック移動量表示機能 カウンタウエイト組み合わせ検出装置 個別検出式アウトリガ張出幅自動検出装置 巻過防止装置 捨巻確保装置 水準器 玉掛けロープはずれ止め 旋回ロック装置 油圧安全弁 油圧ロック装置 (伸縮・起伏・巻上・ジャッキ) ウインチドラム回転計
付属装置		カウンタウエイト着脱装置 ブーム、起伏装置着脱装置 速度調整装置 (起伏・旋回・ウインチ・フルオートラフィングジブチルト) 風速計 (ブーム、フルオートラフィングジブ、ラフィングジブ) リフトアジャスタ、リリースアジャスタ (ブーム、フルオートラフィングジブ) オイルクーラー AML外部表示灯 旋回音声警報装置 ドラム視認モニター 拡声器 クレーンキャブエアコン ラジオ

◎ キャリヤ

メーカ名	FAUN GmbH
キャリヤ型式	RTF360G-6
エンジン	ベンツ OM502LA
	水冷4サイクルV型8気筒直接噴射式 排気ターボ過給 インタークーラ付ディーゼルエンジン
	総排気量 15.928 L
	最高出力 448 kW{609PS} / 1,800 min ⁻¹ {rpm}
	最大トルク 2,700 N·m{275kgf·m} / 1,200 min ⁻¹ {rpm}
変速機形式	フルオートマチック 前進16段、後退2段
駆動方式	オンロード 12×6 オフロード 12×8 (デフロック機構付)
車軸形式	6軸全浮動式
懸架方式	全軸 hidroニューマチックサスペンション サスペンションストローク +165 mm -105 mm
ステアリング	形式 左ハンドル 全油圧式パワーステアリング 2系統式 非常用パワーステアリング付
	モード ノーマル (前6輪+後4輪) 特殊4種 (前6輪+後6輪)
ブレーキ	主ブレーキ 空気式全輪制動 2系統式 駐車ブレーキ 3、4、5、6軸 (8輪) 制動スプリング式 非常ブレーキ 駐車ブレーキと兼用 補助ブレーキ 変速機内蔵式流体式リターダ 排気ブレーキ
バッテリー	12V-170Ah × 2個 (24V)
燃料タンク容量	500 L
乗車定員	2人
タイヤ	445/95R25 177E ROAD (12輪)
ホイール	11.00-25 (12輪)
付属装置	集中給油装置 バックモニタ エアコン ラジオ マッドガード 仮眠用ベッド

◎ クレーン用台車諸元（公道走行状態）

全	長		15,460 mm
全	幅		3,000 mm
全	高		4,020 mm
軸	距		1,800 mm+3,150 mm+1,700 mm+2,440 mm+1,700mm
輪	距		2,540 mm
車	両	総重量	46,500 kg（乗車定員2人）
前	軸	重	1軸+2軸+3軸+4軸 27,390 kg
後	軸	重	5軸+6軸 19,110 kg
最	高	速度	85 km/h
登	坂	能力	(tan θ) 0.46
最	小	回転半径	11.9 m

公道走行時の注意事項

1. ブーム・起伏装置およびカウンタウエイト装置を別送し、クレーン用台車のみで走行しなければなりません。
2. 道路運送車両の保安基準による保安基準緩和の認定が必要です。
3. 道路法による特殊車両の通行許可が必要です。基本通行条件 重量：Dが記載された適合証明書を取得していますが、実際の通行経路で申請して許可された条件にしたがって走行しなければなりません。

2. ESPブーム定格総荷重表

1. 定格総荷重表の性能区分A～Qは、下表のとおりです。

カウンタ ウエイト アウトリガ 張出幅	138 t	118 t	98 t	78 t	58 t	47 t	25 t	16.5 t	7.5 t	0 t
8.5m	A	B	D	E	F	G	I	J	K	M
8.0m		C	D	E	F	G	I	J	K	M
6.8m				F	G	H	J	K	L	N
5.5m						I	K	L	M	O
2.7m										P, Q

※ 同じ性能区分・ブーム長さでも、ブームの伸長状態によって定格総荷重が異なります。

※ P, Q性能は、30.2mブームまでで、作業領域は下図のとおりです。

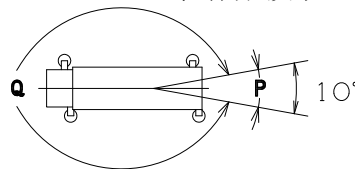

2. 定格総荷重は、つり具質量とフック質量（170トフック：3,200 kg、80トフック：1,270 kg、11.3トフック：440 kg）を含んだ値を示します。
3. 定格総荷重は、ブームのたわみを含んだ実際の作業半径に基づいています。
4. 定格総荷重表中の標準巻掛本数より少ない本数で使用する場合、最大荷重の上限は下表のとおりです。

巻掛本数	16本	14本	13本	11本	9本	8本	7本	6本	5本	4本	3本	1本
最大荷重	157.3t	140.3t	131.5t	113.5t	94.7t	85.0t	75.1t	65.0t	54.7t	44.2t	33.5t	11.3t

5. シングルトップ使用時の巻掛本数は1本（11.3トフック使用）で、定格総荷重はブームの定格総荷重からブームに取り付けられているフックの質量を差し引いた値とし、かつ上限は11.3tです。
6. 定格総荷重はアウトリガを水平堅土上に設置したときの値です。
7. 定格総荷重表は、風による影響を含んでいません。瞬間最大風速が10m/s以上の風速では、クレーン作業を中止してください。
8. 定格総荷重表中の太線より上側はクレーンの強度に、下側はクレーンの安定に基づいています。
9. 「ピン無最大荷重」は、Bピン（ブーム固定ピン）を挿入していないときの定格総荷重の上限を示します。
10. 「 θ （°）」は、無負荷状態で作動可能なブーム起伏角度範囲を示します。
11. 「補巻時・標準巻掛本数」は、補巻使用時の標準巻掛本数を示します。
12. 「主巻時・標準巻掛本数」は、主巻使用時の標準巻掛本数を示し、補巻よりもワイヤロープ長さが短いため、巻掛本数が少なくなる場合があります。
13. 「主巻時・最大荷重」は、主巻使用時の定格総荷重の上限を示します。

■A性能

ESPブーム

単位:t

性能ブロック 性能番号	1	3	1	3	5	4	2	1	4	2	1	4	6	2	1	2	1	7	9	8	1	10	11	1	1	12	
	1	14	2	15	19	16	10	3	17	11	4	18	20	12	5	13	6	21	23	22	7	24	25	8	9	26	
ブーム長さ(m) 作業半径(m)	15.0	20.1		25.1				30.2			35.3				40.4		45.4				50.5			55.6	60.0		
6.0	160.9																										
7.0	144.3	144.2	83.7	143.7	134.4	121.4	88.8	59.3																			
8.0	130.7	130.5	77.5	130.0	124.2	111.2	81.3	54.3	119.8	87.6	55.8																
9.0	119.3	119.1	72.2	118.6	115.4	102.6	74.9	50.0	111.4	81.4	51.3	83.9	84.3	86.0	45.8												
10.0	109.5	109.3	67.6	108.9	107.8	94.7	69.5	46.3	104.1	76.1	47.4	76.3	76.8	80.8	42.3	73.7	45.2	63.4	60.3	56.6	46.7	48.3	47.8	43.5	40.0	30.7	
11.0	101.1	100.9	63.6	100.3	100.9	87.7	64.8	43.2	97.7	71.4	44.1	69.9	70.4	76.2	39.3	67.5	42.2	61.1	57.2	53.4	43.9	48.3	47.8	43.5	40.0	30.7	
12.0	86.6	92.8	60.2	92.2	92.8	81.7	60.7	40.4	92.1	67.2	41.2	64.4	64.9	72.1	36.6	62.2	39.6	57.6	54.5	50.6	41.4	48.3	47.8	42.8	40.0	30.7	
14.0		79.3	54.5	78.6	79.2	71.7	53.9	35.8	79.4	60.2	36.4	55.5	56.0	65.1	32.2	53.6	35.1	51.3	49.7	45.7	37.0	45.7	45.8	38.6	39.7	30.7	
16.0		66.7	50.2	68.1	68.7	63.9	48.5	32.2	68.9	54.6	32.6	48.5	49.0	59.5	28.7	46.9	31.6	44.8	45.1	41.7	33.5	41.3	41.5	35.2	36.3	30.7	
18.0		41.6	43.1	59.8	60.5	57.6	44.2	29.2	60.6	50.0	29.5	42.9	43.4	54.7	25.9	41.5	28.7	39.5	39.9	38.3	29.8	37.7	38.0	32.3	33.5	28.8	
20.0				52.4	53.1	51.7	40.5	26.3	53.9	45.2	26.6	38.3	38.8	50.7	23.6	37.1	26.2	35.3	35.6	35.5	26.7	34.1	34.5	29.8	31.1	26.1	
22.0				40.4	41.0	41.9	36.8	24.0	48.4	40.9	24.1	34.5	35.0	47.4	21.6	33.4	24.2	31.7	32.1	32.5	24.1	30.7	31.1	27.3	29.0	24.0	
24.0									43.7	37.3	22.1	31.3	31.8	44.4	19.9	30.3	22.4	28.7	29.1	29.5	21.9	27.9	28.2	24.9	27.1	22.1	
26.0									36.1	34.3	20.3	28.6	29.1	40.7	18.5	27.7	20.7	26.1	26.5	26.9	20.0	25.4	25.7	22.8	24.8	20.5	
28.0									23.5	25.1	18.9	26.2	26.7	36.9	17.3	25.4	19.0	23.9	24.3	24.7	18.4	23.2	23.5	21.0	22.7	19.3	
30.0												24.2	24.7	32.2	16.0	23.4	17.5	21.9	22.3	22.8	17.0	21.3	21.6	19.4	20.9	18.2	
32.0												22.5	23.0	25.2	14.9	21.6	16.2	20.2	20.6	21.1	15.7	19.6	20.0	18.0	19.3	17.3	
34.0																20.1	15.1	18.7	19.1	19.6	14.6	18.1	18.5	16.8	17.9	16.5	
36.0																18.7	14.1	17.4	17.7	18.2	13.6	16.8	17.1	15.7	16.7	15.6	
38.0																15.1	13.3	16.2	16.5	17.0	12.8	15.6	16.0	14.7	15.5	14.6	
40.0																		15.1	15.5	15.9	12.0	14.6	14.9	13.8	14.5	13.7	
42.0																		14.1	14.5	15.0	11.3	13.6	13.9	13.1	13.5	12.9	
44.0																						12.7	13.1	12.3	12.7	12.2	
46.0																						11.9	12.3	11.6	11.9	11.5	
48.0																						10.7	10.9	11.0	11.2	10.7	
50.0																									10.5	10.0	
52.0																									9.9	9.4	
54.0																										8.8	
56.0																										8.2	
58.0																										5.6	
ピン無最大荷重	62.0	65.4	70.3	61.8		60.6	68.2	50.4	60.8	64.3	55.8	53.3		60.9	45.8	52.2	45.2	49.5		53.5	46.7	45.2		43.5	40.0	30.7	
θ (°)	0 ~ 67		0 ~ 71		0 ~ 74				0 ~ 75			0 ~ 77				0 ~ 78		0 ~ 80				0 ~ 81			0 ~ 83	0 ~ 84.5	
伸 長 状 態 (伸長割合%)																											
伸縮ブーム1	0	0	0	45	45	0	0	0	45	0	0	90	90	45	0	90	0	90	90	90	0	90	90	45	90	100	
伸縮ブーム2	0	45	0	45	0	45	0	0	45	45	0	45	45	45	0	45	45	90	90	45	90	90	90	90	90	100	
伸縮ブーム3	0	0	0	0	45	45	45	0	45	45	45	45	0	45	90	45	90	45	0	45	90	90	45	90	90	100	
伸縮ブーム4	0	0	45	0	0	0	45	90	0	45	90	0	45	45	90	45	90	45	90	90	90	45	90	90	90	100	
標準フック	170t	170t		170t				80t	170t	80t	170t				80t	80t				80t				80t	80t	80t	
フック質量	3200kg	3200kg		3200kg				1270kg	3200kg	1270kg	3200kg				1270kg	1270kg				1270kg				1270kg	1270kg		
補巻時・標準巻掛本数	18	16	8	16	14	13	9	6	13	9	6	8		9	5	7	5	6		5	5	5	4	4	3		
主巻時・標準巻掛本数	18	14	8	11			9	6	9		6	8				5	6	5	6		5	5	4	4	3		
主巻時・最大荷重	160.9	140.3	83.7	113.5			88.8	59.3	94.7	87.6	55.8	83.9	84.3	85.0	45.8	65.0	45.2	63.4	60.3	56.6	46.7	48.3	47.8	43.5	40.0	30.7	

注)カウンタウエイト 138t、アウトリガ張出幅 8.5m

■B性能

ESPブーム

単位:t

性能ブロック	1	3	1	3	5	4	2	1	4	2	1	4	6	2	1	2	1	7	9	8	1	10	11	1	1	12			
性能番号	1	14	2	15	19	16	10	3	17	11	4	18	20	12	5	13	6	21	23	22	7	24	25	8	9	26			
ブーム長さ(m)	15.0		20.1			25.1						30.2			35.3				40.4			45.4				50.5		55.6	60.0
作業半径(m)	170.0																												
3.0	170.0																												
3.5	170.0	170.0	117.6																										
4.0	170.0	170.0	111.1	157.0	139.0	139.0	116.6	82.5	131.0	119.4	85.5																		
4.5	170.0	170.0	105.3	157.0	139.0	139.0	111.4	77.5	131.0	114.6	80.2																		
5.0	170.0	170.0	100.1	157.0	139.0	139.0	106.6	73.0	131.0	110.2	75.5	109.8	109.4	100.9	67.9														
6.0	159.0	158.8	91.1	157.0	139.0	133.7	97.9	65.5	131.0	102.4	67.6	109.8	108.1	100.9	60.7	75.0	62.7												
7.0	142.6	142.4	83.7	142.0	134.4	121.4	88.8	59.3	129.5	94.9	61.1	103.9	101.6	98.7	54.8	75.0	57.2	63.4	62.7	60.3	51.3								
8.0	129.1	128.9	77.5	128.4	124.2	111.2	81.3	54.3	119.8	87.6	55.8	92.9	93.4	91.9	49.9	75.0	52.6	63.4	62.7	60.3	51.3	48.3	47.8	43.5					
9.0	117.7	117.5	72.2	117.0	115.4	102.6	74.9	50.0	111.4	81.4	51.3	83.9	84.3	86.0	45.8	75.0	48.6	63.4	62.7	60.1	50.0	48.3	47.8	43.5	40.0				
10.0	106.8	106.5	67.6	106.0	106.6	94.7	69.5	46.3	104.1	76.1	47.4	76.3	76.8	80.8	42.3	73.7	45.2	63.4	60.3	56.6	46.7	48.3	47.8	43.5	40.0	30.7			
11.0	97.2	97.0	63.6	96.4	97.0	87.7	64.8	43.2	97.2	71.4	44.1	69.9	70.4	76.2	39.3	67.5	42.2	61.1	57.2	53.4	43.9	48.3	47.8	43.5	40.0	30.7			
12.0	86.6	88.8	60.2	88.2	88.8	81.7	60.7	40.4	89.0	67.2	41.2	64.4	64.9	72.1	36.6	62.2	39.6	57.6	54.5	50.6	41.4	48.3	47.8	42.8	40.0	30.7			
14.0		75.6	54.5	74.9	75.6	71.7	53.9	35.8	75.7	60.2	36.4	55.5	56.0	65.1	32.2	53.6	35.1	51.3	49.7	45.7	37.0	45.7	45.8	38.6	39.7	30.7			
16.0		65.6	50.2	64.9	65.5	63.9	48.5	32.2	65.6	54.6	32.6	48.5	49.0	59.5	28.7	46.9	31.6	44.8	45.1	41.7	33.5	41.3	41.5	35.2	36.3	30.7			
18.0		41.6	43.1	56.9	57.6	57.6	44.2	29.2	57.7	50.0	29.5	42.9	43.4	54.7	25.9	41.5	28.7	39.5	39.9	38.3	29.8	37.7	38.0	32.3	33.5	28.8			
20.0				49.3	50.1	51.0	40.5	26.3	50.2	45.2	26.6	38.3	38.8	50.7	23.6	37.1	26.2	35.3	35.6	35.5	26.7	34.1	34.5	29.8	31.1	26.1			
22.0				40.4	41.0	41.9	36.8	24.0	43.8	40.9	24.1	34.5	35.0	44.9	21.6	33.4	24.2	31.7	32.1	32.5	24.1	30.7	31.1	27.3	29.0	24.0			
24.0										38.7	37.3	22.1	31.3	31.8	39.7	19.9	30.3	22.4	28.7	29.1	29.5	21.9	27.9	28.2	24.9	27.1	22.1		
26.0										34.6	34.3	20.3	28.6	29.1	35.5	18.5	27.7	20.7	26.1	26.5	26.9	20.0	25.4	25.7	22.8	24.8	20.5		
28.0										23.5	25.1	18.9	26.2	26.7	32.0	17.3	25.4	19.0	23.9	24.3	24.7	18.4	23.2	23.5	21.0	22.7	19.3		
30.0												24.2	24.7	29.0	16.0	23.4	17.5	21.9	22.3	22.8	17.0	21.3	21.6	19.4	20.9	18.2			
32.0												22.5	23.0	25.2	14.9	21.6	16.2	20.2	20.6	21.1	15.7	19.6	20.0	18.0	19.3	17.3			
34.0																20.1	15.1	18.7	19.1	19.6	14.6	18.1	18.5	16.8	17.9	16.5			
36.0																18.7	14.1	17.4	17.7	18.2	13.6	16.8	17.1	15.7	16.7	15.6			
38.0																15.1	13.3	16.2	16.5	17.0	12.8	15.6	16.0	14.7	15.5	14.6			
40.0																		15.1	15.5	15.9	12.0	14.6	14.9	13.8	14.5	13.7			
42.0																		14.1	14.5	15.0	11.3	13.6	13.9	13.1	13.5	12.9			
44.0																						12.7	13.1	12.3	12.7	12.2			
46.0																						11.9	12.3	11.6	11.9	11.5			
48.0																						10.7	10.9	11.0	11.2	10.7			
50.0																									10.5	10.0			
52.0																									9.9	9.4			
54.0																										8.8			
56.0																										8.2			
58.0																										5.6			
ピン無最大荷重	62.0	65.4	70.3	61.8			60.6	68.2	50.4	60.8	64.3	67.0	53.3		60.9	52.0	52.2	62.1	49.5		53.5	51.3	45.2		43.5	40.0	30.7		
θ(°)	0~80		0~80			0~81						0~83			0~84.5				0~84			0~84.5				0~84.5		0~84.5	

伸長状態(伸長割合%)

伸縮ブーム1	0	0	0	45	45	0	0	0	45	0	0	90	90	45	0	90	0	90	90	90	0	90	90	45	90	100
伸縮ブーム2	0	45	0	45	0	45	0	0	45	45	0	45	45	45	0	45	45	90	90	45	90	90	90	90	90	100
伸縮ブーム3	0	0	0	0	45	45	45	0	45	45	45	45	0	45	90	45	90	45	0	45	90	90	45	90	90	100
伸縮ブーム4	0	0	45	0	0	0	45	90	0	45	90	0	45	45	90	45	90	45	90	90	90	45	90	90	90	100
標準フック	170t	170t		170t						170t			170t		80t	80t		80t				80t		80t	80t	
フック質量	3200kg	3200kg		3200kg						3200kg			3200kg		1270kg	1270kg		1270kg				1270kg		1270kg	1270kg	
補巻時・標準巻掛本数	18	18	13	16	14	13	8	13	9			11	7	7	6			6		5	5	4	4	3		
主巻時・標準巻掛本数	18	14	13		11		8		9			8	7	6			6		5		5	4	4	3		
主巻時・最大荷重	170.0	140.3	117.6	113.5			82.5	94.7	85.5			85.0	67.9	65.0	62.7	63.4	62.7	60.3	51.3	48.3	47.8	43.5	40.0	30.7		

注)カウンタウエイト 118t、アウトリガ張出幅 8.5m

■C性能

ESPブーム

単位:t

性能ブロック	1	3	1	3	5	4	2	1	4	2	1	4	6	2	1	2	1	7	9	8	1	10	11	1	1	12
性能番号	1	14	2	15	19	16	10	3	17	11	4	18	20	12	5	13	6	21	23	22	7	24	25	8	9	26
ブーム長さ(m) 作業半径(m)	15.0	20.1		25.1				30.2				35.3				40.4		45.4				50.5			55.6	60.0
3.0	170.0																									
3.5	170.0	170.0	117.6																							
4.0	170.0	170.0	111.1	157.0	139.0	139.0	116.6	82.5																		
4.5	170.0	170.0	105.3	157.0	139.0	139.0	111.4	77.5																		
5.0	170.0	170.0	100.1	157.0	139.0	139.0	106.6	73.0	131.0	110.2	75.5															
6.0	159.0	158.8	91.1	157.0	139.0	133.7	97.9	65.5	131.0	102.4	67.6	109.8	108.1	100.9	60.7	75.0	62.7									
7.0	142.6	142.4	83.7	142.0	134.4	121.4	88.8	59.3	129.5	94.9	61.1	103.9	101.6	98.7	54.8	75.0	57.2	63.4	62.7	60.3	51.3					
8.0	128.2	128.0	77.5	127.5	124.2	111.2	81.3	54.3	119.8	87.6	55.8	92.9	93.4	91.9	49.9	75.0	52.6	63.4	62.7	60.3	51.3	48.3	47.8	43.5		
9.0	115.6	115.4	72.2	114.9	115.4	102.6	74.9	50.0	111.4	81.4	51.3	83.9	84.3	86.0	45.8	75.0	48.6	63.4	62.7	60.1	50.0	48.3	47.8	43.5	40.0	
10.0	104.8	104.6	67.6	104.0	104.6	94.7	69.5	46.3	104.1	76.1	47.4	76.3	76.8	80.8	42.3	73.7	45.2	63.4	60.3	56.6	46.7	48.3	47.8	43.5	40.0	30.7
11.0	95.4	95.1	63.6	94.5	95.1	87.7	64.8	43.2	95.3	71.4	44.1	69.9	70.4	76.2	39.3	67.5	42.2	61.1	57.2	53.4	43.9	48.3	47.8	43.5	40.0	30.7
12.0	86.6	87.1	60.2	86.5	87.1	81.7	60.7	40.4	87.3	67.2	41.2	64.4	64.9	72.1	36.6	62.2	39.6	57.6	54.5	50.6	41.4	48.3	47.8	42.8	40.0	30.7
14.0		74.1	54.5	73.5	74.1	71.7	53.9	35.8	74.3	60.2	36.4	55.5	56.0	65.1	32.2	53.6	35.1	51.3	49.7	45.7	37.0	45.7	45.8	38.6	39.7	30.7
16.0		64.2	50.2	63.5	64.1	63.9	48.5	32.2	64.3	54.6	32.6	48.5	49.0	59.5	28.7	46.9	31.6	44.8	45.1	41.7	33.5	41.3	41.5	35.2	36.3	30.7
18.0		41.6	43.1	55.6	56.3	57.1	44.2	29.2	56.4	50.0	29.5	42.9	43.4	54.7	25.9	41.5	28.7	39.5	39.9	38.3	29.8	37.7	38.0	32.3	33.5	28.8
20.0				49.3	49.9	50.7	40.5	26.3	50.0	45.2	26.6	38.3	38.8	50.7	23.6	37.1	26.2	35.3	35.6	35.5	26.7	34.1	34.5	29.8	31.1	26.1
22.0				40.4	41.0	41.9	36.8	24.0	43.8	40.9	24.1	34.5	35.0	44.9	21.6	33.4	24.2	31.7	32.1	32.5	24.1	30.7	31.1	27.3	29.0	24.0
24.0									38.7	37.3	22.1	31.3	31.8	39.7	19.9	30.3	22.4	28.7	29.1	29.5	21.9	27.9	28.2	24.9	27.1	22.1
26.0									34.6	34.3	20.3	28.6	29.1	35.5	18.5	27.7	20.7	26.1	26.5	26.9	20.0	25.4	25.7	22.8	24.8	20.5
28.0									23.5	25.1	18.9	26.2	26.7	32.0	17.3	25.4	19.0	23.9	24.3	24.7	18.4	23.2	23.5	21.0	22.7	19.3
30.0												24.2	24.7	29.0	16.0	23.4	17.5	21.9	22.3	22.8	17.0	21.3	21.6	19.4	20.9	18.2
32.0												22.5	23.0	25.2	14.9	21.6	16.2	20.2	20.6	21.1	15.7	19.6	20.0	18.0	19.3	17.3
34.0																20.1	15.1	18.7	19.1	19.6	14.6	18.1	18.5	16.8	17.9	16.5
36.0																18.7	14.1	17.4	17.7	18.2	13.6	16.8	17.1	15.7	16.7	15.6
38.0																15.1	13.3	16.2	16.5	17.0	12.8	15.6	16.0	14.7	15.5	14.6
40.0																		15.1	15.5	15.9	12.0	14.6	14.9	13.8	14.5	13.7
42.0																		14.1	14.5	15.0	11.3	13.6	13.9	13.1	13.5	12.9
44.0																						12.7	13.1	12.3	12.7	12.2
46.0																						11.9	12.3	11.6	11.9	11.5
48.0																						10.7	10.9	11.0	11.2	10.7
50.0																									10.5	10.0
52.0																									9.9	9.4
54.0																										8.8
56.0																										8.2
58.0																										5.6

ピン無最大荷重	62.0	65.4	70.3	61.8				60.6	68.2	50.4	60.8	64.3	67.0	53.3		60.9	52.0	52.2	62.1	49.5		53.5	51.3	45.2		43.5	40.0	30.7	
θ (°)	0~76		0~79		0~81				0~81				0~83				0~83		0~84.5				0~84		0~84.5		0~84.5		0~84.5

伸 長 状 態 (伸長割合%)																												
伸縮ブーム1	0	0	0	45	45	0	0	0	45	0	0	90	90	45	0	90	0	90	90	90	0	90	90	45	90	100		
伸縮ブーム2	0	45	0	45	0	45	0	0	45	45	0	45	45	45	0	45	45	90	90	45	90	90	90	90	90	100		
伸縮ブーム3	0	0	0	0	45	45	45	0	45	45	45	45	0	45	90	45	90	45	0	45	90	90	45	90	90	100		
伸縮ブーム4	0	0	45	0	0	0	45	90	0	45	90	0	45	45	90	45	90	45	90	90	90	45	90	90	90	100		
標準フック	170t	170t		170t				170t				170t		80t	80t		80t				80t		80t	80t				
フック質量	3200kg	3200kg		3200kg				3200kg				3200kg		1270kg	1270kg		1270kg				1270kg		1270kg	1270kg				
補巻時・標準巻掛本数	18	18	13	16	14		13	8	13	11		8	11		6	7		6	6		5		5	4		4	3	
主巻時・標準巻掛本数	18	14	13	11				8		9		8		8		6		6				5		5		4	4	3
主巻時・最大荷重	170.0	140.3	117.6	113.5				82.5		94.7		75.5		85.0		60.7		65.0	62.7	63.4	62.7	60.3	51.3	48.3	47.8	43.5	40.0	30.7

注)カウンタウエイト 118t、アウトリガ張出幅 8.0m

■D性能

ESPブーム

単位:t

性能ブロック	1	3	1	3	5	4	2	1	4	2	1	4	6	2	1	2	1	7	9	8	1	10	11	1	1	12					
性能番号	1	14	2	15	19	16	10	3	17	11	4	18	20	12	5	13	6	21	23	22	7	24	25	8	9	26					
ブーム長さ(m)	15.0	20.1		25.1				30.2				35.3				40.4		45.4				50.5			55.6	60.0					
作業半径(m)	170.0	170.0		170.0				170.0				170.0				170.0		170.0				170.0			170.0	170.0					
3.0	170.0																														
3.5	170.0	170.0	117.6																												
4.0	170.0	170.0	111.1	157.0	139.0	139.0	116.6	82.5	131.0	119.4	85.5																				
4.5	170.0	170.0	105.3	157.0	139.0	139.0	111.4	77.5	131.0	114.6	80.2																				
5.0	170.0	170.0	100.1	157.0	139.0	139.0	106.6	73.0	131.0	110.2	75.5	109.8	109.4	100.9	67.9																
6.0	157.0	156.8	91.1	156.4	139.0	133.7	97.9	65.5	131.0	102.4	67.6	109.8	108.1	100.9	60.7	75.0	62.7														
7.0	139.2	139.0	83.7	138.5	134.4	121.4	88.8	59.3	129.5	94.9	61.1	103.9	101.6	98.7	54.8	75.0	57.2	63.4	62.7	60.3	51.3										
8.0	124.1	123.9	77.5	123.3	123.9	111.2	81.3	54.3	119.8	87.6	55.8	92.9	93.4	91.9	49.9	75.0	52.6	63.4	62.7	60.3	51.3	48.3	47.8	43.5							
9.0	110.9	110.7	72.2	110.1	110.7	102.6	74.9	50.0	110.9	81.4	51.3	83.9	84.3	86.0	45.8	75.0	48.6	63.4	62.7	60.1	50.0	48.3	47.8	43.5	40.0						
10.0	100.0	99.8	67.6	99.2	99.8	94.7	69.5	46.3	100.0	76.1	47.4	76.3	76.8	80.8	42.3	73.7	45.2	63.4	60.3	56.6	46.7	48.3	47.8	43.5	40.0	30.7					
11.0	90.8	90.6	63.6	90.0	90.6	87.7	64.8	43.2	90.8	71.4	44.1	69.9	70.4	76.2	39.3	67.5	42.2	61.1	57.2	53.4	43.9	48.3	47.8	43.5	40.0	30.7					
12.0	83.0	82.8	60.2	82.2	82.8	81.7	60.7	40.4	83.0	67.2	41.2	64.4	64.9	72.1	36.6	62.2	39.6	57.6	54.5	50.6	41.4	48.3	47.8	42.8	40.0	30.7					
14.0		70.2	54.5	69.6	70.2	71.0	53.9	35.8	70.4	60.2	36.4	55.5	56.0	65.1	32.2	53.6	35.1	51.3	49.7	45.7	37.0	45.7	45.8	38.6	39.7	30.7					
16.0		59.3	50.2	58.4	59.2	60.2	48.5	32.2	59.4	54.6	32.6	48.5	49.0	59.5	28.7	46.9	31.6	44.8	45.1	41.7	33.5	41.3	41.5	35.2	36.3	30.7					
18.0		41.6	43.1	49.1	49.9	50.8	44.2	29.2	50.0	50.0	29.5	42.9	43.4	51.2	25.9	41.5	28.7	39.5	39.9	38.3	29.8	37.7	38.0	32.3	33.5	28.8					
20.0				42.0	42.8	43.8	40.5	26.3	42.9	44.9	26.6	38.3	38.8	44.0	23.6	37.1	26.2	35.3	35.6	35.5	26.7	34.1	34.5	29.8	31.1	26.1					
22.0				36.6	37.3	38.3	36.8	24.0	37.3	39.3	24.1	34.5	35.0	38.4	21.6	33.4	24.2	31.7	32.1	32.5	24.1	30.7	31.1	27.3	29.0	24.0					
24.0									32.9	34.8	22.1	31.3	31.8	33.9	19.9	30.3	22.4	28.7	29.1	29.5	21.9	27.9	28.2	24.9	27.1	22.1					
26.0									29.2	31.1	20.3	28.3	28.7	30.2	18.5	27.7	20.7	26.1	26.5	26.9	20.0	25.4	25.7	22.8	24.8	20.5					
28.0									23.5	25.1	18.9	25.2	25.6	27.1	17.3	25.4	19.0	23.9	24.3	24.7	18.4	23.2	23.5	21.0	22.7	19.3					
30.0												22.6	23.1	24.5	16.0	23.4	17.5	21.9	22.3	22.8	17.0	21.3	21.6	19.4	20.9	18.2					
32.0												20.5	20.9	22.3	14.9	21.4	16.2	20.2	20.6	21.1	15.7	19.6	20.0	18.0	19.3	17.3					
34.0																19.5	15.1	18.7	19.1	19.6	14.6	18.1	18.5	16.8	17.9	16.5					
36.0																17.8	14.1	17.4	17.7	18.2	13.6	16.8	17.1	15.7	16.7	15.6					
38.0																15.1	13.3	16.2	16.5	16.9	12.8	15.6	16.0	14.7	15.5	14.6					
40.0																		14.9	15.2	15.6	12.0	14.6	14.9	13.8	14.5	13.7					
42.0																		13.7	14.0	14.4	11.3	13.6	13.9	13.1	13.5	12.9					
44.0																						12.7	13.1	12.3	12.7	12.2					
46.0																						11.9	12.2	11.6	11.9	11.5					
48.0																						10.7	10.9	11.0	11.2	10.7					
50.0																									10.5	10.0					
52.0																									9.9	9.4					
54.0																										8.8					
56.0																										8.2					
58.0																										5.6					
ピン無最大荷重	62.0	65.4	70.3	61.8			60.6	68.2	50.4	60.8	64.3	67.0	53.3		60.9	52.0	52.2	62.1	49.5		53.5	51.3	45.2		43.5	40.0	30.7				
θ(°)	0~80		0~80		0~81				0~84.5				0~84.5				0~84.5				0~84.5			0~84.5	0~84.5						
伸長状態(伸長割合%)																															
伸縮ブーム1	0	0	0	45	45	0	0	0	45	0	0	90	90	45	0	90	0	90	90	90	0	90	90	45	90	100					
伸縮ブーム2	0	45	0	45	0	45	0	0	45	45	0	45	45	45	0	45	45	90	90	45	90	90	90	90	90	100					
伸縮ブーム3	0	0	0	0	45	45	45	0	45	45	45	45	0	45	90	45	90	45	0	45	90	90	45	90	90	100					
伸縮ブーム4	0	0	45	0	0	0	45	90	0	45	90	0	45	45	90	45	90	45	90	90	90	45	90	90	90	100					
標準フック	170t	170t		170t				170t				170t		80t	80t	80t				80t			80t	80t							
フック質量	3200kg	3200kg		3200kg				3200kg				3200kg		1270kg	1270kg	1270kg				1270kg			1270kg	1270kg							
補巻時・標準巻掛本数	18	18	13	16	14	13	8	13	9	11	7	7	6	6	5	5	4	4	3	5	4	4	3	5	4	3					
主巻時・標準巻掛本数	18	14	13	11				8				9				8				7			6	3							
主巻時・最大荷重	170.0	140.3	117.6	113.5				82.5				94.7				85.5		85.0		67.9	65.0	62.7	63.4	62.7	60.3	51.3	48.3	47.8	43.5	40.0	30.7

注)カウンタウエイト 98t、アウトリガ張出幅 8.5m
または、カウンタウエイト 98t、アウトリガ張出幅 8.0m

■E性能

ESPブーム

単位:t

性能ブロック 性能番号	1	3	1	3	5	4	2	1	4	2	1	4	6	2	1	2	1	7	9	8	1	10	11	1	1	12		
性能番号	1	14	2	15	19	16	10	3	17	11	4	18	20	12	5	13	6	21	23	22	7	24	25	8	9	26		
ブーム長さ(m) 作業半径(m)	15.0	20.1		25.1				30.2				35.3				40.4		45.4				50.5			55.6	60.0		
3.0	170.0																											
3.5	170.0	170.0	117.6																									
4.0	170.0	170.0	111.1	157.0	139.0	139.0	116.6	82.5	131.0	119.4	85.5																	
4.5	170.0	170.0	105.3	157.0	139.0	139.0	111.4	77.5	131.0	114.6	80.2																	
5.0	170.0	170.0	100.1	157.0	139.0	139.0	106.6	73.0	131.0	110.2	75.5	109.8	109.4	100.9	67.9													
6.0	153.0	152.8	91.1	152.3	139.0	133.7	97.9	65.5	131.0	102.4	67.6	109.8	108.1	100.9	60.7	75.0	62.7											
7.0	134.2	133.9	83.7	133.4	134.0	121.4	88.8	59.3	129.5	94.9	61.1	103.9	101.6	98.7	54.8	75.0	57.2	63.4	62.7	60.3	51.3							
8.0	118.3	118.1	77.5	117.5	118.1	111.2	81.3	54.3	118.4	87.6	55.8	92.9	93.4	91.9	49.9	75.0	52.6	63.4	62.7	60.3	51.3	48.3	47.8	43.5				
9.0	105.5	105.2	72.2	104.7	105.3	102.6	74.9	50.0	105.5	81.4	51.3	83.9	84.3	86.0	45.8	75.0	48.6	63.4	62.7	60.1	50.0	48.3	47.8	43.5	40.0			
10.0	94.9	94.6	67.6	94.0	94.6	94.7	69.5	46.3	94.9	76.1	47.4	76.3	76.8	80.8	42.3	73.7	45.2	63.4	60.3	56.6	46.7	48.3	47.8	43.5	40.0	30.7		
11.0	86.0	85.7	63.6	85.1	85.7	86.5	64.8	43.2	85.9	71.4	44.1	69.9	70.4	76.2	39.3	67.5	42.2	61.1	57.2	53.4	43.9	48.3	47.8	43.5	40.0	30.7		
12.0	77.2	76.8	60.2	75.9	76.8	77.9	60.7	40.4	77.1	67.2	41.2	64.4	64.9	72.1	36.6	62.2	39.6	57.6	54.5	50.6	41.4	48.3	47.8	42.8	40.0	30.7		
14.0		60.8	54.5	59.9	60.7	61.8	53.9	35.8	61.0	60.2	36.4	55.5	56.0	62.3	32.2	53.6	35.1	51.3	49.7	45.7	37.0	45.7	45.8	38.6	39.7	30.7		
16.0		49.8	50.2	48.9	49.7	50.7	48.5	32.2	49.9	52.0	32.6	48.5	49.0	51.1	28.7	46.9	31.6	44.8	45.1	41.7	33.5	41.3	41.5	35.2	36.3	30.7		
18.0		41.6	43.1	40.8	41.6	42.6	44.1	29.2	41.8	43.8	29.5	41.0	41.4	43.0	25.9	41.5	28.7	39.5	39.9	38.3	29.8	37.7	38.0	32.3	33.5	28.8		
20.0				34.8	35.6	36.5	37.9	26.3	35.7	37.6	26.6	34.8	35.3	36.8	23.6	36.2	26.2	35.3	35.6	35.5	26.7	34.1	34.5	29.8	31.1	26.1		
22.0				30.1	30.9	31.8	33.2	24.0	30.9	32.8	24.1	30.0	30.5	31.9	21.6	31.3	24.2	31.4	31.8	32.2	24.1	30.7	31.1	27.3	29.0	24.0		
24.0									27.0	28.9	22.1	26.1	26.6	28.0	19.9	27.4	22.4	27.5	27.8	28.2	21.9	27.9	28.2	24.9	27.1	22.1		
26.0									23.9	25.8	20.3	23.0	23.4	24.8	18.5	24.2	20.7	24.2	24.6	25.0	20.0	24.7	25.0	22.8	24.8	20.5		
28.0									21.4	23.3	18.9	20.3	20.7	22.2	17.3	21.5	19.0	21.5	21.9	22.3	18.4	22.0	22.3	21.0	22.7	19.3		
30.0												18.1	18.5	19.9	16.0	19.2	17.5	19.2	19.5	19.9	17.0	19.7	20.0	19.4	20.3	18.2		
32.0												16.2	16.6	18.1	14.9	17.2	16.2	17.2	17.6	18.0	15.7	17.7	18.0	18.0	18.3	17.3		
34.0																15.5	15.1	15.5	15.8	16.2	14.6	15.9	16.2	16.8	16.6	16.5		
36.0																14.0	14.1	14.0	14.3	14.7	13.6	14.4	14.7	15.6	15.0	15.1		
38.0																12.8	13.3	12.7	13.0	13.4	12.8	13.0	13.3	14.3	13.7	13.8		
40.0																		11.5	11.8	12.2	12.0	11.8	12.1	13.1	12.4	12.5		
42.0																		10.5	10.8	11.2	11.3	10.8	11.1	12.0	11.4	11.5		
44.0																						9.8	10.1	11.1	10.4	10.5		
46.0																						8.9	9.2	10.2	9.5	9.6		
48.0																						8.0	8.4	9.5	8.7	8.7		
50.0																									7.9	7.9		
52.0																									7.2	7.2		
54.0																										6.5		
56.0																										5.9		
58.0																										5.4		
ピン無最大荷重	62.0	65.4	70.3	61.8			60.6	68.2	50.4	60.8	64.3	67.0	53.3		60.9	52.0	52.2	62.1	49.5		53.5	51.3	45.2		43.5	40.0	30.7	
θ(°)	0~80		0~80		0~81				0~84.5				0~84.5				0~84.5				0~84.5				0~84.5		0~84.5	

伸長状態(伸長割合%)

伸縮ブーム1	0	0	0	45	45	0	0	0	45	0	0	90	90	45	0	90	0	90	90	90	0	90	90	45	90	100		
伸縮ブーム2	0	45	0	45	0	45	0	0	45	45	0	45	45	45	0	45	45	90	90	45	90	90	90	90	90	100		
伸縮ブーム3	0	0	0	0	45	45	45	0	45	45	45	45	0	45	90	45	90	45	0	45	90	90	45	90	90	100		
伸縮ブーム4	0	0	45	0	0	0	45	90	0	45	90	0	45	45	90	45	90	45	90	90	90	45	90	90	90	100		
標準フック	170t	170t		170t				170t				170t		80t	80t		80t				80t		80t	80t				
フック質量	3200kg	3200kg		3200kg				3200kg				3200kg		1270kg	1270kg		1270kg				1270kg		1270kg	1270kg				
補巻時・標準巻掛本数	18	18	13	16	14		13	8	13		9	11		7	7	6	6		5		5	4	4	3				
主巻時・標準巻掛本数	18	14	13	11			8		9			8		7		6			5		5	4	4	3				
主巻時・最大荷重	170.0	140.3	117.6	113.5				82.5		94.7		85.5		85.0		67.9		65.0	62.7	63.4	62.7	60.3	51.3	48.3	47.8	43.5	40.0	30.7

注)カウンタウエイト 78t、アウトリガ張出幅 8.5m
または、カウンタウエイト 78t、アウトリガ張出幅 8.0m

■F性能

ESPブーム

単位: t

性能ブロック 性能番号	1	3	1	3	5	4	2	1	4	2	1	4	6	2	1	2	1	7	9	8	1	10	11	1	1	12		
ブーム長さ(m) 作業半径(m)	15.0	20.1		25.1				30.2			35.3			40.4		45.4				50.5			55.6	60.0				
3.0	170.0																											
3.5	170.0	170.0	117.6																									
4.0	170.0	170.0	111.1	157.0	139.0	139.0	116.6	82.5																				
4.5	170.0	170.0	105.3	157.0	139.0	139.0	111.4	77.5																				
5.0	167.9	167.7	100.1	157.0	139.0	139.0	106.6	73.0	131.0	110.2	75.5																	
6.0	145.2	144.9	91.1	144.4	139.0	133.7	97.9	65.5	131.0	102.4	67.6	109.8	108.1	100.9	60.7	75.0	62.7											
7.0	126.9	126.6	83.7	126.1	126.7	121.4	88.8	59.3	126.9	94.9	61.1	103.9	101.6	98.7	54.8	75.0	57.2	63.4	62.7	60.3	51.3							
8.0	111.6	111.3	77.5	110.8	111.4	111.2	81.3	54.3	111.6	87.6	55.8	92.9	93.4	91.9	49.9	75.0	52.6	63.4	62.7	60.3	51.3	48.3	47.8	43.5				
9.0	99.2	99.0	72.2	98.4	99.0	99.8	74.9	50.0	99.2	81.4	51.3	83.9	84.3	86.0	45.8	75.0	48.6	63.4	62.7	60.1	50.0	48.3	47.8	43.5	40.0			
10.0	84.9	84.5	67.6	83.6	84.5	85.8	69.5	46.3	84.9	76.1	47.4	76.3	76.8	80.8	42.3	73.7	45.2	63.4	60.3	56.6	46.7	48.3	47.8	43.5	40.0	30.7		
11.0	72.8	72.4	63.6	71.5	72.4	73.5	64.8	43.2	72.7	71.4	44.1	69.9	70.4	74.2	39.3	67.5	42.2	61.1	57.2	53.4	43.9	48.3	47.8	43.5	40.0	30.7		
12.0	63.4	63.0	60.2	62.1	63.0	64.1	60.7	40.4	63.3	65.6	41.2	62.4	62.9	64.7	36.6	62.2	39.6	57.6	54.5	50.6	41.4	48.3	47.8	42.8	40.0	30.7		
14.0		49.5	51.4	48.6	49.4	50.5	52.0	35.8	49.7	51.9	36.4	48.8	49.3	51.0	32.2	50.4	35.1	50.6	49.7	45.7	37.0	45.7	45.8	38.6	39.7	30.7		
16.0		40.3	42.1	39.3	40.2	41.2	42.6	32.2	40.4	42.5	32.6	39.5	40.0	41.6	28.7	41.0	31.6	41.2	41.5	41.7	33.5	41.3	41.5	35.2	36.3	30.7		
18.0		33.7	35.5	32.6	33.4	34.4	35.8	29.2	33.6	35.6	29.5	32.7	33.2	34.8	25.9	34.2	28.7	34.3	34.6	35.1	29.8	34.8	35.1	32.3	33.5	28.8		
20.0				27.5	28.3	29.3	30.7	26.3	28.4	30.4	26.6	27.6	28.0	29.6	23.6	28.9	26.2	29.1	29.4	29.8	26.7	29.6	29.9	29.8	30.3	26.1		
22.0				23.5	24.3	25.3	26.7	24.0	24.3	26.3	24.1	23.4	23.9	25.4	21.6	24.8	24.2	24.9	25.2	25.7	24.1	25.4	25.7	26.8	26.1	24.0		
24.0									21.0	22.9	22.1	20.1	20.5	22.0	19.9	21.4	22.4	21.5	21.8	22.2	21.9	22.0	22.3	23.3	22.7	22.1		
26.0									18.3	20.2	20.3	17.4	17.8	19.3	18.5	18.6	20.7	18.7	19.0	19.4	20.0	19.2	19.5	20.5	19.9	20.0		
28.0									16.2	18.1	18.9	15.1	15.5	17.0	17.3	16.3	18.9	16.4	16.7	17.1	18.4	16.8	17.1	18.1	17.5	17.6		
30.0												13.2	13.7	15.1	16.0	14.3	17.0	14.4	14.7	15.1	16.5	14.8	15.1	16.1	15.5	15.6		
32.0												11.7	12.1	13.5	14.9	12.7	15.3	12.7	13.0	13.4	14.8	13.2	13.4	14.4	13.8	13.9		
34.0																11.3	13.8	11.3	11.6	12.0	13.4	11.7	12.0	13.0	12.3	12.5		
36.0																10.0	12.6	10.0	10.3	10.7	12.1	10.4	10.7	11.7	11.0	11.2		
38.0																8.8	11.6	8.7	9.1	9.6	11.0	9.2	9.6	10.5	9.9	10.0		
40.0																		7.7	8.1	8.6	10.0	8.1	8.5	9.6	8.9	9.0		
42.0																		6.7	7.1	7.6	9.2	7.1	7.5	8.7	7.9	8.0		
44.0																						6.3	6.6	7.8	7.0	7.1		
46.0																						5.5	5.8	7.0	6.2	6.2		
48.0																						4.8	5.2	6.4	5.4	5.5		
50.0																									4.8	4.8		
52.0																									4.2	4.2		
54.0																										3.7		
56.0																										3.2		
58.0																										2.7		
ピン無最大荷重	62.0	65.4	70.3	61.8			60.6	68.2	50.4	60.8	64.3	67.0	53.3		60.9	52.0	52.2	62.1	49.5		53.5	51.3	45.2		43.5	40.0	30.7	
θ(°)	0~76	0~79		0~81				0~81			0~83			0~83		0~84.5				0~84		0~84.5			0~84.5		0~84.5	
伸長状態(伸長割合%)																												
伸縮ブーム1	0	0	0	45	45	0	0	0	45	0	0	90	90	45	0	90	0	90	90	90	0	90	90	45	90	100		
伸縮ブーム2	0	45	0	45	0	45	0	0	45	45	0	45	45	45	0	45	45	90	90	45	90	90	90	90	90	100		
伸縮ブーム3	0	0	0	0	45	45	45	0	45	45	45	45	0	45	90	45	90	45	0	45	90	90	45	90	90	100		
伸縮ブーム4	0	0	45	0	0	0	45	90	0	45	90	0	45	45	90	45	90	45	90	90	90	45	90	90	90	100		
標準フック	170t	170t		170t				170t			170t			80t	80t		80t				80t		80t	80t	80t	80t	80t	
フック質量	3200kg	3200kg		3200kg				3200kg			3200kg			1270kg	1270kg		1270kg				1270kg		1270kg	1270kg	1270kg	1270kg	1270kg	
補巻時・標準巻掛本数	18	18	13	16	14		13	8	13	11	8	11		6	7	6	6		5		5	4	4	4	3			
主巻時・標準巻掛本数	18	14	13	11				8	9	8	8		6	6		6				5	5	4	4	3				
主巻時・最大荷重	170.0	140.3	117.6	113.5				82.5	94.7	75.5	85.0			60.7	65.0	62.7	63.4	62.7	60.3	51.3	48.3	47.8	43.5	40.0	30.7			

注)カウンタウエイト 78t、アウトリガ張出幅 6.8m

または、カウンタウエイト 58t、アウトリガ張出幅 8.5m

または、カウンタウエイト 58t、アウトリガ張出幅 8.0m

■G性能

ESPブーム

単位:t

性能ブロック 性能番号	1	3	1	3	5	4	2	1	4	2	1	4	6	2	1	2	1	7	9	8	1	10	11	1	1	12		
性能番号	1	14	2	15	19	16	10	3	17	11	4	18	20	12	5	13	6	21	23	22	7	24	25	8	9	26		
ブーム長さ(m) 作業半径(m)	15.0	20.1		25.1				30.2				35.3				40.4		45.4				50.5			55.6	60.0		
3.0	170.0																											
3.5	170.0	170.0	117.6																									
4.0	170.0	170.0	111.1	157.0	139.0	139.0	116.6	82.5	131.0	119.4	85.5																	
4.5	170.0	170.0	105.3	157.0	139.0	139.0	111.4	77.5	131.0	114.6	80.2																	
5.0	161.8	161.6	100.1	157.0	139.0	139.0	106.6	73.0	131.0	110.2	75.5	109.8	109.4	100.9	67.9													
6.0	138.6	138.4	91.1	137.8	138.4	133.7	97.9	65.5	131.0	102.4	67.6	109.8	108.1	100.9	60.7	75.0	62.7											
7.0	119.8	119.5	83.7	119.0	119.6	120.3	88.8	59.3	119.8	94.9	61.1	103.9	101.6	98.7	54.8	75.0	57.2	63.4	62.7	60.3	51.3							
8.0	105.0	104.7	77.5	104.1	104.7	105.5	81.3	54.3	105.0	87.6	55.8	92.9	93.4	91.9	49.9	75.0	52.6	63.4	62.7	60.3	51.3	48.3	47.8	43.5				
9.0	89.7	89.3	72.2	88.3	89.3	90.6	74.9	50.0	89.7	81.4	51.3	83.9	84.3	86.0	45.8	75.0	48.6	63.4	62.7	60.1	50.0	48.3	47.8	43.5	40.0			
10.0	74.6	74.2	67.6	73.3	74.3	75.5	69.5	46.3	74.6	76.1	47.4	73.6	74.2	76.1	42.3	73.7	45.2	63.4	60.3	56.6	46.7	48.3	47.8	43.5	40.0	30.7		
11.0	63.5	63.1	63.6	62.2	63.1	64.3	64.8	43.2	63.5	65.8	44.1	62.5	63.1	64.9	39.3	64.3	42.2	61.1	57.2	53.4	43.9	48.3	47.8	43.5	40.0	30.7		
12.0	55.0	54.6	56.6	53.7	54.6	55.7	57.3	40.4	54.9	57.2	41.2	54.0	54.5	56.3	36.6	55.7	39.6	55.9	54.5	50.6	41.4	48.3	47.8	42.8	40.0	30.7		
14.0		42.5	44.4	41.6	42.4	43.5	45.0	35.8	42.7	44.8	36.4	41.8	42.3	44.0	32.2	43.4	35.1	43.5	43.9	44.4	37.0	44.1	44.5	38.6	39.7	30.7		
16.0		34.2	36.1	33.3	34.1	35.1	36.6	32.2	34.4	36.4	32.6	33.5	34.0	35.6	28.7	35.0	31.6	35.1	35.5	35.9	33.5	35.7	36.0	35.2	36.3	30.7		
18.0		28.4	30.2	27.4	28.1	29.1	30.5	29.2	28.3	30.3	29.5	27.5	27.9	29.5	25.9	28.9	28.7	29.0	29.4	29.8	29.8	29.5	29.9	30.9	30.3	28.8		
20.0				22.9	23.6	24.6	26.0	26.2	23.8	25.7	26.6	22.9	23.4	24.9	23.6	24.3	26.2	24.4	24.7	25.1	26.6	24.9	25.2	26.2	25.6	25.8		
22.0				19.4	20.2	21.1	22.5	22.7	20.2	22.1	23.2	19.4	19.8	21.3	21.6	20.6	23.3	20.7	21.1	21.5	22.9	21.2	21.5	22.6	22.0	22.1		
24.0									17.4	19.2	20.4	16.5	16.9	18.4	19.9	17.7	20.4	17.8	18.2	18.6	20.0	18.3	18.6	19.6	19.0	19.2		
26.0									15.0	16.9	18.0	14.1	14.5	16.0	17.8	15.3	18.0	15.4	15.7	16.1	17.5	15.9	16.2	17.2	16.6	16.7		
28.0									13.2	15.1	16.2	12.1	12.5	14.0	15.8	13.3	15.9	13.3	13.7	14.1	15.5	13.8	14.1	15.1	14.5	14.6		
30.0												10.3	10.9	12.3	14.1	11.5	14.2	11.6	11.9	12.3	13.7	12.1	12.3	13.3	12.7	12.9		
32.0												8.8	9.3	11.0	12.8	10.1	12.7	10.1	10.5	10.8	12.2	10.6	10.9	11.8	11.2	11.3		
34.0																8.7	11.4	8.7	9.1	9.6	10.9	9.2	9.6	10.5	9.9	10.0		
36.0																7.5	10.3	7.5	7.9	8.4	9.8	8.0	8.3	9.4	8.8	8.9		
38.0																6.5	9.4	6.4	6.8	7.3	8.9	6.9	7.2	8.4	7.6	7.8		
40.0																		5.4	5.8	6.3	8.0	5.9	6.2	7.5	6.6	6.7		
42.0																		4.6	5.0	5.5	7.2	5.0	5.4	6.6	5.7	5.8		
44.0																						4.2	4.6	5.8	5.0	5.0		
46.0																						3.6	3.9	5.1	4.2	4.3		
48.0																						3.0	3.3	4.5	3.6	3.7		
50.0																									3.0	3.1		
52.0																									2.5	2.5		
ピン無最大荷重	62.0	65.4	70.3	61.8				60.6	68.2	50.4	60.8	64.3	67.0	53.3		60.9	52.0	52.2	62.1	49.5		53.5	51.3	45.2		43.5	40.0	30.7
θ(°)	0~80	0~80		0~81				0~84.5				0~84.5				0~84.5		0~84.5				0~84.5			0~84.5	0~84.5		
伸長状態(伸長割合%)																												
伸縮ブーム1	0	0	0	45	45	0	0	0	45	0	0	90	90	45	0	90	0	90	90	90	0	90	90	45	90	100		
伸縮ブーム2	0	45	0	45	0	45	0	0	45	45	0	45	45	45	0	45	45	90	90	45	90	90	90	90	90	100		
伸縮ブーム3	0	0	0	0	45	45	45	0	45	45	45	45	0	45	90	45	90	45	0	45	90	90	45	90	90	100		
伸縮ブーム4	0	0	45	0	0	0	45	90	0	45	90	0	45	45	90	45	90	45	90	90	90	45	90	90	90	100		
標準フック	170t	170t		170t				170t				170t		80t	80t		80t				80t			80t	80t			
フック質量	3200kg	3200kg		3200kg				3200kg				3200kg		1270kg	1270kg		1270kg				1270kg			1270kg	1270kg			
補巻時・標準巻掛本数	18	18	13	16	14	13	8	13	9	11	7	7	6	6			5	5	5	4	4	3						
主巻時・標準巻掛本数	18	14	13	11				8	9		8		7	6		6			5	5	4	4	3					
主巻時・最大荷重	170.0	140.3	117.6	113.5				82.5	94.7		85.5	85.0		67.9	65.0	62.7	63.4	62.7	60.3	51.3	48.3	47.8	43.5	40.0	30.7			

注)カウンタウエイト 58t、アウトリガ張出幅 6.8m
 または、カウンタウエイト 47t、アウトリガ張出幅 8.5m
 または、カウンタウエイト 47t、アウトリガ張出幅 8.0m

■H性能

ESPブーム

単位:t

性能ブロック 性能番号	1	3	1	3	5	4	2	1	4	2	1	4	6	2	1	2	1	7	9	8	1	10	11	1	1	12	
ブーム長さ(m) 作業半径(m)	15.0	20.1		25.1				30.2				35.3				40.4		45.4				50.5			55.6	60.0	
3.0	170.0																										
3.5	170.0	170.0	117.6																								
4.0	170.0	170.0	111.1	157.0	139.0	139.0	116.6	82.5	131.0	119.4	85.5																
4.5	170.0	170.0	105.3	157.0	139.0	139.0	111.4	77.5	131.0	114.6	80.2																
5.0	158.3	158.0	100.1	157.0	139.0	139.0	106.6	73.0	131.0	110.2	75.5	109.8	109.4	100.9	67.9												
6.0	134.2	133.9	91.1	133.4	133.9	133.7	97.9	65.5	131.0	102.4	67.6	109.8	108.1	100.9	60.7	75.0	62.7										
7.0	115.6	115.4	83.7	114.8	115.4	116.2	88.8	59.3	115.7	94.9	61.1	103.9	101.6	98.7	54.8	75.0	57.2	63.4	62.7	60.3	51.3						
8.0	96.7	96.3	77.5	95.2	96.4	97.8	81.3	54.3	96.8	87.6	55.8	92.9	93.4	91.9	49.9	75.0	52.6	63.4	62.7	60.3	51.3	48.3	47.8	43.5			
9.0	77.7	77.3	72.2	76.3	77.3	78.6	74.9	50.0	77.7	80.4	51.3	76.7	77.3	79.4	45.8	75.0	48.6	63.4	62.7	60.1	50.0	48.3	47.8	43.5	40.0		
10.0	64.4	64.0	66.2	63.1	64.1	65.3	67.0	46.3	64.4	66.9	47.4	63.4	64.0	65.9	42.3	65.3	45.2	63.4	60.3	56.6	46.7	48.3	47.8	43.5	40.0	30.7	
11.0	54.6	54.3	56.3	53.4	54.3	55.4	57.1	43.2	54.6	57.0	44.1	53.7	54.2	56.1	39.3	55.4	42.2	55.6	56.0	53.4	43.9	48.3	47.8	43.5	40.0	30.7	
12.0	47.2	46.8	48.8	45.9	46.8	47.9	49.5	40.4	47.1	49.4	41.2	46.2	46.7	48.5	36.6	47.9	39.6	48.0	48.4	48.9	41.4	48.3	47.8	42.8	40.0	30.7	
14.0		36.1	38.0	35.2	36.1	37.1	38.6	35.8	36.3	38.5	36.4	35.5	36.0	37.6	32.2	37.0	35.1	37.2	37.6	38.0	37.0	37.8	38.1	38.6	38.6	30.7	
16.0		28.9	30.7	28.0	28.8	29.8	31.2	31.5	29.0	31.1	32.3	28.2	28.6	30.2	28.7	29.6	31.6	29.8	30.1	30.6	32.1	30.3	30.7	31.8	31.1	30.7	
18.0		23.8	25.6	22.7	23.5	24.5	25.9	26.1	23.7	25.7	26.9	22.9	23.3	24.9	25.9	24.3	27.1	24.4	24.8	25.2	26.7	24.9	25.2	26.3	25.7	25.9	
20.0				18.8	19.6	20.6	21.9	22.2	19.7	21.6	22.8	18.9	19.3	20.8	22.7	20.2	23.0	20.3	20.7	21.1	22.5	20.8	21.1	22.2	21.6	21.7	
22.0				15.8	16.6	17.5	18.9	19.1	16.6	18.5	19.6	15.7	16.2	17.6	19.5	17.0	19.7	17.1	17.5	17.9	19.3	17.6	17.9	18.9	18.3	18.5	
24.0									14.1	16.0	17.1	13.2	13.7	15.1	16.9	14.5	17.1	14.6	14.9	15.3	16.7	15.0	15.3	16.3	15.7	15.9	
26.0									12.1	14.0	15.1	11.2	11.6	13.0	14.8	12.4	15.0	12.5	12.8	13.2	14.6	12.9	13.2	14.2	13.6	13.7	
28.0									10.5	12.4	13.5	9.2	9.8	11.3	13.1	10.6	13.2	10.7	11.0	11.4	12.8	11.1	11.4	12.4	11.8	11.9	
30.0												7.7	8.2	9.9	11.7	9.0	11.7	9.1	9.5	9.9	11.3	9.6	9.9	10.9	10.3	10.4	
32.0												6.3	6.9	8.7	10.5	7.6	10.4	7.6	8.0	8.5	10.0	8.2	8.5	9.6	9.0	9.1	
34.0																6.4	9.3	6.4	6.8	7.3	8.9	6.9	7.3	8.5	7.7	7.8	
36.0																5.3	8.4	5.3	5.7	6.2	7.9	5.8	6.2	7.4	6.6	6.7	
38.0																4.5	7.6	4.4	4.8	5.3	6.9	4.9	5.2	6.4	5.6	5.7	
40.0																		3.5	3.9	4.4	6.1	4.0	4.4	5.5	4.7	4.9	
42.0																		2.8	3.2	3.7	5.4	3.2	3.6	4.8	4.0	4.1	
44.0																						2.6	2.9	4.1	3.3	3.4	
46.0																							2.3	3.5	2.7	2.7	
48.0																								3.0			
ピン無最大荷重	62.0	65.4	70.3	61.8			60.6	68.2	50.4	60.8	64.3	67.0	53.3		60.9	52.0	52.2	62.1	49.5		53.5	51.3	45.2		43.5	40.0	30.7
θ(°)	0~80		0~80		0~81				0~84.5				0~84.5				0~84.5		0~84.5				0~84.5			0~84.5	0~84.5
伸長状態(伸長割合%)																											
伸縮ブーム1	0	0	0	45	45	0	0	0	45	0	0	90	90	45	0	90	0	90	90	90	0	90	90	45	90	100	
伸縮ブーム2	0	45	0	45	0	45	0	0	45	45	0	45	45	45	0	45	45	90	90	45	90	90	90	90	90	100	
伸縮ブーム3	0	0	0	0	45	45	45	0	45	45	45	45	0	45	90	45	90	45	0	45	90	90	45	90	90	100	
伸縮ブーム4	0	0	45	0	0	0	45	90	0	45	90	0	45	45	90	45	90	45	90	90	90	45	90	90	90	100	
標準フック	170t	170t		170t				170t				170t		80t	80t		80t				80t			80t	80t		
フック質量	3200kg	3200kg		3200kg				3200kg				3200kg		1270kg	1270kg		1270kg				1270kg			1270kg	1270kg		
補巻時・標準巻掛本数	18	18	13	16	14	13	8	13	9	11	7	7	6	6	6	5	5	5	5	5	4	4	4	4	3		
主巻時・標準巻掛本数	18	14	13	11			8	9		8	7	6		6		5	5	5	5	4	4	4	4	3			
主巻時・最大荷重	170.0	140.3	117.6	113.5			82.5	94.7		85.5	85.0		67.9	65.0	62.7	63.4	62.7	60.3	51.3	48.3	47.8	43.5	40.0	30.7			

注)カウンタウエイト 47t、アウトリガ張出幅 6.8m

■I性能

ESPブーム

単位:t

性能ブロック 性能番号	1	3	1	3	5	4	2	1	4	2	1	4	6	2	1	2	1	7	9	8	1	10	11	1	1	12	
性能番号	1	14	2	15	19	16	10	3	17	11	4	18	20	12	5	13	6	21	23	22	7	24	25	8	9	26	
ブーム長さ(m) 作業半径(m)	15.0	20.1		25.1				30.2				35.3				40.4		45.4				50.5			55.6	60.0	
3.0	170.0																										
3.5	170.0	170.0	117.6																								
4.0	170.0	170.0	111.1	157.0	139.0	139.0	116.6	82.5	131.0	119.4	85.5																
4.5	158.9	158.7	105.3	157.0	139.0	139.0	111.4	77.5	131.0	114.6	80.2																
5.0	145.6	145.3	100.1	144.8	139.0	139.0	106.6	73.0	131.0	110.2	75.5	109.8	109.4	100.9	67.9												
6.0	122.6	122.4	91.1	121.8	122.4	123.2	97.9	65.5	122.7	102.4	67.6	109.8	108.1	100.9	60.7	75.0	62.7										
7.0	92.6	92.2	83.7	91.1	92.2	93.6	88.8	59.3	92.7	94.9	61.1	91.6	92.2	94.4	54.8	75.0	57.2	63.4	62.7	60.3	51.3						
8.0	73.0	72.6	74.8	71.7	72.7	73.9	75.7	54.3	73.1	75.6	55.8	72.1	72.7	74.6	49.9	74.0	52.6	63.4	62.7	60.3	51.3	48.3	47.8	43.5			
9.0	59.7	59.4	61.4	58.5	59.4	60.6	62.2	50.0	59.8	62.1	51.3	58.8	59.4	61.2	45.8	60.6	48.6	60.8	61.2	60.1	50.0	48.3	47.8	43.5	40.0		
10.0	50.1	49.8	51.8	48.9	49.8	50.9	52.5	46.3	50.1	52.4	47.4	49.2	49.7	51.5	42.3	50.9	45.2	51.1	51.5	52.0	46.7	48.3	47.8	43.5	40.0	30.7	
11.0	42.9	42.5	44.4	41.7	42.5	43.6	45.1	43.2	42.8	45.0	44.1	42.0	42.5	44.2	39.3	43.6	42.2	43.8	44.1	44.6	43.9	44.4	44.7	43.5	40.0	30.7	
12.0	37.2	36.8	38.7	36.0	36.8	37.9	39.4	39.6	37.1	39.2	40.5	36.3	36.8	38.4	36.6	37.8	39.6	38.0	38.4	38.8	40.4	38.6	38.9	40.1	39.4	30.7	
14.0		28.5	30.3	27.7	28.5	29.5	30.9	31.1	28.8	30.8	32.0	27.9	28.4	30.0	31.9	29.4	32.3	29.5	29.9	30.3	31.9	30.1	30.4	31.5	30.9	30.7	
16.0		22.8	24.6	21.9	22.7	23.7	25.1	25.3	22.9	24.9	26.0	22.1	22.6	24.1	26.0	23.5	26.3	23.7	24.0	24.4	25.9	24.2	24.5	25.5	24.9	25.1	
18.0		18.8	20.5	17.7	18.5	19.4	20.8	21.0	18.6	20.6	21.7	17.8	18.3	19.8	21.6	19.2	21.9	19.3	19.6	20.1	21.5	19.8	20.1	21.1	20.5	20.7	
20.0				14.4	15.2	16.2	17.5	17.7	15.3	17.2	18.3	14.4	14.9	16.4	18.3	15.8	18.5	15.9	16.3	16.7	18.1	16.5	16.8	17.8	17.2	17.3	
22.0				11.8	12.6	13.5	14.9	15.2	12.6	14.5	15.7	11.7	12.1	13.7	15.6	13.0	15.8	13.1	13.5	13.9	15.4	13.6	13.9	15.0	14.4	14.5	
24.0									10.4	12.3	13.5	9.4	9.9	11.4	13.3	10.8	13.5	10.9	11.2	11.6	13.1	11.4	11.7	12.7	12.1	12.2	
26.0									8.5	10.6	11.7	7.4	7.9	9.6	11.5	8.9	11.6	9.0	9.4	9.8	11.2	9.5	9.8	10.8	10.2	10.4	
28.0									7.0	9.3	10.4	5.7	6.3	8.1	10.0	7.2	10.1	7.3	7.7	8.2	9.7	7.9	8.2	9.3	8.7	8.8	
30.0												4.4	4.9	6.7	8.8	5.7	8.8	5.8	6.2	6.7	8.4	6.4	6.8	8.0	7.2	7.4	
32.0												3.3	3.8	5.6	7.8	4.5	7.7	4.6	5.0	5.5	7.2	5.1	5.5	6.7	6.0	6.1	
34.0																3.5	6.8	3.5	3.9	4.4	6.2	4.0	4.4	5.7	4.9	5.0	
36.0																2.6	5.9	2.6	3.0	3.5	5.2	3.1	3.5	4.7	3.9	4.0	
38.0																	5.1			2.7	4.4	2.3	2.6	3.9	3.1	3.2	
40.0																					3.7			3.1	2.3	2.4	
42.0																					3.1			2.5			
ピン無最大荷重	62.0	65.4	70.3	61.8		60.6	68.2	50.4	60.8	64.3	67.0	53.3		60.9	52.0	52.2	62.1	49.5		53.5	51.3	45.2		43.5	40.0	30.7	
θ(°)	0~80	0~80		0~81				0~83				0~84.5		0~84	0~84.5		0~84.5				0~84.5			0~84.5	48~84.5		
伸長状態(伸長割合%)																											
伸縮ブーム1	0	0	0	45	45	0	0	0	45	0	0	90	90	45	0	90	0	90	90	90	0	90	90	45	90	100	
伸縮ブーム2	0	45	0	45	0	45	0	0	45	45	0	45	45	45	0	45	45	90	90	45	90	90	90	90	90	100	
伸縮ブーム3	0	0	0	0	45	45	45	0	45	45	45	45	0	45	90	45	90	45	0	45	90	90	45	90	90	100	
伸縮ブーム4	0	0	45	0	0	0	45	90	0	45	90	0	45	45	90	45	90	45	90	90	90	45	90	90	90	100	
標準フック	170t	170t		170t				170t				170t		80t	80t		80t				80t			80t	80t		
フック質量	3200kg	3200kg		3200kg				3200kg				3200kg		1270kg	1270kg		1270kg				1270kg			1270kg	1270kg		
補巻時・標準巻掛本数	18	18	13	16	14		13	8	13		9	11		7	7	6	6		5		5		4	4	3		
主巻時・標準巻掛本数	18	14	13	11				8		9		8		7	6		6		5		5		4	4	3		
主巻時・最大荷重	170.0	140.3	117.6	113.5				82.5		94.7		85.5		85.0		67.9	65.0	62.7	63.4	62.7	60.3	51.3	48.3	47.8	43.5	40.0	30.7

注)カウンタウエイト 47t、アウトリガ張出幅 5.5m
 または、カウンタウエイト 25t、アウトリガ張出幅 8.5m
 または、カウンタウエイト 25t、アウトリガ張出幅 8.0m

■J性能

ESPブーム

単位:t

性能ブロック	1	3	1	3	5	4	2	1	4	2	1	4	6	2	1	2	1	7	9	8	1	10	11	1	1	12						
性能番号	1	14	2	15	19	16	10	3	17	11	4	18	20	12	5	13	6	21	23	22	7	24	25	8	9	26						
ブーム長さ(m)	15.0	20.1		25.1				30.2				35.3				40.4		45.4				50.5			55.6	60.0						
作業半径(m)	170.0																															
3.0	170.0																															
3.5	170.0	170.0	117.6																													
4.0	170.0	170.0	111.1	157.0	139.0	139.0	116.6	82.5	131.0	119.4	85.5																					
4.5	163.3	163.1	105.3	157.0	139.0	139.0	111.4	77.5	131.0	114.6	80.2																					
5.0	148.7	148.4	100.1	147.8	139.0	139.0	106.6	73.0	131.0	110.2	75.5	109.8	109.4	100.9	67.9																	
6.0	125.1	124.9	91.1	124.3	124.9	125.7	97.9	65.5	125.2	102.4	67.6	109.8	108.1	100.9	60.7	75.0	62.7															
7.0	90.5	90.0	83.7	88.8	90.1	91.7	88.8	59.3	90.6	93.9	61.1	89.3	90.1	92.6	54.8	75.0	57.2	63.4	62.7	60.3	51.3											
8.0	68.6	68.2	70.7	67.1	68.3	69.7	71.7	54.3	68.7	71.6	55.8	67.6	68.2	70.5	49.9	69.8	52.6	63.4	62.7	60.3	51.3	48.3	47.8	43.5								
9.0	54.6	54.2	56.5	53.2	54.2	55.5	57.4	50.0	54.6	57.3	51.3	53.6	54.2	56.3	45.8	55.6	48.6	55.8	56.3	56.8	50.0	48.3	47.8	43.5	40.0							
10.0	44.8	44.4	46.6	43.5	44.5	45.7	47.4	46.3	44.8	47.3	47.4	43.8	44.4	46.4	42.3	45.7	45.2	45.9	46.3	46.9	46.7	46.6	47.0	43.5	40.0	30.7						
11.0	37.6	37.2	39.3	36.3	37.3	38.4	40.1	40.3	37.6	40.0	41.4	36.7	37.2	39.1	39.3	38.4	41.8	38.6	39.0	39.5	41.3	39.3	39.6	40.9	40.0	30.7						
12.0	32.1	31.8	33.8	30.9	31.8	32.9	34.5	34.7	32.1	34.3	35.7	31.2	31.7	33.4	35.7	32.8	36.1	33.0	33.4	33.9	35.6	33.6	34.0	35.2	34.5	30.7						
14.0		23.9	25.8	23.0	23.9	24.9	26.4	26.7	24.1	26.3	27.5	23.3	23.8	25.4	27.5	24.8	27.9	25.0	25.4	25.8	27.4	25.6	25.9	27.1	26.4	26.6						
16.0		18.6	20.4	17.7	18.5	19.5	21.0	21.2	18.7	20.8	22.0	17.9	18.4	20.0	22.0	19.4	22.3	19.5	19.9	20.3	21.9	20.1	20.4	21.5	20.8	21.0						
18.0		14.9	16.7	13.8	14.7	15.7	17.1	17.3	14.8	16.8	18.0	14.0	14.4	16.0	18.0	15.4	18.2	15.5	15.9	16.3	17.8	16.1	16.4	17.5	16.8	17.0						
20.0				10.9	11.7	12.7	14.1	14.3	11.8	13.8	15.0	10.9	11.4	12.9	14.9	12.3	15.2	12.4	12.8	13.2	14.7	13.0	13.3	14.4	13.7	13.9						
22.0				8.4	9.4	10.4	11.8	12.1	9.4	11.4	12.6	8.4	8.9	10.5	12.5	9.9	12.7	10.0	10.4	10.8	12.3	10.5	10.8	11.9	11.3	11.4						
24.0									7.4	9.5	10.7	6.2	6.8	8.6	10.5	7.8	10.7	7.9	8.4	8.8	10.3	8.6	8.9	9.9	9.3	9.4						
26.0									5.7	8.1	9.2	4.5	5.1	6.9	9.0	6.0	9.1	6.2	6.6	7.1	8.7	6.8	7.1	8.3	7.6	7.8						
28.0									4.4	6.8	8.0	3.1	3.7	5.5	7.7	4.6	7.8	4.7	5.1	5.6	7.3	5.3	5.6	6.9	6.1	6.3						
30.0													2.5	4.3	6.6	3.3	6.6	3.4	3.8	4.3	6.1	4.0	4.4	5.6	4.8	5.0						
32.0														3.4	5.7	2.3	5.6	2.4	2.8	3.3	5.0	2.9	3.3	4.5	3.7	3.9						
34.0																	4.7			2.3	4.1		2.3	3.6	2.8	2.9						
36.0																	3.9				3.3			2.7								
38.0																	3.3				2.6											
ピン無最大荷重	62.0	65.4	70.3	61.8		60.6	68.2	50.4	60.8	64.3	67.0	53.3		60.9	52.0	52.2	62.1	49.5		53.5	51.3	45.2		43.5	40.0	30.7						
θ(°)	0~80		0~80		0~81				0~84.5				0~84.5				0~84.5		41~84.5		0~84.5		49~84.5		45~84.5		0~84.5		51~84.5		56~84.5	
伸縮状態(伸縮割合%)																																
伸縮ブーム1	0	0	0	45	45	0	0	0	45	0	0	90	90	45	0	90	0	90	90	90	0	90	90	45	90	100						
伸縮ブーム2	0	45	0	45	0	45	0	0	45	45	0	45	45	45	0	45	45	90	90	45	90	90	90	90	90	100						
伸縮ブーム3	0	0	0	0	45	45	45	0	45	45	45	45	0	45	90	45	90	45	0	45	90	90	45	90	90	100						
伸縮ブーム4	0	0	45	0	0	0	45	90	0	45	90	0	45	45	90	45	90	45	90	90	90	45	90	90	90	100						
標準フック	170t	170t		170t				170t				170t		80t	80t	80t				80t		80t	80t									
フック質量	3200kg	3200kg		3200kg				3200kg				3200kg		1270kg	1270kg	1270kg				1270kg		1270kg	1270kg									
補巻時・標準巻掛本数	18	18	13	16	14	13	8	13	9	11	7	7	6	6		5	5	5	4	4	3											
主巻時・標準巻掛本数	18	14	13	11				8	9		8	7	6		6		5	5	4	4	3											
主巻時・最大荷重	170.0	140.3	117.6	113.5				82.5	94.7	85.5	85.0		67.9	65.0	62.7	63.4	62.7	60.3	51.3	48.3	47.8	43.5	40.0	30.7								

注)カウンタウエイト 25t、アウトリガ張出幅 6.8m
 または、カウンタウエイト 16.5t、アウトリガ張出幅 8.5m
 または、カウンタウエイト 16.5t、アウトリガ張出幅 8.0m

■K性能

ESPブーム

単位:t

性能ブロック 性能番号	1	3	1	3	5	4	2	1	4	2	1	4	6	2	1	2	1	7	9	8	1	10	11	1	1	12	
性能番号	1	14	2	15	19	16	10	3	17	11	4	18	20	12	5	13	6	21	23	22	7	10	24	25	8	9	26
ブーム長さ(m) 作業半径(m)	15.0	20.1		25.1				30.2				35.3				40.4		45.4				50.5			55.6	60.0	
3.0	170.0																										
3.5	170.0	170.0	117.6																								
4.0	165.4	165.2	111.1	157.0	139.0	139.0	116.6	82.5	131.0	119.4	85.5																
4.5	148.9	148.7	105.3	148.1	139.0	139.0	111.4	77.5	131.0	114.6	80.2																
5.0	131.3	130.7	100.1	129.3	130.8	132.6	106.6	73.0	131.0	110.2	75.5	109.8	109.4	100.9	67.9												
6.0	87.7	87.3	90.0	86.1	87.3	88.9	91.1	65.5	87.9	91.0	67.6	86.6	87.3	89.8	60.7	75.0	62.7										
7.0	64.7	64.3	66.7	63.3	64.3	65.7	67.6	59.3	64.8	67.5	61.1	63.7	64.3	66.5	54.8	65.8	57.2	63.4	62.7	60.3	51.3						
8.0	50.4	50.1	52.3	49.1	50.1	51.4	53.1	53.4	50.5	53.0	54.5	49.5	50.1	52.1	49.9	51.5	52.6	51.6	52.1	52.6	51.3	48.3	47.8	43.5			
9.0	40.7	40.4	42.5	39.5	40.4	41.6	43.3	43.5	40.8	43.2	44.6	39.9	40.4	42.3	44.6	41.7	45.1	41.9	42.3	42.8	44.6	42.5	42.9	43.5	40.0		
10.0	33.8	33.4	35.4	32.6	33.5	34.6	36.2	36.4	33.8	36.0	37.4	32.9	33.4	35.2	37.4	34.6	37.8	34.8	35.2	35.6	37.4	35.4	35.8	37.0	36.3	30.7	
11.0	28.5	28.1	30.1	27.3	28.2	29.2	30.8	31.0	28.5	30.7	31.9	27.6	28.1	29.8	31.9	29.2	32.3	29.4	29.8	30.2	31.9	30.0	30.3	31.5	30.8	30.7	
12.0	24.4	24.0	25.9	23.2	24.0	25.1	26.5	26.8	24.3	26.4	27.7	23.5	23.9	25.6	27.7	25.0	28.0	25.2	25.6	26.0	27.6	25.8	26.1	27.2	26.6	26.8	
14.0		18.0	19.8	17.2	18.0	19.0	20.4	20.6	18.2	20.2	21.4	17.4	17.9	19.4	21.4	18.9	21.7	19.0	19.4	19.8	21.3	19.6	19.9	21.0	20.3	20.5	
16.0		13.9	15.6	13.0	13.8	14.7	16.1	16.3	14.0	15.9	17.1	13.2	13.6	15.1	17.1	14.6	17.4	14.7	15.1	15.5	17.0	15.2	15.5	16.6	16.0	16.2	
18.0		10.8	12.7	9.7	10.5	11.5	13.0	13.2	10.7	12.8	13.9	9.8	10.3	11.9	13.9	11.3	14.1	11.4	11.8	12.2	13.7	12.0	12.3	13.4	12.8	12.9	
20.0				6.9	7.9	9.0	10.5	10.7	8.1	10.2	11.4	7.0	7.6	9.3	11.3	8.7	11.5	8.8	9.2	9.6	11.1	9.3	9.7	10.7	10.1	10.3	
22.0				4.8	5.8	7.0	8.6	8.8	5.9	8.2	9.4	4.8	5.4	7.3	9.3	6.4	9.5	6.6	7.0	7.5	9.1	7.2	7.6	8.7	8.0	8.2	
24.0									4.1	6.6	7.8	3.0	3.6	5.5	7.6	4.6	7.8	4.7	5.2	5.7	7.4	5.3	5.7	7.0	6.2	6.4	
26.0									2.8	5.2	6.5			4.0	6.3	3.1	6.5	3.2	3.7	4.2	6.0	3.8	4.2	5.5	4.7	4.9	
28.0										4.1	5.6				2.8	5.1		5.2		2.4	2.9	4.7		2.9	4.2	3.4	
30.0															4.1		4.2							3.1			
32.0															3.4		3.3										
34.0																	2.5										
ピン無最大荷重	62.0	65.4	70.3	61.8		60.6	68.2	50.4	60.8	64.3	67.0	53.3		60.9	52.0	52.2	62.1	49.5		53.5	51.3	45.2		43.5	40.0	30.7	
θ(°)	0~80	0~80		0~81				0~84.5				41~84.5	0~84.5				46~84.5	0~84.5	52~84.5	49~84.5	0~84.5	58~84.5	55~84.5	52~84.5	59~84.5	65~84.5	
伸長状態(伸長割合%)																											
伸縮ブーム1	0	0	0	45	45	0	0	0	45	0	0	90	90	45	0	90	0	90	90	90	0	90	90	45	90	100	
伸縮ブーム2	0	45	0	45	0	45	0	0	45	45	0	45	45	45	0	45	45	90	90	45	90	90	90	90	90	100	
伸縮ブーム3	0	0	0	0	45	45	45	0	45	45	45	45	0	45	90	45	90	45	0	45	90	90	45	90	90	100	
伸縮ブーム4	0	0	45	0	0	0	45	90	0	45	90	0	45	45	90	45	90	45	90	90	90	45	90	90	90	100	
標準フック	170t	170t		170t				170t				170t		80t	80t		80t				80t			80t	80t		
フック質量	3200kg	3200kg		3200kg				3200kg				3200kg		1270kg	1270kg		1270kg				1270kg			1270kg	1270kg		
補巻時・標準巻掛本数	18	18	13	16	14	13	8		13	9		11	7	7	6		6		5		5	4	4	3			
主巻時・標準巻掛本数	18	14	13		11		8		9			8	7	6			6		5		5	4	4	3			
主巻時・最大荷重	170.0	140.3	117.6	113.5				82.5	94.7		85.5	85.0		67.9	65.0	62.7	63.4	62.7	60.3	51.3	48.3	47.8	43.5	40.0	30.7		

注)カウンタウエイト 25t、アウトリガ張出幅 5.5m
 または、カウンタウエイト 16.5t、アウトリガ張出幅 6.8m
 または、カウンタウエイト 7.5t、アウトリガ張出幅 8.5m
 または、カウンタウエイト 7.5t、アウトリガ張出幅 8.0m

■L性能

ESPブーム

単位:t

性能ブロック	1	3	1	3	5	4	2	1	4	2	1	4	6	2	1	2	1	7	9	8	1	10	11	1	1	12	
性能番号	1	14	2	15	19	16	10	3	17	11	4	18	20	12	5	13	6	21	23	22	7	24	25	8	9	26	
ブーム長さ(m)	15.0	20.1		25.1				30.2				35.3				40.4		45.4				50.5			55.6	60.0	
作業半径(m)	3.0	3.5	4.0	4.5	5.0	6.0	7.0	8.0	9.0	10.0	11.0	12.0	14.0	16.0	18.0	20.0	22.0	24.0	26.0	28.0	30.0	32.0	34.0	36.0	38.0	40.0	
170.0	170.0	170.0	117.6	157.0	139.0	139.0	116.6	82.5	131.0	119.4	85.5																
160.5	160.2	111.1	157.0	139.0	139.0	116.6	82.5	131.0	119.4	85.5																	
144.2	143.8	105.3	142.2	139.0	139.0	111.4	77.5	131.0	114.6	80.2																	
110.1	109.5	100.1	108.1	109.6	111.5	106.6	73.0	110.3	110.2	75.5	108.8	109.4	100.9	67.9													
73.1	72.6	75.4	71.5	72.7	74.2	76.4	65.5	73.2	76.3	67.6	72.0	72.7	75.2	60.7	74.4	62.7											
53.5	53.1	55.5	52.1	53.1	54.5	56.4	56.7	53.6	56.3	58.0	52.5	53.1	55.3	54.8	54.6	57.2	54.9	55.3	55.9	51.3							
41.3	41.0	43.2	40.1	41.1	42.3	44.1	44.3	41.5	44.0	45.5	40.5	41.0	43.0	45.5	42.4	46.0	42.6	43.0	43.6	45.5	43.3	43.7	43.5				
33.1	32.8	34.9	31.9	32.8	34.0	35.7	35.9	33.2	35.6	37.0	32.3	32.8	34.7	37.0	34.1	37.5	34.2	34.7	35.2	37.0	34.9	35.3	36.6	35.8			
27.2	26.9	28.8	26.0	26.9	28.0	29.6	29.8	27.2	29.5	30.8	26.3	26.8	28.6	30.8	28.0	31.3	28.2	28.6	29.1	30.8	28.8	29.2	30.4	29.7	29.9		
22.7	22.4	24.3	21.5	22.4	23.5	25.0	25.2	22.7	24.9	26.2	21.8	22.3	24.0	26.2	23.5	26.6	23.6	24.0	24.5	26.1	24.2	24.6	25.8	25.1	25.3		
19.2	18.9	20.7	18.0	18.9	19.9	21.4	21.6	19.2	21.3	22.5	18.3	18.8	20.5	22.5	19.9	22.9	20.0	20.4	20.9	22.5	20.6	21.0	22.1	21.4	21.6		
	13.8	15.5	12.9	13.7	14.7	16.2	16.4	14.0	16.0	17.2	13.2	13.6	15.2	17.2	14.6	17.5	14.8	15.1	15.6	17.1	15.3	15.6	16.7	16.1	16.3		
	10.2	12.0	9.3	10.1	11.1	12.5	12.7	10.4	12.3	13.5	9.5	10.0	11.5	13.5	11.0	13.8	11.1	11.5	11.9	13.4	11.6	11.9	13.0	12.4	12.6		
	7.5	9.5	6.2	7.2	8.4	9.8	10.1	7.5	9.6	10.8	6.4	7.0	8.8	10.7	8.1	11.0	8.3	8.7	9.1	10.6	8.8	9.1	10.2	9.6	9.8		
			4.0	4.9	6.1	7.8	8.0	5.1	7.5	8.6	4.1	4.6	6.5	8.6	5.7	8.8	5.8	6.3	6.8	8.4	6.5	6.9	8.0	7.4	7.6		
			2.3	3.2	4.4	6.1	6.4	3.3	5.7	7.0		2.8	4.6	6.9	3.8	7.1	3.9	4.4	4.9	6.7	4.6	4.9	6.2	5.4	5.6		
									4.2	5.6			3.1	5.4		5.6			3.4	5.1			4.7				
									3.1	4.4				4.2		4.4				3.8			3.4				
										3.6					3.2		3.3				2.8						
															2.4		2.4										
ピン無最大荷重	62.0	65.4	70.3	61.8			60.6	68.2	50.4	60.8	64.3	67.0	53.3		60.9	52.0	52.2	62.1	49.5		53.5	51.3	43.3	43.7	43.5	35.8	29.9
θ(°)	0~80	0~80		0~81				0~84.5				5~84.5	46~84.5	0~84.5		54~84.5	0~84.5	59~84.5	55~84.5	49~84.5	63~84.5		57~84.5	66~84.5	69~84.5		
伸長状態(伸長割合%)																											
伸縮ブーム1	0	0	0	45	45	0	0	0	45	0	0	90	90	45	0	90	0	90	90	90	0	90	90	45	90	100	
伸縮ブーム2	0	45	0	45	0	45	0	0	45	45	0	45	45	45	0	45	45	90	90	45	90	90	90	90	90	100	
伸縮ブーム3	0	0	0	0	45	45	45	0	45	45	45	45	0	45	90	45	90	45	0	45	90	90	45	90	90	100	
伸縮ブーム4	0	0	45	0	0	0	45	90	0	45	90	0	45	45	90	45	90	45	90	90	90	45	90	90	90	100	
標準フック	170t	170t		170t				170t				170t		80t	80t		80t				80t		80t	80t	80t		
フック質量	3200kg	3200kg		3200kg				3200kg				3200kg		1270kg	1270kg		1270kg				1270kg		1270kg	1270kg	1270kg		
補巻時・標準巻掛本数	18	18	13	16	14		13	8	13		9	11		7	7	6	6		5		4		4	3			
主巻時・標準巻掛本数	18	14	13	11				8		9		8		7	6		6		5		4		4	3			
主巻時・最大荷重	170.0	140.3	117.6	113.5				82.5		94.7		85.5	85.0		67.9	65.0	62.7	54.9	55.3	55.9	51.3	43.3	43.7	43.5	35.8	29.9	

注)カウンタウエイト 16.5t、アウトリガ張出幅 5.5m
 または、カウンタウエイト 7.5t、アウトリガ張出幅 6.8m

■M性能

ESPブーム										単位:t
性能ブロック	1									
性能番号	1	2	3	4	5	6	7	8	9	
ブーム長さ(m)	15.0	20.1	25.1	30.2	35.3	40.4	45.4	50.5	55.6	
作業半径(m)										
3.0	170.0									
3.5	170.0	117.6								
4.0	155.1	111.1	82.5	85.5						
4.5	116.5	105.3	77.5	80.2						
5.0	88.3	91.1	73.0	75.5	67.9					
6.0	57.9	60.2	61.6	63.1	60.7	62.7				
7.0	41.9	43.9	45.2	46.4	46.4	47.0	46.5			
8.0	32.0	33.9	35.0	36.1	36.1	36.6	36.1	35.7		
9.0	25.2	27.0	28.1	29.1	29.1	29.6	29.1	28.7	28.0	
10.0	20.4	22.1	23.1	24.0	24.1	24.5	24.0	23.6	22.9	
11.0	16.7	18.3	19.3	20.2	20.2	20.6	20.2	19.8	19.1	
12.0	13.9	15.4	16.3	17.2	17.2	17.6	17.2	16.8	16.1	
14.0		11.2	12.0	12.8	12.8	13.1	12.7	12.4	11.7	
16.0		8.2	9.0	9.8	9.8	10.0	9.6	9.3	8.7	
18.0		5.9	6.6	7.4	7.4	7.7	7.2	6.8		
20.0			4.7	5.5	5.4	5.7	5.2			
22.0			3.2	3.9	3.8	4.0				
24.0				2.7	2.5	2.7				
ピン無最大荷重	62.0	70.3	50.4	67.0	52.0	62.1	46.5	35.7	28.0	
θ (°)	0~80	0~80	0~81	0~84.5	0~84.5	50~84.5	62~84.5	68~84.5	73~84.5	
伸長状態 (伸長割合%)										
伸縮ブーム1	0	0	0	0	0	0	0	45	90	
伸縮ブーム2	0	0	0	0	0	45	90	90	90	
伸縮ブーム3	0	0	0	45	90	90	90	90	90	
伸縮ブーム4	0	45	90	90	90	90	90	90	90	
標準フック	170t	170t	170t	170t	80t	80t	80t	80t	80t	
フック質量	3200kg	3200kg	3200kg	3200kg	1270kg	1270kg	1270kg	1270kg	1270kg	
補巻時・標準巻掛本数	18	13	8	9	7	6	5	4	3	
主巻時・標準巻掛本数	18	13	8	9	7	6	5	4	3	
主巻時・最大荷重	170.0	117.6	82.5	85.5	67.9	62.7	46.5	35.7	28.0	

注)カウンタウエイト 7.5t、アウトリガ張出幅 5.5m

または、カウンタウエイト 0t、アウトリガ張出幅 8.5m

または、カウンタウエイト 0t、アウトリガ張出幅 8.0m

■N性能

ESPブーム										単位:t
性能ブロック	1									
性能番号	1	2	3	4	5	6	7	8	9	
ブーム長さ(m)	15.0	20.1	25.1	30.2	35.3	40.4	45.4	50.5	55.6	
作業半径(m)										
3.0	170.0									
3.5	170.0	117.6								
4.0	163.8	111.1	82.5	85.5						
4.5	147.1	105.3	77.5	80.2						
5.0	100.8	100.1	73.0	75.5	67.9					
6.0	58.1	61.2	63.1	64.8	60.7	62.7				
7.0	39.1	41.6	43.2	44.6	44.7	45.3	44.7			
8.0	28.3	30.6	32.0	33.2	33.3	33.8	33.3	32.7		
9.0	21.5	23.6	24.8	25.9	26.0	26.4	25.9	25.4	24.6	
10.0	16.7	18.6	19.8	20.9	20.9	21.3	20.8	20.4	19.6	
11.0	13.2	15.0	16.1	17.1	17.1	17.5	17.1	16.6	15.9	
12.0	10.6	12.3	13.3	14.2	14.3	14.6	14.2	13.7	13.0	
14.0		8.4	9.3	10.1	10.2	10.5	10.0	9.6	9.0	
16.0		5.6	6.6	7.4	7.4	7.6	7.2	6.8		
18.0		3.6	4.5	5.4	5.3	5.6	5.1			
20.0			2.8	3.7	3.6	3.8				
22.0				2.3	2.3					
ピン無最大荷重	62.0	70.3	50.4	67.0	52.0	62.1	44.7	32.7	24.6	
θ (°)	0~80	0~80	0~81	0~84.5	46~84.5	57~84.5	65~84.5	70~84.5	75~84.5	
伸長状態 (伸長割合%)										
伸縮ブーム1	0	0	0	0	0	0	0	45	90	
伸縮ブーム2	0	0	0	0	0	45	90	90	90	
伸縮ブーム3	0	0	0	45	90	90	90	90	90	
伸縮ブーム4	0	45	90	90	90	90	90	90	90	
標準フック	170t	170t	170t	170t	80t	80t	80t	80t	80t	
フック質量	3200kg	3200kg	3200kg	3200kg	1270kg	1270kg	1270kg	1270kg	1270kg	
補巻時・標準巻掛本数	18	13	8	9	7	6	5	3	3	
主巻時・標準巻掛本数	18	13	8	9	7	6	5	3	3	
主巻時・最大荷重	170.0	117.6	82.5	85.5	67.9	62.7	44.7	32.7	24.6	

注)カウンタウエイト 0t、アウトリガ張出幅 6.8m

■O性能

ESPブーム		単位:t							
性能ブロック	1								
性能番号	1	2	3	4	5	6	7	8	
ブーム長さ(m)	15.0	20.1	25.1	30.2	35.3	40.4	45.4	50.5	
作業半径(m)									
3.0	170.0								
3.5	165.8	117.6							
4.0	109.1	111.1	82.5	85.5					
4.5	75.0	78.5	77.5	80.2					
5.0	56.0	59.0	60.9	62.6	62.7				
6.0	35.6	38.0	39.6	40.9	41.0	41.6			
7.0	24.8	27.0	28.3	29.5	29.6	30.0	29.5		
8.0	18.1	20.1	21.3	22.4	22.5	22.9	22.4	21.9	
9.0	13.6	15.5	16.6	17.6	17.6	18.0	17.6	17.1	
10.0	10.3	12.1	13.2	14.1	14.2	14.5	14.1	13.6	
11.0	7.8	9.6	10.6	11.5	11.5	11.8	11.4	11.0	
12.0	5.7	7.6	8.6	9.4	9.4	9.8	9.4	9.0	
14.0		4.5	5.6	6.4	6.4	6.7	6.3		
16.0		2.3	3.3	4.2	4.2	4.5			
18.0				2.5					
ピン無最大荷重	62.0	70.3	50.4	67.0	52.0	41.6	29.5	21.9	
θ(°)	0~80	0~80	0~81	47~84.5	59~84.5	64~84.5	70~84.5	75~84.5	
伸長状態(伸長割合%)									
伸縮ブーム1	0	0	0	0	0	0	0	45	
伸縮ブーム2	0	0	0	0	0	45	90	90	
伸縮ブーム3	0	0	0	45	90	90	90	90	
伸縮ブーム4	0	45	90	90	90	90	90	90	
標準フック	170t	170t	170t	170t	80t	80t	80t	80t	
フック質量	3200kg	3200kg	3200kg	3200kg	1270kg	1270kg	1270kg	1270kg	
補巻時・標準巻掛本数	18	13	8	9	6	4	3	3	
主巻時・標準巻掛本数	18	13	8	9	6	4	3	3	
主巻時・最大荷重	170.0	117.6	82.5	85.5	62.7	41.6	29.5	21.9	

注)カウンタウエイト 0t、アウトリガ張出幅 5.5m

■P性能

ESPブーム		単位:t			
性能ブロック	1				
性能番号	1	2	3	4	
ブーム長さ(m)	15.0	20.1	25.1	30.2	
作業半径(m)					
3.0	25.0				
3.5	25.0	25.0			
4.0	25.0	25.0	25.0	25.0	
4.5	25.0	25.0	25.0	25.0	
5.0	25.0	25.0	25.0	25.0	
6.0	25.0	25.0	25.0	25.0	
7.0	25.0	25.0	25.0	25.0	
8.0	25.0	25.0	25.0	25.0	
9.0	25.0	25.0	25.0	25.0	
10.0	25.0	25.0	25.0	25.0	
11.0	19.3	21.6	23.0	24.2	
12.0	15.1	17.3	18.5	19.7	
14.0		11.5	12.6	13.6	
16.0		8.0	8.9	9.8	
18.0		5.6	6.4	7.2	
20.0			4.5	5.3	
22.0			3.0	3.7	
24.0				2.5	
ピン無最大荷重	25.0	25.0	25.0	25.0	
θ(°)	0~80	0~80	0~81	0~84.5	
伸長状態(伸長割合%)					
伸縮ブーム1	0	0	0	0	
伸縮ブーム2	0	0	0	0	
伸縮ブーム3	0	0	0	45	
伸縮ブーム4	0	45	90	90	
標準フック	80t	80t	80t	80t	
フック質量	1270kg	1270kg	1270kg	1270kg	
補巻時・標準巻掛本数	3	3	3	3	
主巻時・標準巻掛本数	3	3	3	3	
主巻時・最大荷重	25.0	25.0	25.0	25.0	

注)カウンタウエイト 0t、アウトリガ張出幅 2.7m、後方のみ

■Q性能

ESPブーム		単位:t			
性能ブロック	1				
性能番号	1	2	3	4	
ブーム長さ(m)	15.0	20.1	25.1	30.2	
作業半径(m)					
3.0	25.0				
3.5	25.0	25.0			
4.0	22.4	24.5	25.0	25.0	
4.5	17.2	19.2	20.4	21.5	
5.0	13.5	15.3	16.5	17.5	
6.0	8.3	10.1	11.1	12.1	
7.0	4.8	6.7	7.7	8.6	
ピン無最大荷重	25.0	25.0	25.0	25.0	
θ(°)	49~80	61~80	68~81	72~84.5	
伸長状態(伸長割合%)					
伸縮ブーム1	0	0	0	0	
伸縮ブーム2	0	0	0	0	
伸縮ブーム3	0	0	0	45	
伸縮ブーム4	0	45	90	90	
標準フック	80t	80t	80t	80t	
フック質量	1270kg	1270kg	1270kg	1270kg	
補巻時・標準巻掛本数	3	3	3	3	
主巻時・標準巻掛本数	3	3	3	3	
主巻時・最大荷重	25.0	25.0	25.0	25.0	

注)カウンタウエイト 0t、アウトリガ張出幅 2.7m

3. フルオートラフィングジブ定格総荷重表

1. 定格総荷重表の性能区分 **FC**～**FI** は、下表のとおりです。

カウンタウェイト アウトリガ 張出幅	118 t	98 t	78 t	58 t	47 t	25 t
8.5m	FC	FD	FE	FF	FG	FI
8.0m	FC	FD	FE	FF	FG	FI
6.8m			FF	FG	FH	

2. 定格総荷重は、つり具質量とフック質量（80トフック：1,270 kg、25トフック：870 kg、11.3トフック：440 kg）を含んだ値を示します。

3. 定格総荷重は、ブームのたわみを含んだ実際の作業半径に基づいています。

4. 各ブーム長さにおける各ブーム段の伸長状態（伸長割合%）は、下表のとおりです。

ブーム長さ	40.4m	45.4m	50.5m	55.6m	60.0m
伸縮ブーム1	90	90	90	90	100
伸縮ブーム2	90	90	90	90	100
伸縮ブーム3	45	90	90	90	100
伸縮ブーム4	0	0	45	90	100

5. 定格総荷重表中の標準巻掛本数よりも少ない本数で使用する場合、最大荷重の上限は下表のとおりです。

掛数	3本	2本	1本
最大荷重	33.5 t	22.5 t	11.3 t

6. Bピン（ブーム固定ピン）を挿入していないときの定格総荷重は、32.0 t 以下になります。

7. 定格総荷重は、アウトリガを水平堅土上に設置したときの値です。

8. 定格総荷重表は、風による影響を含んでいません。瞬間最大風速が 10m/s 以上の風速では、クレーン作業を中止してください。

9. 定格総荷重表中の太線より上側はクレーンの強度に、下側はクレーンの安定に基づいています。

10. 「 θ (°)」は、無負荷状態で作動可能なブーム起伏角度範囲を示します。

11. 「オフセット」は下図のようにブームの中心線とジブの中心線とのなす角度を示します。

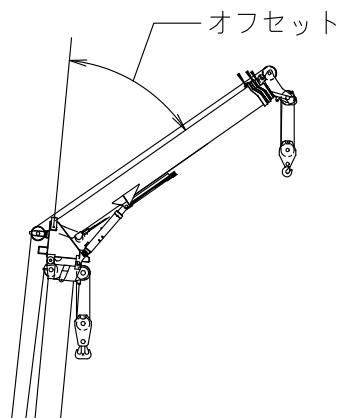

■FC性能

40. 4mブーム+1.6m+フルオートラフィングジブ

単位:t

ジブ長さ(m)	10.3m					17.2m					24.1m					31.0m								
	オフセット					オフセット					オフセット					オフセット								
	5°	15°	30°	45°	60°	5°	15°	30°	45°	60°	5°	15°	30°	45°	60°	5°	15°	30°	45°	60°				
9.0	39.9																							
10.0	37.4								16.7															
11.0	35.2	33.2							16.7															
12.0	33.3	31.5							16.7															
14.0	29.9	28.4	26.8						16.7	16.7					16.1									
16.0	27.0	25.9	24.5	23.6	22.7				16.7	16.7					15.6				10.9					
18.0	24.6	23.7	22.6	21.8	21.3				16.7	16.7	16.7				15.2	13.8			10.8					
20.0	22.6	21.8	20.9	20.2	19.8				16.7	16.7	16.7				14.7	13.3			10.6					
22.0	20.8	20.2	19.4	18.9	18.5				16.7	16.7	16.7	14.4			14.2	12.8			10.3	9.4				
24.0	19.3	18.7	18.1	17.6	17.4				16.7	16.7	16.2	14.0	12.9		13.7	12.4			10.1	9.0				
26.0	16.8	17.2	16.9	16.5	16.3				16.7	16.1	15.4	13.7	12.7		13.2	12.0	10.8		9.8	8.6				
28.0	14.7	15.0	15.3	15.4	15.4				15.6	15.0	14.4	13.3	12.5		12.8	11.7	10.4		9.4	8.3				
30.0	12.7	13.0	13.4	13.6					14.0	14.1	13.6	13.0	12.4		12.4	11.4	10.1	9.3	9.0	7.9	6.9			
32.0	11.1	11.3	11.7	11.8					12.4	12.7	12.8	12.5	12.3		12.0	11.1	9.8	9.1	8.4	8.6	7.6	6.6		
34.0	9.6	9.8	10.1	10.2					10.9	11.3	11.7	11.8	11.7		11.6	10.7	9.5	8.9	8.2	8.3	7.4	6.4		
36.0	8.2	8.5	8.7	8.8					9.6	10.0	10.4	10.7			10.4	10.4	9.3	8.7	8.1	8.0	7.1	6.2	5.7	
38.0	7.0	7.2	7.4						8.4	8.8	9.2	9.5			9.3	9.7	9.1	8.5	8.1	7.7	6.9	6.0	5.5	
40.0	5.9	6.1	6.3						7.4	7.7	8.2	8.4			8.3	8.7	8.9	8.3		7.4	6.6	5.9	5.4	5.1
42.0	5.0	5.1	5.2						6.4	6.7	7.1	7.3			7.3	7.7	8.2	8.2		7.1	6.4	5.7	5.3	5.1
44.0	4.1	4.2	4.2						5.5	5.8	6.1	6.2			6.5	6.9	7.3	7.6		6.9	6.2	5.6	5.2	5.0
46.0	3.2	3.3							4.7	4.9	5.2				5.7	6.1	6.5	6.8		6.6	6.0	5.4	5.1	5.0
48.0	2.5	2.5							3.9	4.2	4.4				4.9	5.3	5.8	6.0		5.9	5.9	5.3	5.0	
50.0									3.2	3.4	3.6				4.3	4.6	5.0			5.3	5.7	5.2	4.9	
54.0									2.0	2.1					3.0	3.3	3.6			4.0	4.5	4.9	4.7	
58.0															2.0	2.2				3.0	3.3	3.8		
62.0																				2.1	2.3	2.6		
θ(°)	20~84.5	21~84.5	34~84.5	51~84.5	64~84.5	24~84.5	26~84.5	37~84.5	50~84.5	66~84.5	30~84.5	33~84.5	45~84.5	57~84.5	73~84.5	34~84.5	38~84.5	43~84.5	59~84.5	72~84.5				
標準フック	80t										25t					11.3t								
フック質量	1270kg										870kg					440kg								
標準巻掛本数	4										2					1								

注)カウンタウエイト 118t、アウトリガ張出幅 8.5m

または、カウンタウエイト 118t、アウトリガ張出幅 8.0m

■FC性能

45. 4mブーム+1.6m+フルオートラフィングジブ

単位:t

ジブ長さ(m)	10.3m					17.2m					24.1m					31.0m								
	オフセット					オフセット					オフセット					オフセット								
	5°	15°	30°	45°	60°	5°	15°	30°	45°	60°	5°	15°	30°	45°	60°	5°	15°	30°	45°	60°				
10.0	29.6																							
11.0	28.4								16.7															
12.0	26.9	25.0							16.7															
14.0	24.2	22.7							16.7															
16.0	22.0	20.8	19.4	18.4					16.7	16.7					14.8					10.4				
18.0	20.2	19.1	17.9	17.1	16.6				16.7	16.7					14.4					10.2				
20.0	18.6	17.7	16.6	16.0	15.5				16.7	15.8	14.6				14.1	13.0				10.0				
22.0	17.2	16.4	15.5	14.9	14.6				15.7	14.7	13.7				13.7	12.6				9.8				
24.0	15.9	15.3	14.5	14.0	13.7				14.5	13.7	12.8	12.2	11.8		13.4	12.2				9.6	8.8			
26.0	14.9	14.3	13.6	13.2	13.0				13.5	12.8	12.0	11.5	11.1		12.5	11.7				9.4	8.5			
28.0	13.6	13.4	12.8	12.4	12.3				12.7	12.0	11.3	10.8	10.5		11.7	11.0	10.2			9.3	8.1			
30.0	11.8	12.0	12.1	11.8	11.6				11.9	11.3	10.7	10.2	10.0		10.9	10.3	9.7			8.9	7.8			
32.0	10.2	10.5	10.7	10.9					11.1	10.6	10.1	9.7	9.5		10.3	9.7	9.1	8.7		8.6	7.6	6.5		
34.0	8.8	9.0	9.3	9.5					9.9	10.0	9.5	9.2	9.1		9.7	9.2	8.6	8.3	8.1	8.2	7.3	6.3		
36.0	7.4	7.7	8.0	8.1					8.7	9.1	9.0	8.8	8.6		9.1	8.7	8.2	7.9	7.7	7.9	7.0	6.2	5.6	
38.0	6.3	6.5	6.8	6.9					7.6	8.0	8.4	8.3	8.2		8.3	8.2	7.8	7.5	7.3	7.6	6.8	6.0	5.5	
40.0	5.2	5.4	5.7	5.7					6.6	6.9	7.4	7.6			7.4	7.7	7.3	7.0	6.9	7.4	6.6	5.8	5.4	5.1
42.0	4.2	4.4	4.6						5.7	6.0	6.4	6.6			6.5	6.9	6.8	6.6		7.1	6.4	5.7	5.2	5.1
44.0	3.3	3.5	3.7						4.8	5.1	5.5	5.7			5.7	6.1	6.3	6.1		6.5	6.2	5.5	5.1	5.0
46.0	2.5	2.7	2.8						4.0	4.3	4.7	4.8			4.9	5.3	5.7	5.7		5.8	6.0	5.4	5.0	4.9
48.0									3.2	3.5	3.9	4.0			4.2	4.6	5.1	5.3		5.1	5.5	5.2	4.9	4.9
50.0									2.6	2.8	3.1				3.6	4.0	4.4	4.7		4.5	4.9	5.0	4.8	
54.0															2.4	2.7	3.1			3.4	3.8	4.2	4.2	
58.0																	1.9			2.4	2.7	3.2	3.5	
62.0																					1.8	2.2		
θ(°)	37~84.5	38~84.5	39~84.5	50~84.5	65~84.5	42~84.5	44~84.5	46~84.5	50~84.5	65~84.5	43~84.5	47~84.5	45~84.5	58~84.5	72~84.5	45~84.5	50~84.5	58~84.5	72~84.5					
標準フック	80t										25t					11.3t								
フック質量	1270kg										870kg					440kg								
標準巻掛本数	4										2					1								

注)カウンタウエイト 118t、アウトリガ張出幅 8.5m

または、カウンタウエイト 118t、アウトリガ張出幅 8.0m

■FC性能

50. 5mブーム+1. 6m+フルオートラフィングジブ

単位:t

ジブ長さ(m)	10.3m					17.2m					24.1m					31.0m				
	オフセット					オフセット					オフセット					オフセット				
	5°	15°	30°	45°	60°	5°	15°	30°	45°	60°	5°	15°	30°	45°	60°	5°	15°	30°	45°	60°
11.0	20.8																			
12.0	19.8																			
14.0	18.0	16.3				15.8														
16.0	16.5	15.1	13.5			14.4	12.8				12.8									
18.0	15.0	14.0	12.7	11.8	11.2	13.3	11.9				11.8					9.1				
20.0	13.7	13.0	11.9	11.1	10.6	12.3	11.1				10.9	9.7				9.1				
22.0	12.6	12.1	11.2	10.5	10.1	11.4	10.4	9.2			10.1	9.0				9.1				
24.0	11.6	11.1	10.5	10.0	9.6	10.7	9.7	8.7	8.0		9.5	8.5				8.8				
26.0	10.7	10.3	9.9	9.5	9.2	10.0	9.1	8.2	7.6	7.2	8.8	8.0	7.0			8.2	7.4			
28.0	9.9	9.6	9.2	9.0	8.8	9.3	8.6	7.8	7.3	6.9	8.3	7.5	6.7			7.7	6.9			
30.0	8.9	8.7	8.4	8.2	8.0	8.6	8.2	7.4	6.9	6.6	7.8	7.1	6.3			7.3	6.5			
32.0	8.0	7.8	7.5	7.4	7.3	7.8	7.6	7.0	6.6	6.4	7.4	6.7	6.0	5.5		6.8	6.2	5.5		
34.0	7.2	7.0	6.8	6.7		7.1	6.9	6.6	6.3	6.1	6.8	6.4	5.7	5.3	5.0	6.5	5.9	5.2		
36.0	6.4	6.3	6.1	6.0		6.4	6.2	6.0	5.9	5.7	6.1	6.0	5.4	5.1	4.8	6.1	5.5	5.0		
38.0	5.8	5.6	5.5	5.4		5.7	5.6	5.4	5.3	5.2	5.5	5.4	5.2	4.8	4.5	5.7	5.3	4.7	4.3	
40.0	4.8	5.0	4.9	4.9		5.1	5.0	4.9	4.8	4.7	5.0	4.9	4.8	4.5	4.3	5.2	5.0	4.4	4.0	
42.0	3.9	4.1	4.3	4.3		4.6	4.5	4.4	4.3		4.5	4.4	4.3	4.2	4.0	4.7	4.6	4.2	3.8	3.5
44.0	3.0	3.2	3.4	3.5		4.1	4.0	4.0	3.9		4.0	4.0	3.9	3.9		4.2	4.2	3.9	3.5	3.3
46.0		2.4	2.6			3.5	3.6	3.5	3.5		3.6	3.5	3.5	3.5		3.8	3.8	3.6	3.3	3.1
48.0						2.8	3.2	3.1	3.1		3.2	3.2	3.1	3.1		3.4	3.4	3.4	3.1	2.9
50.0						2.2	2.5	2.8	2.7		2.8	2.8	2.8	2.8		3.0	3.0	3.0	2.9	2.8
54.0											1.9	2.1	2.2	2.2		2.4	2.4	2.4	2.4	
58.0																1.8	1.8	1.9	1.9	
θ(°)	46~84.5	45~84.5	46~84.5	49~84.5	66~84.5	46~84.5	48~84.5	51~84.5	52~84.5	65~84.5	48~84.5	51~84.5	55~84.5	57~84.5	72~84.5	49~84.5	54~84.5	59~84.5	62~84.5	73~84.5
標準フック	25t															11.3t				
フック質量	870kg															440kg				
標準巻掛本数	2															1				

注)カウンタウエイト 118t、アウトリガ張出幅 8.5m

または、カウンタウエイト 118t、アウトリガ張出幅 8.0m

■FC性能

55. 6mブーム+1. 6m+フルオートラフィングジブ

単位:t

ジブ長さ(m)	10.3m					17.2m					24.1m					31.0m				
	オフセット					オフセット					オフセット					オフセット				
	5°	15°	30°	45°	60°	5°	15°	30°	45°	60°	5°	15°	30°	45°	60°	5°	15°	30°	45°	60°
12.0	14.6																			
14.0	14.6	13.7																		
16.0	13.4	12.5				12.0														
18.0	12.3	11.5	10.6	10.0		11.0	10.0				9.4									
20.0	11.2	10.6	9.8	9.3	8.9	10.0	9.2				9.4					6.4				
22.0	10.3	9.8	9.1	8.6	8.4	9.2	8.5	7.8			8.7	8.0				6.4				
24.0	9.6	9.0	8.5	8.1	7.8	8.5	7.9	7.2			8.1	7.4				6.4				
26.0	8.6	8.4	7.9	7.6	7.4	7.9	7.4	6.8	6.4		7.5	6.9				6.4	6.3			
28.0	7.6	7.5	7.3	7.1	6.9	7.3	6.9	6.3	6.0	5.7	6.9	6.4	5.8			6.4	5.9			
30.0	6.6	6.5	6.4	6.3	6.2	6.6	6.4	5.9	5.5	5.3	6.5	6.0	5.5			6.0	5.5			
32.0	5.8	5.7	5.6	5.6	5.5	5.8	5.7	5.4	5.1	4.9	6.0	5.6	5.1			5.6	5.2			
34.0	5.0	5.0	4.9	4.8	4.8	5.0	5.0	4.9	4.6	4.4	5.4	5.1	4.7	4.4		5.1	4.7	4.3		
36.0	4.3	4.3	4.2	4.2		4.4	4.4	4.4	4.2	4.1	4.7	4.6	4.2	4.0	3.8	4.6	4.3	3.9		
38.0	3.6	3.6	3.6	3.6		3.8	3.8	3.8	3.8	3.7	4.2	4.2	3.9	3.6	3.5	4.2	3.9	3.6		
40.0	3.0	3.0	3.0	3.0		3.2	3.3	3.3	3.3	3.3	3.6	3.7	3.5	3.3	3.2	3.8	3.5	3.3	3.1	
42.0	2.5	2.5	2.5	2.5		2.7	2.8	2.8	2.9	2.8	3.1	3.2	3.2	3.0	2.9	3.3	3.2	2.9	2.8	
44.0	2.0	2.0	2.0	2.0		2.2	2.3	2.4	2.4		2.7	2.8	2.8	2.7	2.6	2.8	2.9	2.7	2.5	2.4
46.0							1.9	2.0	2.0		2.2	2.3	2.5	2.4		2.4	2.6	2.4	2.3	2.2
48.0											1.8	2.0	2.1	2.2		2.0	2.2	2.1	2.0	1.9
50.0											1.5	1.6	1.7	1.8		1.7	1.9	1.9	1.8	1.7
θ(°)	51~84.5	52~84.5	54~84.5	66~84.5	56~84.5	57~84.5	60~84.5	61~84.5	66~84.5	56~84.5	59~84.5	63~84.5	65~84.5	73~84.5	61~84.5	64~84.5	69~84.5	73~84.5	75~84.5	
標準フック	25t															11.3t				
フック質量	870kg															440kg				
標準巻掛本数	2															1				

注)カウンタウエイト 118t、アウトリガ張出幅 8.5m

または、カウンタウエイト 118t、アウトリガ張出幅 8.0m

■FC性能

60. 0mブーム+1. 6m+フルオートラフィングジブ

単位:t

ジブ長さ(m)	10.3m					17.2m					24.1m					31.0m				
	オフセット					オフセット					オフセット					オフセット				
	5°	15°	30°	45°	60°	5°	15°	30°	45°	60°	5°	15°	30°	45°	60°	5°	15°	30°	45°	
14.0	12.0																			
16.0	11.7	11.0				8.0														
18.0	10.7	10.0	9.3			8.0					7.1									
20.0	9.7	9.2	8.6	8.2		8.0	8.0				7.1									
22.0	8.9	8.5	7.9	7.6	7.3	8.0	7.8				7.1					5.7				
24.0	8.2	7.8	7.4	7.1	6.9	7.7	7.2	6.6			7.1	6.6				5.7				
26.0	7.1	7.1	6.8	6.6	6.4	7.1	6.7	6.2			6.6	6.1				5.7				
28.0	6.2	6.1	6.1	6.0	5.8	6.5	6.2	5.8	5.5		6.1	5.7				5.7	5.3			
30.0	5.3	5.3	5.2	5.2	5.1	5.7	5.7	5.3	5.0	4.8	5.7	5.3	4.9			5.3	5.0			
32.0	4.5	4.5	4.5	4.5	4.4	4.9	5.0	4.8	4.5	4.3	5.1	4.8	4.4			4.8	4.5			
34.0	3.8	3.8	3.8	3.8	3.8	4.2	4.3	4.3	4.1	3.9	4.4	4.3	4.0	3.8		4.3	4.1			
36.0	3.1	3.2	3.2	3.2	3.2	3.6	3.7	3.8	3.7	3.5	3.8	3.8	3.6	3.4		3.9	3.7	3.4		
38.0	2.5	2.6	2.6	2.6	2.6	3.0	3.1	3.2	3.3	3.2	3.3	3.4	3.2	3.1	2.9	3.5	3.3	3.1		
40.0		2.0	2.1	2.1	2.1	2.5	2.6	2.7	2.8	2.7	2.8	2.9	2.9	2.7	2.6	3.0	2.9	2.7		
42.0						2.0	2.1	2.2	2.3	2.3	2.3	2.5	2.6	2.4	2.3	2.5	2.6	2.4	2.3	
44.0						1.6	1.7	1.8	1.9	1.9	1.9	2.0	2.2	2.2	2.1	2.1	2.3	2.2	2.1	
46.0											1.5	1.6	1.8	1.9	1.8	1.7	1.9	1.9	1.8	
48.0															1.6				1.6	
θ(°)	61~84.5	60~84.5	61~84.5	62~84.5	69~84.5	60~84.5	62~84.5	65~84.5	66~84.5	69~84.5	62~84.5	65~84.5	69~84.5	70~84.5	73~84.5	66~84.5	67~84.5	72~84.5	76~84.5	
標準フック	25t					11.3t					11.3t					11.3t				
フック質量	870kg					870kg					440kg					440kg				
標準巻掛本数	2					2					1					1				

注)カウンタウエイト 118t、アウトリガ張出幅 8.5m
または、カウンタウエイト 118t、アウトリガ張出幅 8.0m

■FD性能

40. 4mブーム+1. 6m+フルオートラフィングジブ

単位:t

ジブ長さ(m)	10.3m					17.2m					24.1m					31.0m				
	オフセット					オフセット					オフセット					オフセット				
	5°	15°	30°	45°	60°	5°	15°	30°	45°	60°	5°	15°	30°	45°	60°	5°	15°	30°	45°	60°
9.0	39.9																			
10.0	37.4					16.7														
11.0	35.2	33.2				16.7														
12.0	33.3	31.5				16.7														
14.0	29.9	28.4	26.8			16.7	16.7				16.1									
16.0	27.0	25.9	24.5	23.6	22.7	16.7	16.7				15.6					10.9				
18.0	24.6	23.7	22.6	21.8	21.3	16.7	16.7	16.7			15.2	13.8				10.8				
20.0	22.6	21.8	20.9	20.2	19.8	16.7	16.7	16.7			14.7	13.3				10.6				
22.0	20.8	20.2	19.4	18.9	18.5	16.7	16.7	16.7	14.4		14.2	12.8				10.3	9.4			
24.0	19.3	18.7	18.1	17.6	17.4	16.7	16.7	16.2	14.0	12.9	13.7	12.4				10.1	9.0			
26.0	16.8	17.2	16.9	16.5	16.3	16.7	16.1	15.4	13.7	12.7	13.2	12.0	10.8			9.8	8.6			
28.0	14.7	15.0	15.3	15.4	15.4	15.6	15.0	14.4	13.3	12.5	12.8	11.7	10.4			9.4	8.3			
30.0	12.7	13.0	13.4	13.6	13.6	14.0	14.1	13.6	13.0	12.4	12.4	11.4	10.1	9.3		9.0	7.9	6.9		
32.0	11.1	11.3	11.7	11.8	11.8	12.4	12.7	12.8	12.5	12.3	12.0	11.1	9.8	9.1	8.4	8.6	7.6	6.6		
34.0	9.6	9.8	10.1	10.2	10.2	10.9	11.3	11.7	11.8	11.7	11.6	10.7	9.5	8.9	8.2	8.3	7.4	6.4		
36.0	8.2	8.5	8.7	8.8	8.8	9.6	10.0	10.4	10.7	10.7	10.4	10.4	9.3	8.7	8.1	8.0	7.1	6.2	5.7	
38.0	7.0	7.2	7.4	7.4	7.4	8.4	8.8	9.2	9.5	9.5	9.3	9.7	9.1	8.5	8.1	7.7	6.9	6.0	5.5	
40.0	5.9	6.1	6.3	6.3	6.3	7.4	7.7	8.2	8.4	8.4	8.3	8.7	8.9	8.3	8.3	7.4	6.6	5.9	5.4	5.1
42.0	4.5	4.8	5.1	5.1	5.1	6.4	6.7	7.1	7.3	7.3	7.3	7.7	8.2	8.2	8.2	7.1	6.4	5.7	5.3	5.1
44.0	3.2	3.4	3.5	3.5	3.5	5.5	5.8	6.1	6.2	6.2	6.5	6.9	7.3	7.6	7.6	6.9	6.2	5.6	5.2	5.0
46.0						4.7	4.9	5.2	5.2	5.2	5.7	6.1	6.5	6.8	6.8	6.6	6.0	5.4	5.1	5.0
48.0						3.6	4.0	4.4	4.4	4.4	4.9	5.3	5.8	6.0	6.0	5.9	5.9	5.3	5.0	5.0
50.0						2.5	2.9	3.2	3.2	3.2	4.3	4.6	5.0	5.0	5.0	5.3	5.7	5.2	4.9	4.9
54.0											2.7	3.3	3.6	3.6	3.6	4.0	4.5	4.9	4.7	4.7
58.0																2.9	3.3	3.8	3.8	3.8
62.0																1.6	2.1	2.6	2.6	2.6
θ(°)	32~84.5	33~84.5	34~84.5	51~84.5	64~84.5	34~84.5	36~84.5	37~84.5	50~84.5	66~84.5	37~84.5	41~84.5	45~84.5	57~84.5	73~84.5	34~84.5	38~84.5	43~84.5	59~84.5	72~84.5
標準フック	80t					25t					25t					11.3t				
フック質量	1270kg					870kg					870kg					440kg				
標準巻掛本数	4					2					2					1				

注)カウンタウエイト 98t、アウトリガ張出幅 8.5m
または、カウンタウエイト 98t、アウトリガ張出幅 8.0m

■FD性能

45. 4mブーム+1.6m+フルオートラフingジブ

単位:t

ジブ長さ(m)	10.3m					17.2m					24.1m					31.0m					
	オフセット					オフセット					オフセット					オフセット					
	5°	15°	30°	45°	60°	5°	15°	30°	45°	60°	5°	15°	30°	45°	60°	5°	15°	30°	45°	60°	
10.0	29.6																				
11.0	28.4					16.7															
12.0	26.9	25.0				16.7															
14.0	24.2	22.7				16.7															
16.0	22.0	20.8	19.4	18.4		16.7	16.7				14.8				10.4						
18.0	20.2	19.1	17.9	17.1	16.6	16.7	16.7				14.4				10.2						
20.0	18.6	17.7	16.6	16.0	15.5	16.7	15.8	14.6			14.1	13.0			10.0						
22.0	17.2	16.4	15.5	14.9	14.6	15.7	14.7	13.7			13.7	12.6			9.8						
24.0	15.9	15.3	14.5	14.0	13.7	14.5	13.7	12.8	12.2	11.8	13.4	12.2			9.6	8.8					
26.0	14.9	14.3	13.6	13.2	13.0	13.5	12.8	12.0	11.5	11.1	12.5	11.7			9.4	8.5					
28.0	13.6	13.4	12.8	12.4	12.3	12.7	12.0	11.3	10.8	10.5	11.7	11.0	10.2		9.3	8.1					
30.0	11.8	12.0	12.1	11.8	11.6	11.9	11.3	10.7	10.2	10.0	10.9	10.3	9.7		8.9	7.8					
32.0	10.2	10.5	10.7	10.9		11.1	10.6	10.1	9.7	9.5	10.3	9.7	9.1	8.7	8.6	7.6	6.5				
34.0	8.8	9.0	9.3	9.5		9.9	10.0	9.5	9.2	9.1	9.7	9.2	8.6	8.3	8.1	8.2	7.3	6.3			
36.0	7.4	7.7	8.0	8.1		8.7	9.1	9.0	8.8	8.6	9.1	8.7	8.2	7.9	7.7	7.9	7.0	6.2	5.6		
38.0	6.3	6.5	6.8	6.9		7.6	8.0	8.4	8.3	8.2	8.3	8.2	7.8	7.5	7.3	7.6	6.8	6.0	5.5		
40.0	5.2	5.4	5.7	5.7		6.6	6.9	7.4	7.6		7.4	7.7	7.3	7.0	6.9	7.4	6.6	5.8	5.4	5.1	
42.0	4.2	4.4	4.6			5.7	6.0	6.4	6.6		6.5	6.9	6.8	6.6		7.1	6.4	5.7	5.2	5.1	
44.0	3.2	3.5	3.7			4.8	5.1	5.5	5.7		5.7	6.1	6.3	6.1		6.5	6.2	5.5	5.1	5.0	
46.0		2.3	2.5			4.0	4.3	4.7	4.8		4.9	5.3	5.7	5.7		5.8	6.0	5.4	5.0	4.9	
48.0						3.2	3.5	3.9	4.0		4.2	4.6	5.1	5.3		5.1	5.5	5.2	4.9	4.9	
50.0						2.4	2.8	3.1			3.6	4.0	4.4	4.7		4.5	4.9	5.0	4.8		
54.0											2.4	2.7	3.1			3.4	3.8	4.2	4.2		
58.0													1.9			2.4	2.7	3.2	3.5		
62.0																1.8	2.2				
θ(°)	41~84.5	38~84.5	39~84.5	50~84.5	65~84.5	42~84.5	44~84.5	46~84.5	50~84.5	65~84.5	43~84.5	47~84.5	45~84.5	58~84.5	72~84.5	45~84.5	50~84.5	58~84.5	72~84.5		
標準フック	80t					25t					11.3t										
フック質量	1270kg					870kg					440kg										
標準巻掛本数	4					2					1										

注)カウンタウエイト 98t、アウトリガ張出幅 8.5m
または、カウンタウエイト 98t、アウトリガ張出幅 8.0m

■FD性能

50. 5mブーム+1.6m+フルオートラフingジブ

単位:t

ジブ長さ(m)	10.3m					17.2m					24.1m					31.0m					
	オフセット					オフセット					オフセット					オフセット					
	5°	15°	30°	45°	60°	5°	15°	30°	45°	60°	5°	15°	30°	45°	60°	5°	15°	30°	45°	60°	
11.0	20.8																				
12.0	19.8																				
14.0	18.0	16.3				15.8															
16.0	16.5	15.1	13.5			14.4	12.8				12.8										
18.0	15.0	14.0	12.7	11.8	11.2	13.3	11.9				11.8				9.1						
20.0	13.7	13.0	11.9	11.1	10.6	12.3	11.1				10.9	9.7			9.1						
22.0	12.6	12.1	11.2	10.5	10.1	11.4	10.4	9.2			10.1	9.0			9.1						
24.0	11.6	11.1	10.5	10.0	9.6	10.7	9.7	8.7	8.0		9.5	8.5			8.8						
26.0	10.7	10.3	9.9	9.5	9.2	10.0	9.1	8.2	7.6	7.2	8.8	8.0	7.0		8.2	7.4					
28.0	9.9	9.6	9.2	9.0	8.8	9.3	8.6	7.8	7.3	6.9	8.3	7.5	6.7		7.7	6.9					
30.0	8.9	8.7	8.4	8.2	8.0	8.6	8.2	7.4	6.9	6.6	7.8	7.1	6.3		7.3	6.5					
32.0	8.0	7.8	7.5	7.4	7.3	7.8	7.6	7.0	6.6	6.4	7.4	6.7	6.0	5.5	6.8	6.2	5.5				
34.0	7.2	7.0	6.8	6.7		7.1	6.9	6.6	6.3	6.1	6.8	6.4	5.7	5.3	5.0	6.5	5.9	5.2			
36.0	6.4	6.3	6.1	6.0		6.4	6.2	6.0	5.9	5.7	6.1	6.0	5.4	5.1	4.8	6.1	5.5	5.0			
38.0	5.8	5.6	5.5	5.4		5.7	5.6	5.4	5.3	5.2	5.5	5.4	5.2	4.8	4.5	5.7	5.3	4.7	4.3		
40.0	4.8	5.0	4.9	4.9		5.1	5.0	4.9	4.8	4.7	5.0	4.9	4.8	4.5	4.3	5.2	5.0	4.4	4.0		
42.0	3.9	4.1	4.3	4.3		4.6	4.5	4.4	4.3		4.5	4.4	4.3	4.2	4.0	4.7	4.6	4.2	3.8	3.5	
44.0	3.0	3.2	3.4	3.5		4.1	4.0	4.0	3.9		4.0	4.0	3.9	3.9		4.2	4.2	3.9	3.5	3.3	
46.0		2.4	2.6			3.5	3.6	3.5	3.5		3.6	3.5	3.5	3.5		3.8	3.8	3.6	3.3	3.1	
48.0						2.8	3.2	3.1	3.1		3.2	3.2	3.1	3.1		3.4	3.4	3.4	3.1	2.9	
50.0						2.2	2.5	2.8	2.7		2.8	2.8	2.8	2.8		3.0	3.0	3.0	2.9	2.8	
54.0											1.9	2.1	2.2	2.2		2.4	2.4	2.4	2.4		
58.0																1.8	1.8	1.9	1.9		
θ(°)	46~84.5	45~84.5	46~84.5	49~84.5	66~84.5	46~84.5	48~84.5	51~84.5	52~84.5	65~84.5	48~84.5	51~84.5	55~84.5	57~84.5	72~84.5	49~84.5	54~84.5	59~84.5	62~84.5	73~84.5	
標準フック	25t					11.3t															
フック質量	870kg					440kg															
標準巻掛本数	2					1															

注)カウンタウエイト 98t、アウトリガ張出幅 8.5m
または、カウンタウエイト 98t、アウトリガ張出幅 8.0m

■FD性能

55. 6mブーム+1. 6m+フルオートラフィングジブ

単位:t

ジブ長さ(m)	10.3m					17.2m					24.1m					31.0m					
	オフセット					オフセット					オフセット					オフセット					
	5°	15°	30°	45°	60°	5°	15°	30°	45°	60°	5°	15°	30°	45°	60°	5°	15°	30°	45°	60°	
12.0	14.6																				
14.0	14.6	13.7																			
16.0	13.4	12.5				12.0															
18.0	12.3	11.5	10.6	10.0		11.0	10.0				9.4										
20.0	11.2	10.6	9.8	9.3	8.9	10.0	9.2				9.4				6.4						
22.0	10.3	9.8	9.1	8.6	8.4	9.2	8.5	7.8			8.7	8.0			6.4						
24.0	9.6	9.0	8.5	8.1	7.8	8.5	7.9	7.2			8.1	7.4			6.4						
26.0	8.6	8.4	7.9	7.6	7.4	7.9	7.4	6.8	6.4		7.5	6.9			6.4	6.3					
28.0	7.6	7.5	7.3	7.1	6.9	7.3	6.9	6.3	6.0	5.7	6.9	6.4	5.8		6.4	5.9					
30.0	6.6	6.5	6.4	6.3	6.2	6.6	6.4	5.9	5.5	5.3	6.5	6.0	5.5		6.0	5.5					
32.0	5.8	5.7	5.6	5.6	5.5	5.8	5.7	5.4	5.1	4.9	6.0	5.6	5.1		5.6	5.2					
34.0	5.0	5.0	4.9	4.8	4.8	5.0	5.0	4.9	4.6	4.4	5.4	5.1	4.7	4.4	5.1	4.7	4.3				
36.0	4.3	4.3	4.2	4.2		4.4	4.4	4.4	4.2	4.1	4.7	4.6	4.2	4.0	3.8	4.6	4.3	3.9			
38.0	3.6	3.6	3.6	3.6		3.8	3.8	3.8	3.8	3.7	4.2	4.2	3.9	3.6	3.5	4.2	3.9	3.6			
40.0	3.0	3.0	3.0	3.0		3.2	3.3	3.3	3.3	3.3	3.6	3.7	3.5	3.3	3.2	3.8	3.5	3.3	3.1		
42.0	2.5	2.5	2.5	2.5		2.7	2.8	2.8	2.9	2.8	3.1	3.2	3.2	3.0	2.9	3.3	3.2	2.9	2.8		
44.0	2.0	2.0	2.0	2.0		2.2	2.3	2.4	2.4		2.7	2.8	2.8	2.7	2.6	2.8	2.9	2.7	2.5	2.4	
46.0							1.9	2.0	2.0		2.2	2.3	2.5	2.4		2.4	2.6	2.4	2.3	2.2	
48.0											1.8	2.0	2.1	2.2		2.0	2.2	2.1	2.0	1.9	
50.0											1.5	1.6	1.7	1.8		1.7	1.9	1.9	1.8	1.7	
θ(°)	51~84.5	52~84.5	54~84.5	60~84.5	56~84.5	57~84.5	60~84.5	61~84.5	66~84.5	56~84.5	59~84.5	63~84.5	65~84.5	73~84.5	61~84.5	64~84.5	69~84.5	73~84.5	75~84.5		
標準フック	25t										11.3t										
フック質量	870kg										440kg										
標準巻掛本数	2										1										

注)カウンタウエイト 98t、アウトリガ張出幅 8.5m
または、カウンタウエイト 98t、アウトリガ張出幅 8.0m

■FD性能

60. 0mブーム+1. 6m+フルオートラフィングジブ

単位:t

ジブ長さ(m)	10.3m					17.2m					24.1m					31.0m						
	オフセット					オフセット					オフセット					オフセット						
	5°	15°	30°	45°	60°	5°	15°	30°	45°	60°	5°	15°	30°	45°	60°	5°	15°	30°	45°			
14.0	12.0																					
16.0	11.7	11.0				8.0																
18.0	10.7	10.0	9.3			8.0					7.1											
20.0	9.7	9.2	8.6	8.2		8.0	8.0				7.1											
22.0	8.9	8.5	7.9	7.6	7.3	8.0	7.8				7.1				5.7							
24.0	8.2	7.8	7.4	7.1	6.9	7.7	7.2	6.6			7.1	6.6			5.7							
26.0	7.1	7.1	6.8	6.6	6.4	7.1	6.7	6.2			6.6	6.1			5.7							
28.0	6.2	6.1	6.1	6.0	5.8	6.5	6.2	5.8	5.5		6.1	5.7			5.7	5.3						
30.0	5.3	5.3	5.2	5.2	5.1	5.7	5.7	5.3	5.0	4.8	5.7	5.3	4.9		5.3	5.0						
32.0	4.5	4.5	4.5	4.5	4.4	4.9	5.0	4.8	4.5	4.3	5.1	4.8	4.4		4.8	4.5						
34.0	3.8	3.8	3.8	3.8	3.7	4.2	4.3	4.3	4.1	3.9	4.4	4.3	4.0	3.8	4.3	4.1						
36.0	3.1	3.2	3.2	3.2		3.6	3.7	3.8	3.7	3.5	3.8	3.8	3.6	3.4	3.9	3.7	3.4					
38.0	2.5	2.6	2.6	2.6		3.0	3.1	3.2	3.3	3.2	3.3	3.4	3.2	3.1	2.9	3.5	3.3	3.1				
40.0		2.0	2.1	2.1		2.5	2.6	2.7	2.8	2.7	2.8	2.9	2.9	2.7	2.6	3.0	2.9	2.7				
42.0						2.0	2.1	2.2	2.3	2.3	2.3	2.5	2.6	2.4	2.3	2.5	2.6	2.4	2.3			
44.0						1.6	1.7	1.8	1.9		1.9	2.0	2.2	2.2	2.1	2.1	2.3	2.2	2.1			
46.0											1.5	1.6	1.8	1.9	1.8	1.7	1.9	1.9	1.8			
48.0															1.6				1.6	1.6	1.6	
θ(°)	61~84.5	60~84.5	61~84.5	62~84.5	69~84.5	60~84.5	62~84.5	65~84.5	66~84.5	69~84.5	62~84.5	65~84.5	69~84.5	70~84.5	73~84.5	66~84.5	67~84.5	72~84.5	76~84.5			
標準フック	25t										11.3t											
フック質量	870kg										440kg											
標準巻掛本数	2										1											

注)カウンタウエイト 98t、アウトリガ張出幅 8.5m
または、カウンタウエイト 98t、アウトリガ張出幅 8.0m

■FE性能

40. 4mブーム+1.6m+フルオートラフィングジブ

単位:t

ジブ長さ(m)	10.3m					17.2m					24.1m					31.0m				
	オフセット					オフセット					オフセット					オフセット				
	5°	15°	30°	45°	60°	5°	15°	30°	45°	60°	5°	15°	30°	45°	60°	5°	15°	30°	45°	60°
9.0	39.9																			
10.0	37.4					16.7														
11.0	35.2	33.2				16.7														
12.0	33.3	31.5				16.7														
14.0	29.9	28.4	26.8			16.7	16.7				16.1									
16.0	27.0	25.9	24.5	23.6	22.7	16.7	16.7				15.6					10.9				
18.0	24.6	23.7	22.6	21.8	21.3	16.7	16.7	16.7			15.2	13.8				10.8				
20.0	22.6	21.8	20.9	20.2	19.8	16.7	16.7	16.7			14.7	13.3				10.6				
22.0	20.8	20.2	19.4	18.9	18.5	16.7	16.7	16.7	14.4		14.2	12.8				10.3	9.4			
24.0	19.3	18.7	18.1	17.6	17.4	16.7	16.7	16.2	14.0	12.9	13.7	12.4				10.1	9.0			
26.0	16.8	17.2	16.9	16.5	16.3	16.7	16.1	15.4	13.7	12.7	13.2	12.0	10.8			9.8	8.6			
28.0	14.1	15.0	15.3	15.4	15.4	15.6	15.0	14.4	13.3	12.5	12.8	11.7	10.4			9.4	8.3			
30.0	11.3	12.1	13.1	13.6		14.0	14.1	13.6	13.0	12.4	12.4	11.4	10.1	9.3		9.0	7.9	6.9		
32.0	8.9	9.6	10.4	10.8		11.9	12.7	12.8	12.5	12.3	12.0	11.1	9.8	9.1	8.4	8.6	7.6	6.6		
34.0	6.8	7.4	8.1	8.4		9.8	10.9	11.7	11.8	11.7	11.6	10.7	9.5	8.9	8.2	8.3	7.4	6.4		
36.0	5.0	5.6	6.1	6.3		7.9	9.0	10.2	10.7		10.1	10.4	9.3	8.7	8.1	8.0	7.1	6.2	5.7	
38.0	3.4	3.9	4.3			6.3	7.2	8.3	9.0		8.4	9.7	9.1	8.5	8.1	7.7	6.9	6.0	5.5	
40.0		2.4	2.7			4.8	5.6	6.6	7.2		6.9	8.1	8.9	8.3		7.4	6.6	5.9	5.4	5.1
42.0						3.5	4.2	5.1	5.5		5.6	6.7	8.1	8.2		7.1	6.4	5.7	5.3	5.1
44.0						2.3	3.0	3.7	3.9		4.4	5.4	6.7	7.6		6.3	6.2	5.6	5.2	5.0
46.0								2.4			3.3	4.2	5.4	6.1		5.2	6.0	5.4	5.1	5.0
48.0											2.3	3.1	4.1	4.7		4.2	5.3	5.3	5.0	
50.0												2.2	3.0			3.3	4.3	5.2	4.9	
54.0																1.7	2.5	3.6	4.3	
58.0																		1.8		
θ(°)	44~84.5	42~84.5	43~84.5	51~84.5	64~84.5	45~84.5	47~84.5	45~84.5	50~84.5	66~84.5	46~84.5	47~84.5	52~84.5	57~84.5	73~84.5	45~84.5	50~84.5	59~84.5	72~84.5	
標準フック	80t										25t					11.3t				
フック質量	1270kg										870kg					440kg				
標準巻掛本数	4										2					1				

注)カウンタウエイト 78t、アウトリガ張出幅 8.5m
または、カウンタウエイト 78t、アウトリガ張出幅 8.0m

■FE性能

45. 4mブーム+1.6m+フルオートラフィングジブ

単位:t

ジブ長さ(m)	10.3m					17.2m					24.1m					31.0m				
	オフセット					オフセット					オフセット					オフセット				
	5°	15°	30°	45°	60°	5°	15°	30°	45°	60°	5°	15°	30°	45°	60°	5°	15°	30°	45°	60°
10.0	29.6																			
11.0	28.4					16.7														
12.0	26.9	25.0				16.7														
14.0	24.2	22.7				16.7														
16.0	22.0	20.8	19.4	18.4		16.7	16.7				14.8					10.4				
18.0	20.2	19.1	17.9	17.1	16.6	16.7	16.7				14.4					10.2				
20.0	18.6	17.7	16.6	16.0	15.5	16.7	15.8	14.6			14.1	13.0				10.0				
22.0	17.2	16.4	15.5	14.9	14.6	15.7	14.7	13.7			13.7	12.6				9.8				
24.0	15.9	15.3	14.5	14.0	13.7	14.5	13.7	12.8	12.2	11.8	13.4	12.2				9.6	8.8			
26.0	14.9	14.3	13.6	13.2	13.0	13.5	12.8	12.0	11.5	11.1	12.5	11.7				9.4	8.5			
28.0	13.6	13.4	12.8	12.4	12.3	12.7	12.0	11.3	10.8	10.5	11.7	11.0	10.2			9.3	8.1			
30.0	11.3	12.0	12.1	11.8	11.6	11.9	11.3	10.7	10.2	10.0	10.9	10.3	9.7			8.9	7.8			
32.0	8.9	9.7	10.6	10.9		11.1	10.6	10.1	9.7	9.5	10.3	9.7	9.1	8.7		8.6	7.6	6.5		
34.0	6.9	7.5	8.3	8.8		9.7	10.0	9.5	9.2	9.1	9.7	9.2	8.6	8.3	8.1	8.2	7.3	6.3		
36.0	5.1	5.6	6.3	6.6		7.8	8.9	9.0	8.8	8.6	9.1	8.7	8.2	7.9	7.7	7.9	7.0	6.2	5.6	
38.0	3.5	4.0	4.6	4.8		6.2	7.1	8.4	8.3	8.2	8.1	8.2	7.8	7.5	7.3	7.6	6.8	6.0	5.5	
40.0		2.5	3.0	3.1		4.7	5.6	6.7	7.4		6.7	7.7	7.3	7.0	6.9	7.4	6.6	5.8	5.4	5.1
42.0						3.4	4.2	5.2	5.7		5.3	6.5	6.8	6.6		7.1	6.4	5.7	5.2	5.1
44.0						2.2	2.9	3.8	4.2		4.1	5.2	6.3	6.1		6.0	6.2	5.5	5.1	5.0
46.0								2.5	2.8		3.1	4.0	5.3	5.7		4.9	6.0	5.4	5.0	4.9
48.0											2.1	3.0	4.1	4.9		3.9	5.1	5.2	4.9	4.9
50.0												2.0	3.0			3.0	4.1	5.0	4.8	
54.0																	2.3	3.5	4.2	
58.0																		1.8	2.4	
θ(°)	50~84.5	48~84.5	50~84.5	65~84.5	50~84.5	52~84.5	53~84.5	65~84.5	50~84.5	52~84.5	56~84.5	61~84.5	72~84.5	54~84.5	55~84.5	58~84.5	72~84.5			
標準フック	80t										25t					11.3t				
フック質量	1270kg										870kg					440kg				
標準巻掛本数	4										2					1				

注)カウンタウエイト 78t、アウトリガ張出幅 8.5m
または、カウンタウエイト 78t、アウトリガ張出幅 8.0m

■FE性能

50. 5mブーム+1. 6m+フルオートラフィングジブ

単位:t

ジブ長さ(m)	10.3m					17.2m					24.1m					31.0m									
	オフセット					オフセット					オフセット					オフセット									
	5°	15°	30°	45°	60°	5°	15°	30°	45°	60°	5°	15°	30°	45°	60°	5°	15°	30°	45°	60°					
11.0	20.8																								
12.0	19.8																								
14.0	18.0	16.3				15.8																			
16.0	16.5	15.1	13.5			14.4	12.8				12.8														
18.0	15.0	14.0	12.7	11.8	11.2	13.3	11.9				11.8					9.1									
20.0	13.7	13.0	11.9	11.1	10.6	12.3	11.1				10.9	9.7				9.1									
22.0	12.6	12.1	11.2	10.5	10.1	11.4	10.4	9.2			10.1	9.0				9.1									
24.0	11.6	11.1	10.5	10.0	9.6	10.7	9.7	8.7	8.0		9.5	8.5				8.8									
26.0	10.7	10.3	9.9	9.5	9.2	10.0	9.1	8.2	7.6	7.2	8.8	8.0	7.0			8.2	7.4								
28.0	9.9	9.6	9.2	9.0	8.8	9.3	8.6	7.8	7.3	6.9	8.3	7.5	6.7			7.7	6.9								
30.0	8.9	8.7	8.4	8.2	8.0	8.6	8.2	7.4	6.9	6.6	7.8	7.1	6.3			7.3	6.5								
32.0	8.0	7.8	7.5	7.4	7.3	7.8	7.6	7.0	6.6	6.4	7.4	6.7	6.0	5.5		6.8	6.2	5.5							
34.0	7.2	7.0	6.8	6.7		7.1	6.9	6.6	6.3	6.1	6.8	6.4	5.7	5.3	5.0	6.5	5.9	5.2							
36.0	5.4	6.0	6.1	6.0		6.4	6.2	6.0	5.9	5.7	6.1	6.0	5.4	5.1	4.8	6.1	5.5	5.0							
38.0	3.8	4.3	5.0	5.3		5.7	5.6	5.4	5.3	5.2	5.5	5.4	5.2	4.8	4.5	5.7	5.3	4.7	4.3						
40.0			3.4	3.7		4.8	5.0	4.9	4.8	4.7	5.0	4.9	4.8	4.5	4.3	5.2	5.0	4.4	4.0						
42.0						3.5	4.4	4.4	4.3		4.5	4.4	4.3	4.2	4.0	4.7	4.6	4.2	3.8	3.5					
44.0						2.4	3.1	4.0	3.9		4.0	4.0	3.9	3.9		4.2	4.2	3.9	3.5	3.3					
46.0								2.8	3.3		3.1	3.5	3.5	3.5		3.8	3.8	3.6	3.3	3.1					
48.0												3.0	3.1	3.1		3.4	3.4	3.4	3.1	2.9					
50.0													2.8	2.8		2.9	3.0	3.0	2.9	2.8					
54.0																	2.3	2.4	2.4						
58.0																		1.9	1.9						
θ(°)	54~84.5		55~84.5		66~84.5	53~84.5	55~84.5	56~84.5	57~84.5	65~84.5	56~84.5	57~84.5	59~84.5	62~84.5	72~84.5	57~84.5	58~84.5	59~84.5	62~84.5	73~84.5					
標準フック																25t					11.3t				
フック質量																870kg					440kg				
標準巻掛本数																2					1				

注)カウンタウエイト 78t、アウトリガ張出幅 8.5m

または、カウンタウエイト 78t、アウトリガ張出幅 8.0m

■FE性能

55. 6mブーム+1. 6m+フルオートラフィングジブ

単位:t

ジブ長さ(m)	10.3m					17.2m					24.1m					31.0m									
	オフセット					オフセット					オフセット					オフセット									
	5°	15°	30°	45°	60°	5°	15°	30°	45°	60°	5°	15°	30°	45°	60°	5°	15°	30°	45°	60°					
12.0	14.6																								
14.0	14.6	13.7																							
16.0	13.4	12.5				12.0																			
18.0	12.3	11.5	10.6	10.0		11.0	10.0				9.4														
20.0	11.2	10.6	9.8	9.3	8.9	10.0	9.2				9.4					6.4									
22.0	10.3	9.8	9.1	8.6	8.4	9.2	8.5	7.8			8.7	8.0				6.4									
24.0	9.6	9.0	8.5	8.1	7.8	8.5	7.9	7.2			8.1	7.4				6.4									
26.0	8.6	8.4	7.9	7.6	7.4	7.9	7.4	6.8	6.4		7.5	6.9				6.4	6.3								
28.0	7.6	7.5	7.3	7.1	6.9	7.3	6.9	6.3	6.0	5.7	6.9	6.4	5.8			6.4	5.9								
30.0	6.6	6.5	6.4	6.3	6.2	6.6	6.4	5.9	5.5	5.3	6.5	6.0	5.5			6.0	5.5								
32.0	5.8	5.7	5.6	5.6	5.5	5.8	5.7	5.4	5.1	4.9	6.0	5.6	5.1			5.6	5.2								
34.0	5.0	5.0	4.9	4.8	4.8	5.0	5.0	4.9	4.6	4.4	5.4	5.1	4.7	4.4		5.1	4.7	4.3							
36.0	4.3	4.3	4.2	4.2		4.4	4.4	4.4	4.2	4.1	4.7	4.6	4.2	4.0	3.8	4.6	4.3	3.9							
38.0	3.6	3.6	3.6	3.6		3.8	3.8	3.8	3.8	3.7	4.2	4.2	3.9	3.6	3.5	4.2	3.9	3.6							
40.0		3.0	3.0	3.0		3.2	3.3	3.3	3.3	3.3	3.6	3.7	3.5	3.3	3.2	3.8	3.5	3.3	3.1						
42.0				2.5		2.7	2.8	2.8	2.9	2.8	3.1	3.2	3.2	3.0	2.9	3.3	3.2	2.9	2.8						
44.0							2.3	2.4	2.4		2.7	2.8	2.8	2.7	2.6	2.8	2.9	2.7	2.5	2.4					
46.0								2.0	2.0		2.2	2.3	2.5	2.4		2.4	2.6	2.4	2.3	2.2					
48.0											1.8	2.0	2.1	2.2		2.0	2.2	2.1	2.0	1.9					
50.0												1.6	1.7	1.8		1.7	1.9	1.9	1.8	1.7					
θ(°)	57~84.5	58~84.5	57~84.5	66~84.5	58~84.5	59~84.5	60~84.5	61~84.5	66~84.5	58~84.5	59~84.5	63~84.5	65~84.5	73~84.5	61~84.5	64~84.5	69~84.5	73~84.5	75~84.5						
標準フック																25t					11.3t				
フック質量																870kg					440kg				
標準巻掛本数																2					1				

注)カウンタウエイト 78t、アウトリガ張出幅 8.5m

または、カウンタウエイト 78t、アウトリガ張出幅 8.0m

■FE性能

60. 0mブーム+1. 6m+フルオートラフィングジブ

単位:t

ジブ長さ(m)	10.3m					17.2m					24.1m					31.0m			
	オフセット					オフセット					オフセット					オフセット			
	5°	15°	30°	45°	60°	5°	15°	30°	45°	60°	5°	15°	30°	45°	60°	5°	15°	30°	45°
14.0	12.0																		
16.0	11.7	11.0				8.0													
18.0	10.7	10.0	9.3			8.0					7.1								
20.0	9.7	9.2	8.6	8.2		8.0	8.0				7.1								
22.0	8.9	8.5	7.9	7.6	7.3	8.0	7.8				7.1					5.7			
24.0	8.2	7.8	7.4	7.1	6.9	7.7	7.2	6.6			7.1	6.6				5.7			
26.0	7.1	7.1	6.8	6.6	6.4	7.1	6.7	6.2			6.6	6.1				5.7			
28.0	6.2	6.1	6.1	6.0	5.8	6.5	6.2	5.8	5.5		6.1	5.7				5.7	5.3		
30.0	5.3	5.3	5.2	5.2	5.1	5.7	5.7	5.3	5.0	4.8	5.7	5.3	4.9			5.3	5.0		
32.0	4.5	4.5	4.5	4.5	4.4	4.9	5.0	4.8	4.5	4.3	5.1	4.8	4.4			4.8	4.5		
34.0	3.8	3.8	3.8	3.8	3.8	4.2	4.3	4.3	4.1	3.9	4.4	4.3	4.0	3.8		4.3	4.1		
36.0	3.1	3.2	3.2	3.2	3.2	3.6	3.7	3.8	3.7	3.5	3.8	3.8	3.6	3.4		3.9	3.7	3.4	
38.0	2.5	2.6	2.6	2.6		3.0	3.1	3.2	3.3	3.2	3.3	3.4	3.2	3.1	2.9	3.5	3.3	3.1	
40.0			2.1	2.1		2.5	2.6	2.7	2.8	2.7	2.8	2.9	2.9	2.7	2.6	3.0	2.9	2.7	
42.0						2.0	2.1	2.2	2.3	2.3	2.3	2.5	2.6	2.4	2.3	2.5	2.6	2.4	2.3
44.0							1.7	1.8	1.9		1.9	2.0	2.2	2.2	2.1	2.1	2.3	2.2	2.1
46.0												1.6	1.8	1.9	1.8	1.7	1.9	1.9	1.8
48.0													1.6				1.6	1.6	1.6
θ(°)	61~84.5	62~84.5	61~84.5	62~84.5	69~84.5	62~84.5	65~84.5	66~84.5	69~84.5	64~84.5	65~84.5	69~84.5	70~84.5	73~84.5	66~84.5	67~84.5	72~84.5	76~84.5	
標準フック	25t					11.3t					11.3t								
フック質量	870kg					440kg					440kg								
標準巻掛本数	2					1					1								

注)カウンタウエイト 78t、アウトリガ張出幅 8.5m
 または、カウンタウエイト 78t、アウトリガ張出幅 8.0m

■FF性能

40. 4mブーム+1. 6m+フルオートラフィングジブ

単位:t

ジブ長さ(m)	10.3m					17.2m					24.1m					31.0m				
	オフセット					オフセット					オフセット					オフセット				
	5°	15°	30°	45°	60°	5°	15°	30°	45°	60°	5°	15°	30°	45°	60°	5°	15°	30°	45°	60°
9.0	39.9																			
10.0	37.4					16.7														
11.0	35.2	33.2				16.7														
12.0	33.3	31.5				16.7														
14.0	29.9	28.4	26.8			16.7	16.7				16.1									
16.0	27.0	25.9	24.5	23.6	22.7	16.7	16.7				15.6					10.9				
18.0	24.6	23.7	22.6	21.8	21.3	16.7	16.7	16.7			15.2	13.8				10.8				
20.0	22.6	21.8	20.9	20.2	19.8	16.7	16.7	16.7			14.7	13.3				10.6				
22.0	18.2	19.3	19.4	18.9	18.5	16.7	16.7	16.7	14.4		14.2	12.8				10.3	9.4			
24.0	14.2	15.4	16.8	17.6	17.4	16.7	16.7	16.2	14.0	12.9	13.7	12.4				10.1	9.0			
26.0	10.8	11.9	13.2	14.1	14.4	14.1	15.7	15.4	13.7	12.7	13.2	12.0	10.8			9.8	8.6			
28.0	8.1	9.0	10.1	10.9	11.0	11.3	12.8	14.4	13.3	12.5	12.8	11.7	10.4			9.4	8.3			
30.0	5.8	6.6	7.5	8.1		8.9	10.3	12.1	13.0	12.4	11.1	11.4	10.1	9.3		9.0	7.9	6.9		
32.0	3.8	4.5	5.3	5.7		6.8	8.1	9.7	10.9	11.5	9.0	10.8	9.8	9.1	8.4	8.6	7.6	6.6		
34.0			3.3	3.6		5.0	6.2	7.6	8.6	9.0	7.2	8.8	9.5	8.9	8.2	8.3	7.4	6.4		
36.0						3.5	4.5	5.8	6.6		5.6	7.0	9.0	8.7	8.1	7.6	7.1	6.2	5.7	
38.0							3.0	4.1	4.8		4.2	5.5	7.3	8.5	8.1	6.2	6.9	6.0	5.5	
40.0								2.6	3.2		2.9	4.1	5.7	7.0		4.9	6.5	5.9	5.4	5.1
42.0												2.9	4.4	5.4		3.8	5.2	5.7	5.3	5.1
44.0													3.1	4.0		2.7	4.1	5.6	5.2	5.0
46.0																	3.0	4.7	5.1	5.0
48.0																		2.1	3.6	4.7
50.0																			2.6	3.6
θ(°)	53~84.5	55~84.5	54~84.5	55~84.5	64~84.5	56~84.5	55~84.5	57~84.5	66~84.5	56~84.5	57~84.5	60~84.5	63~84.5	73~84.5	56~84.5	57~84.5	60~84.5	64~84.5	72~84.5	
標準フック	80t					25t					11.3t									
フック質量	1270kg					870kg					440kg									
標準巻掛本数	4					2					1									

注)カウンタウエイト 78t、アウトリガ張出幅 6.8m
 または、カウンタウエイト 58t、アウトリガ張出幅 8.5m
 または、カウンタウエイト 58t、アウトリガ張出幅 8.0m

■FF性能

45. 4mブーム+1. 6m+フルオートラフingジブ

単位:t

ジブ長さ(m)	10.3m					17.2m					24.1m					31.0m				
	オフセット					オフセット					オフセット					オフセット				
	5°	15°	30°	45°	60°	5°	15°	30°	45°	60°	5°	15°	30°	45°	60°	5°	15°	30°	45°	60°
10.0	29.6																			
11.0	28.4					16.7														
12.0	26.9	25.0				16.7														
14.0	24.2	22.7				16.7														
16.0	22.0	20.8	19.4	18.4		16.7	16.7				14.8				10.4					
18.0	20.2	19.1	17.9	17.1	16.6	16.7	16.7				14.4				10.2					
20.0	18.6	17.7	16.6	16.0	15.5	16.7	15.8	14.6			14.1	13.0			10.0					
22.0	17.2	16.4	15.5	14.9	14.6	15.7	14.7	13.7			13.7	12.6			9.8					
24.0	14.2	15.3	14.5	14.0	13.7	14.5	13.7	12.8	12.2	11.8	13.4	12.2			9.6	8.8				
26.0	10.9	12.0	13.4	13.2	13.0	13.5	12.8	12.0	11.5	11.1	12.5	11.7			9.4	8.5				
28.0	8.1	9.1	10.3	11.1	11.4	11.1	12.0	11.3	10.8	10.5	11.7	11.0	10.2		9.3	8.1				
30.0	5.8	6.7	7.7	8.4	8.5	8.7	10.2	10.7	10.2	10.0	10.8	10.3	9.7		8.9	7.8				
32.0		4.6	5.5	6.0		6.7	8.0	9.7	9.7	9.5	8.7	9.7	9.1	8.7	8.6	7.6	6.5			
34.0						4.9	6.1	7.6	8.8	9.1	6.9	8.6	8.6	8.3	8.1	8.2	7.3	6.3		
36.0							4.4	5.8	6.8	7.2	5.3	6.9	8.2	7.9	7.7	7.3	7.0	6.2	5.6	
38.0								4.2	5.0	5.2	3.9	5.3	7.2	7.5	7.3	5.9	6.8	6.0	5.5	
40.0									3.4			4.0	5.7	7.0	6.9	4.6	6.2	5.8	5.4	5.1
42.0												4.3	5.5		3.4	5.0	5.7	5.2	5.1	
44.0													4.1			3.8	5.5	5.1	5.0	
46.0																2.8	4.5	5.0	4.9	
48.0																	3.5	4.7	4.9	
50.0																		3.6		
θ(°)	60~84.5	59~84.5	61~84.5	62~84.5	65~84.5		62~84.5	61~84.5	65~84.5	61~84.5	63~84.5	65~84.5	66~84.5	72~84.5	61~84.5	62~84.5	66~84.5	67~84.5	72~84.5	
標準フック	80t										25t					11.3t				
フック質量	1270kg										870kg					440kg				
標準巻掛本数	4										2					1				

注)カウンタウエイト 78t、アウトリガ張出幅 6.8m
 または、カウンタウエイト 58t、アウトリガ張出幅 8.5m
 または、カウンタウエイト 58t、アウトリガ張出幅 8.0m

■FF性能

50. 5mブーム+1. 6m+フルオートラフingジブ

単位:t

ジブ長さ(m)	10.3m					17.2m					24.1m					31.0m				
	オフセット					オフセット					オフセット					オフセット				
	5°	15°	30°	45°	60°	5°	15°	30°	45°	60°	5°	15°	30°	45°	60°	5°	15°	30°	45°	60°
11.0	20.8																			
12.0	19.8																			
14.0	18.0	16.3				15.8														
16.0	16.5	15.1	13.5			14.4	12.8				12.8									
18.0	15.0	14.0	12.7	11.8	11.2	13.3	11.9				11.8				9.1					
20.0	13.7	13.0	11.9	11.1	10.6	12.3	11.1				10.9	9.7			9.1					
22.0	12.6	12.1	11.2	10.5	10.1	11.4	10.4	9.2			10.1	9.0			9.1					
24.0	11.6	11.1	10.5	10.0	9.6	10.7	9.7	8.7	8.0		9.5	8.5			8.8					
26.0	10.7	10.3	9.9	9.5	9.2	10.0	9.1	8.2	7.6	7.2	8.8	8.0	7.0		8.2	7.4				
28.0	8.4	9.4	9.2	9.0	8.8	9.3	8.6	7.8	7.3	6.9	8.3	7.5	6.7		7.7	6.9				
30.0	6.1	7.0	8.1	8.2	8.0	8.6	8.2	7.4	6.9	6.6	7.8	7.1	6.3		7.3	6.5				
32.0			5.9	6.5	6.7	6.8	7.6	7.0	6.6	6.4	7.4	6.7	6.0	5.5	6.8	6.2	5.5			
34.0						5.0	6.2	6.6	6.3	6.1	6.8	6.4	5.7	5.3	6.5	5.9	5.2			
36.0							4.6	6.0	5.9	5.7	5.3	6.0	5.4	5.1	4.8	6.1	5.5	5.0		
38.0								4.4	5.3	5.2		5.4	5.2	4.8	4.5	5.7	5.3	4.7	4.3	
40.0													4.8	4.5	4.3	4.5	5.0	4.4	4.0	
42.0													4.3	4.2	4.0		4.6	4.2	3.8	3.5
44.0														3.9			3.8	3.9	3.5	3.3
46.0																		3.6	3.3	3.1
48.0																		3.4	3.1	2.9
50.0																			2.9	
θ(°)	63~84.5	65~84.5	64~84.5	65~84.5	66~84.5	63~84.5	64~84.5	65~84.5	67~84.5	68~84.5	65~84.5	67~84.5	68~84.5	72~84.5	65~84.5	67~84.5	68~84.5	70~84.5	75~84.5	
標準フック											25t					11.3t				
フック質量											870kg					440kg				
標準巻掛本数											2					1				

注)カウンタウエイト 78t、アウトリガ張出幅 6.8m
 または、カウンタウエイト 58t、アウトリガ張出幅 8.5m
 または、カウンタウエイト 58t、アウトリガ張出幅 8.0m

■FF性能

55. 6mブーム+1. 6m+フルオートラフingジブ

単位:t

ジブ長さ(m)	10.3m					17.2m					24.1m					31.0m					
	オフセット					オフセット					オフセット					オフセット					
	5°	15°	30°	45°	60°	5°	15°	30°	45°	60°	5°	15°	30°	45°	60°	5°	15°	30°	45°	60°	
12.0	14.6																				
14.0	14.6	13.7																			
16.0	13.4	12.5				12.0															
18.0	12.3	11.5	10.6	10.0		11.0	10.0				9.4										
20.0	11.2	10.6	9.8	9.3	8.9	10.0	9.2				9.4				6.4						
22.0	10.3	9.8	9.1	8.6	8.4	9.2	8.5	7.8			8.7	8.0			6.4						
24.0	9.6	9.0	8.5	8.1	7.8	8.5	7.9	7.2			8.1	7.4			6.4						
26.0	8.6	8.4	7.9	7.6	7.4	7.9	7.4	6.8	6.4		7.5	6.9			6.4	6.3					
28.0	7.6	7.5	7.3	7.1	6.9	7.3	6.9	6.3	6.0	5.7	6.9	6.4	5.8		6.4	5.9					
30.0	6.6	6.5	6.4	6.3	6.2	6.6	6.4	5.9	5.5	5.3	6.5	6.0	5.5		6.0	5.5					
32.0		5.5	5.6	5.6	5.5	5.8	5.7	5.4	5.1	4.9	6.0	5.6	5.1		5.6	5.2					
34.0				4.8	4.8			5.0	4.9	4.6	4.4	5.4	5.1	4.7	4.4		5.1	4.7	4.3		
36.0								4.4	4.2	4.1	4.7	4.6	4.2	4.0	3.8	4.6	4.3	3.9			
38.0									3.8	3.7	4.2	4.2	3.9	3.6	3.5	4.2	3.9	3.6			
40.0												3.7	3.5	3.3	3.2	3.8	3.5	3.3	3.1		
42.0														3.2	3.0	2.9	3.2	2.9	2.8		
44.0															2.7	2.6			2.7	2.5	2.4
46.0																			2.4	2.3	2.2
48.0																				2.0	1.9
50.0																					1.8
θ(°)	66~84.5	65~84.5	67~84.5	66~84.5		67~84.5	68~84.5	69~84.5	70~84.5		66~84.5	68~84.5	70~84.5	71~84.5	73~84.5	69~84.5	70~84.5	72~84.5	73~84.5	77~84.5	
標準フック	25t										11.3t										
フック質量	870kg										440kg										
標準巻掛本数	2										1										

注)カウンタウエイト 78t、アウトリガ張出幅 6.8m

または、カウンタウエイト 58t、アウトリガ張出幅 8.5m

または、カウンタウエイト 58t、アウトリガ張出幅 8.0m

■FF性能

60. 0mブーム+1. 6m+フルオートラフingジブ

単位:t

ジブ長さ(m)	10.3m					17.2m					24.1m					31.0m					
	オフセット					オフセット					オフセット					オフセット					
	5°	15°	30°	45°	60°	5°	15°	30°	45°	60°	5°	15°	30°	45°	60°	5°	15°	30°	45°		
14.0	12.0																				
16.0	11.7	11.0				8.0															
18.0	10.7	10.0	9.3			8.0					7.1										
20.0	9.7	9.2	8.6	8.2		8.0	8.0				7.1										
22.0	8.9	8.5	7.9	7.6	7.3	8.0	7.8				7.1				5.7						
24.0	8.2	7.8	7.4	7.1	6.9	7.7	7.2	6.6			7.1	6.6			5.7						
26.0	7.1	7.1	6.8	6.6	6.4	7.1	6.7	6.2			6.6	6.1			5.7						
28.0	6.2	6.1	6.1	6.0	5.8	6.5	6.2	5.8	5.5		6.1	5.7			5.7	5.3					
30.0		5.3	5.2	5.2	5.1	5.7	5.7	5.3	5.0	4.8	5.7	5.3	4.9		5.3	5.0					
32.0			4.5	4.5	4.4	4.9	5.0	4.8	4.5	4.3	5.1	4.8	4.4		4.8	4.5					
34.0							4.3	4.3	4.1	3.9	4.4	4.3	4.0	3.8		4.3	4.1				
36.0								3.8	3.7	3.5	3.8	3.8	3.6	3.4		3.9	3.7	3.4			
38.0									3.3	3.2		3.4	3.2	3.1	2.9	3.5	3.3	3.1			
40.0										2.7			2.9	2.7	2.6		2.9	2.7			
42.0														2.4	2.3				2.4	2.3	
44.0														2.2	2.1				2.2	2.1	
46.0																				1.8	
48.0																					1.6
θ(°)	70~84.5	69~84.5	70~84.5	71~84.5	70~84.5	71~84.5	72~84.5	71~84.5	70~84.5	71~84.5	73~84.5	75~84.5	72~84.5	73~84.5	75~84.5	72~84.5	73~84.5	75~84.5	76~84.5		
標準フック	25t										11.3t										
フック質量	870kg										440kg										
標準巻掛本数	2										1										

注)カウンタウエイト 78t、アウトリガ張出幅 6.8m

または、カウンタウエイト 58t、アウトリガ張出幅 8.5m

または、カウンタウエイト 58t、アウトリガ張出幅 8.0m

■FG性能

40. 4mブーム+1.6m+フルオートラフィングジブ

単位:t

ジブ長さ(m)	10.3m					17.2m					24.1m					31.0m																		
	オフセット					オフセット					オフセット					オフセット																		
作業半径(m)	5°	15°	30°	45°	60°	5°	15°	30°	45°	60°	5°	15°	30°	45°	60°	5°	15°	30°	45°	60°														
9.0	39.9																																	
10.0	37.4					16.7																												
11.0	35.2	33.2				16.7																												
12.0	33.3	31.5				16.7																												
14.0	29.9	28.4	26.8			16.7	16.7				16.1																							
16.0	27.0	25.9	24.5	23.6	22.7	16.7	16.7				15.6					10.9																		
18.0	22.6	23.7	22.6	21.8	21.3	16.7	16.7	16.7			15.2	13.8				10.8																		
20.0	17.7	19.0	20.6	20.2	19.8	16.7	16.7	16.7			14.7	13.3				10.6																		
22.0	13.4	14.7	16.4	17.4	17.9	16.6	16.7	16.7	14.4		14.2	12.8				10.3	9.4																	
24.0	9.9	11.1	12.6	13.6	14.1	13.2	15.0	16.2	14.0	12.9	13.7	12.4				10.1	9.0																	
26.0	7.1	8.1	9.4	10.2	10.6	10.2	12.0	14.1	13.7	12.7	12.5	12.0	10.8			9.8	8.6																	
28.0		5.6	6.7	7.4	7.6	7.8	9.3	11.4	12.8	12.5	10.0	11.7	10.4			9.4	8.3																	
30.0				5.0		5.7	7.1	8.9	10.3	11.1	7.9	9.8	10.1	9.3		9.0	7.9	6.9																
32.0						3.9	5.1	6.8	8.0	8.5	6.1	7.8	9.8	9.1	8.4	8.1	7.6	6.6																
34.0								4.9	5.9	6.3	4.5	6.0	8.2	8.9	8.2	6.5	7.4	6.4																
36.0									4.1			4.5	6.4	8.0	8.1	5.1	6.9	6.2	5.7															
38.0													4.9	6.3	7.0	3.8	5.5	6.0	5.5															
40.0														4.7			4.2	5.9	5.4	5.1														
42.0																	3.1	5.0	5.3	5.1														
44.0																		3.8	5.2	5.0														
46.0																			4.0	4.8														
48.0																				2.9														
θ(°)	61~84.5		63~84.5		61~84.5		64~84.5		61~84.5		63~84.5		66~84.5		62~84.5		64~84.5		67~84.5		68~84.5		73~84.5		62~84.5		63~84.5		67~84.5		66~84.5		72~84.5	
標準フック	80t										25t					11.3t																		
フック質量	1270kg										870kg					440kg																		
標準巻掛本数	4										2					1																		

注)カウンタウエイト 58t、アウトリガ張出幅 6.8m
 または、カウンタウエイト 47t、アウトリガ張出幅 8.5m
 または、カウンタウエイト 47t、アウトリガ張出幅 8.0m

■FG性能

45. 4mブーム+1.6m+フルオートラフィングジブ

単位:t

ジブ長さ(m)	10.3m					17.2m					24.1m					31.0m														
	オフセット					オフセット					オフセット					オフセット														
作業半径(m)	5°	15°	30°	45°	60°	5°	15°	30°	45°	60°	5°	15°	30°	45°	60°	5°	15°	30°	45°	60°										
10.0	29.6																													
11.0	28.4					16.7																								
12.0	26.9	25.0				16.7																								
14.0	24.2	22.7				16.7																								
16.0	22.0	20.8	19.4	18.4		16.7	16.7				14.8					10.4														
18.0	20.2	19.1	17.9	17.1	16.6	16.7	16.7				14.4					10.2														
20.0	17.7	17.7	16.6	16.0	15.5	16.7	15.8	14.6			14.1	13.0				10.0														
22.0	13.4	14.8	15.5	14.9	14.6	15.7	14.7	13.7			13.7	12.6				9.8														
24.0	10.0	11.2	12.7	13.8	13.7	13.0	13.7	12.8	12.2	11.8	13.4	12.2				9.6	8.8													
26.0	7.1	8.2	9.5	10.5	10.9	10.1	11.9	12.0	11.5	11.1	12.2	11.7				9.4	8.5													
28.0			6.9	7.6	7.9	7.6	9.2	11.3	10.8	10.5	9.7	11.0	10.2			9.3	8.1													
30.0						5.6	7.0	8.9	10.2	10.0	7.6	9.6	9.7			8.9	7.8													
32.0							5.1	6.8	8.1	8.8	5.8	7.6	9.1	8.7		7.8	7.6	6.5												
34.0								4.9	6.0	6.6		5.8	8.1	8.3	8.1	6.2	7.3	6.3												
36.0										4.6			6.4	7.9	7.7	4.8	6.6	6.2	5.6											
38.0													4.8	6.3	7.2		5.2	6.0	5.5											
40.0														4.7	5.5		4.0	5.8	5.4	5.1										
42.0																		4.9	5.2	5.1										
44.0																		3.7	5.1	5.0										
46.0																			4.0	4.9										
θ(°)	65~84.5		66~84.5		68~84.5		66~84.5		67~84.5		69~84.5		67~84.5		66~84.5		68~84.5		70~84.5		72~84.5		66~84.5		68~84.5		70~84.5		74~84.5	
標準フック	80t										25t					11.3t														
フック質量	1270kg										870kg					440kg														
標準巻掛本数	4										2					1														

注)カウンタウエイト 58t、アウトリガ張出幅 6.8m
 または、カウンタウエイト 47t、アウトリガ張出幅 8.5m
 または、カウンタウエイト 47t、アウトリガ張出幅 8.0m

■FG性能

50. 5mブーム+1. 6m+フルオートラフィングジブ

単位:t

ジブ長さ(m)	10.3m					17.2m					24.1m					31.0m				
	オフセット					オフセット					オフセット					オフセット				
	5°	15°	30°	45°	60°	5°	15°	30°	45°	60°	5°	15°	30°	45°	60°	5°	15°	30°	45°	60°
11.0	20.8																			
12.0	19.8																			
14.0	18.0	16.3				15.8														
16.0	16.5	15.1	13.5			14.4	12.8				12.8									
18.0	15.0	14.0	12.7	11.8	11.2	13.3	11.9				11.8					9.1				
20.0	13.7	13.0	11.9	11.1	10.6	12.3	11.1				10.9	9.7				9.1				
22.0	12.6	12.1	11.2	10.5	10.1	11.4	10.4	9.2			10.1	9.0				9.1				
24.0	10.3	11.1	10.5	10.0	9.6	10.7	9.7	8.7	8.0		9.5	8.5				8.8				
26.0	7.4	8.5	9.9	9.5	9.2	10.0	9.1	8.2	7.6	7.2	8.8	8.0	7.0			8.2	7.4			
28.0			7.2	8.1	8.4	7.8	8.6	7.8	7.3	6.9	8.3	7.5	6.7			7.7	6.9			
30.0							7.2	7.4	6.9	6.6	7.6	7.1	6.3			7.3	6.5			
32.0								7.0	6.6	6.4		6.7	6.0	5.5		6.8	6.2	5.5		
34.0									6.3	6.1		5.9	5.7	5.3	5.0	6.1	5.9	5.2		
36.0													5.4	5.1	4.8	4.7	5.5	5.0		
38.0														4.8	4.5		5.2	4.7	4.3	
40.0															4.3		4.4	4.0		
42.0																	4.2	3.8	3.5	
44.0																		3.5	3.3	
46.0																			3.3	3.1
θ(°)	67~84.5	69~84.5	70~84.5			69~84.5	71~84.5	72~84.5			70~84.5	73~84.5	74~84.5			68~84.5	71~84.5	73~84.5	74~84.5	77~84.5
標準フック	25t															11.3t				
フック質量	870kg															440kg				
標準巻掛本数	2															1				

注)カウンタウエイト 58t、アウトリガ張出幅 6.8m

または、カウンタウエイト 47t、アウトリガ張出幅 8.5m

または、カウンタウエイト 47t、アウトリガ張出幅 8.0m

■FG性能

55. 6mブーム+1. 6m+フルオートラフィングジブ

単位:t

ジブ長さ(m)	10.3m					17.2m					24.1m					31.0m				
	オフセット					オフセット					オフセット					オフセット				
	5°	15°	30°	45°	60°	5°	15°	30°	45°	60°	5°	15°	30°	45°	60°	5°	15°	30°	45°	
12.0	14.6																			
14.0	14.6	13.7																		
16.0	13.4	12.5				12.0														
18.0	12.3	11.5	10.6	10.0		11.0	10.0				9.4									
20.0	11.2	10.6	9.8	9.3	8.9	10.0	9.2				9.4					6.4				
22.0	10.3	9.8	9.1	8.6	8.4	9.2	8.5	7.8			8.7	8.0				6.4				
24.0	9.6	9.0	8.5	8.1	7.8	8.5	7.9	7.2			8.1	7.4				6.4				
26.0	8.0	8.4	7.9	7.6	7.4	7.9	7.4	6.8	6.4		7.5	6.9				6.4	6.3			
28.0			7.3	7.1	6.9	7.3	6.9	6.3	6.0	5.7	6.9	6.4	5.8			6.4	5.9			
30.0					6.2		6.4	5.9	5.5	5.3	6.5	6.0	5.5			6.0	5.5			
32.0								5.4	5.1	4.9	6.0	5.6	5.1			5.6	5.2			
34.0									4.6	4.4		5.1	4.7	4.4		5.1	4.7	4.3		
36.0													4.2	4.0	3.8		4.3	3.9		
38.0													3.9	3.6	3.5			3.6		
40.0														3.3	3.2			3.3	3.1	
42.0																		2.9	2.8	
44.0																			2.5	
θ(°)	69~84.5	71~84.5	72~84.5	71~84.5	71~84.5	72~84.5	73~84.5	74~84.5			71~84.5	73~84.5	75~84.5	77~84.5		73~84.5	75~84.5	78~84.5		
標準フック	25t															11.3t				
フック質量	870kg															440kg				
標準巻掛本数	2															1				

注)カウンタウエイト 58t、アウトリガ張出幅 6.8m

または、カウンタウエイト 47t、アウトリガ張出幅 8.5m

または、カウンタウエイト 47t、アウトリガ張出幅 8.0m

■FG性能

60. 0mブーム+1. 6m+フルオートラフィングジブ

単位:t

ジブ長さ(m)	10.3m					17.2m					24.1m					31.0m						
	オフセット					オフセット					オフセット					オフセット						
	5°	15°	30°	45°	60°	5°	15°	30°	45°	60°	5°	15°	30°	45°	60°	5°	15°	30°				
14.0	12.0																					
16.0	11.7	11.0				8.0																
18.0	10.7	10.0	9.3			8.0					7.1											
20.0	9.7	9.2	8.6	8.2		8.0	8.0				7.1											
22.0	8.9	8.5	7.9	7.6	7.3	8.0	7.8				7.1					5.7						
24.0	8.2	7.8	7.4	7.1	6.9	7.7	7.2	6.6			7.1	6.6				5.7						
26.0		7.1	6.8	6.6	6.4	7.1	6.7	6.2			6.6	6.1				5.7						
28.0				6.0	5.8	6.5	6.2	5.8	5.5		6.1	5.7				5.7	5.3					
30.0							5.7	5.3	5.0	4.8	5.7	5.3	4.9			5.3	5.0					
32.0								4.8	4.5	4.3		4.8	4.4			4.8	4.5					
34.0									4.1	3.9			4.0	3.8			4.1					
36.0													3.6	3.4			3.7	3.4				
38.0														3.1				3.1				
40.0																		2.7				
θ(°)	73~84.5		75~84.5		74~84.5		75~84.5		77~84.5		74~84.5		75~84.5		76~84.5		78~84.5		76~84.5		78~84.5	
標準フック	25t										11.3t											
フック質量	870kg										440kg											
標準巻掛本数	2										1											

注)カウンタウエイト 58t、アウトリガ張出幅 6.8m

または、カウンタウエイト 47t、アウトリガ張出幅 8.5m

または、カウンタウエイト 47t、アウトリガ張出幅 8.0m

■FH性能

40. 4mブーム+1. 6m+フルオートラフィングジブ

単位:t

ジブ長さ(m)	10.3m					17.2m					24.1m					31.0m														
	オフセット					オフセット					オフセット					オフセット														
	5°	15°	30°	45°	60°	5°	15°	30°	45°	60°	5°	15°	30°	45°	60°	5°	15°	30°	45°	60°										
9.0	39.9																													
10.0	37.4					16.7																								
11.0	35.2	33.2				16.7																								
12.0	33.3	31.5				16.7																								
14.0	29.9	28.4	26.8			16.7	16.7				16.1																			
16.0	23.6	25.3	24.5	23.6	22.7	16.7	16.7				15.6					10.9														
18.0	18.0	19.4	21.3	21.8	21.3	16.7	16.7	16.7			15.2	13.8				10.8														
20.0	13.1	14.7	16.5	17.7	18.4	16.4	16.7	16.7			14.7	13.3				10.6														
22.0	9.3	10.7	12.4	13.7	14.3	12.7	14.7	16.7	14.4		14.2	12.8				10.3	9.4													
24.0	6.3	7.5	8.9	10.0	10.5	9.5	11.5	13.8	14.0	12.9	11.9	12.4				10.1	9.0													
26.0			6.1	6.9	7.2	6.9	8.7	11.0	12.6	12.7	9.2	11.5	10.8			9.8	8.6													
28.0							6.3	8.3	9.9	10.9	7.0	9.1	10.4			9.1	8.3													
30.0								6.1	7.5	8.2	5.1	7.0	9.6	9.3		7.2	7.9	6.9												
32.0									5.3	5.9		5.2	7.5	9.1	8.4	5.5	7.6	6.6												
34.0												5.7	7.5	8.2	4.1	6.0	6.4													
36.0													5.7	6.7		4.6	6.2	5.7												
38.0														4.9			5.6	5.5												
40.0																4.3	5.4	5.1												
42.0																	4.7	5.1												
44.0																		4.4												
θ(°)	64~84.5		66~84.5		67~84.5		67~84.5		68~84.5		69~84.5		66~84.5		68~84.5		71~84.5		73~84.5		66~84.5		69~84.5		71~84.5		73~84.5		74~84.5	
標準フック	80t										25t					11.3t														
フック質量	1270kg										870kg					440kg														
標準巻掛本数	4										2					1														

注)カウンタウエイト 47t、アウトリガ張出幅 6.8m

■FH性能

45. 4mブーム+1.6m+フルオートラフィングジブ

単位:t

ジブ長さ(m)	10.3m					17.2m					24.1m				31.0m				
	オフセット					オフセット					オフセット				オフセット				
	5°	15°	30°	45°	60°	5°	15°	30°	45°	60°	5°	15°	30°	45°	5°	15°	30°	45°	60°
10.0	29.6																		
11.0	28.4					16.7													
12.0	26.9	25.0				16.7													
14.0	24.2	22.7				16.7													
16.0	22.0	20.8	19.4	18.4		16.7	16.7				14.8				10.4				
18.0	18.0	19.1	17.9	17.1	16.6	16.7	16.7				14.4				10.2				
20.0	13.2	14.7	16.6	16.0	15.5	16.3	15.8	14.6			14.1	13.0			10.0				
22.0	9.4	10.8	12.5	13.9	14.5	12.5	14.7	13.7			13.7	12.6			9.8				
24.0			9.1	10.2	10.8	9.4	11.4	12.8	12.2	11.8	11.6	12.2			9.6	8.8			
26.0				7.1	7.6	6.8	8.6	11.0	11.5	11.1	8.9	11.3			9.4	8.5			
28.0							6.2	8.3	10.0	10.5	6.7	8.9	10.2		8.8	8.1			
30.0								6.1	7.6		8.4	9.5		6.9	7.8				
32.0										6.1		7.4	8.7	5.2	7.4	6.5			
34.0												5.6	7.5		5.8	6.3			
36.0													5.7			6.2	5.6		
38.0																5.5	5.5		
40.0																		5.4	5.1
42.0																		4.7	5.1
44.0																			4.4
θ(°)	69~84.5	71~84.5	70~84.5	71~84.5	70~84.5	71~84.5	73~84.5	72~84.5	70~84.5	72~84.5	73~84.5	75~84.5	70~84.5	73~84.5	75~84.5	76~84.5			
標準フック	80t					25t									11.3t				
フック質量	1270kg					870kg									440kg				
標準巻掛本数	4					2									1				

注)カウンタウエイト 47t、アウトリガ張出幅 6.8m

■FH性能

50. 5mブーム+1.6m+フルオートラフィングジブ

単位:t

ジブ長さ(m)	10.3m					17.2m					24.1m			31.0m					
	オフセット					オフセット					オフセット			オフセット					
	5°	15°	30°	45°	60°	5°	15°	30°	45°	60°	5°	15°	30°	5°	15°	30°			
11.0	20.8																		
12.0	19.8																		
14.0	18.0	16.3				15.8													
16.0	16.5	15.1	13.5			14.4	12.8				12.8								
18.0	15.0	14.0	12.7	11.8	11.2	13.3	11.9				11.8			9.1					
20.0	13.5	13.0	11.9	11.1	10.6	12.3	11.1				10.9	9.7		9.1					
22.0	9.7	11.1	11.2	10.5	10.1	11.4	10.4	9.2			10.1	9.0		9.1					
24.0			9.4	10.0	9.6	9.5	9.7	8.7	8.0		9.5	8.5		8.8					
26.0					8.0		8.7	8.2	7.6	7.2	8.8	8.0	7.0	8.2	7.4				
28.0								7.8	7.3	6.9		7.5	6.7	7.7	6.9				
30.0									6.9	6.6			6.3	6.8	6.5				
32.0										6.4			6.0		6.2	5.5			
34.0															5.7	5.2			
36.0																5.0			
38.0																			4.7
θ(°)	71~84.5	73~84.5	74~84.5	73~84.5	72~84.5	73~84.5	75~84.5	74~84.5	73~84.5	75~84.5	76~84.5	73~84.5	75~84.5	77~84.5					
標準フック						25t								11.3t					
フック質量						870kg								440kg					
標準巻掛本数						2								1					

注)カウンタウエイト 47t、アウトリガ張出幅 6.8m

■FH性能

55. 6mブーム+1.6m+フルオートラフィングジブ

単位:t

ジブ長さ(m)	10.3m					17.2m				24.1m			31.0m	
	オフセット					オフセット				オフセット			オフセット	
	5°	15°	30°	45°	60°	5°	15°	30°	45°	5°	15°	30°	5°	15°
12.0	14.6													
14.0	14.6	13.7												
16.0	13.4	12.5				12.0								
18.0	12.3	11.5	10.6	10.0		11.0	10.0			9.4				
20.0	11.2	10.6	9.8	9.3	8.9	10.0	9.2			9.4			6.4	
22.0	10.3	9.8	9.1	8.6	8.4	9.2	8.5	7.8		8.7	8.0		6.4	
24.0			8.5	8.1	7.8	8.5	7.9	7.2		8.1	7.4		6.4	
26.0				7.6	7.4		7.4	6.8	6.4	7.5	6.9		6.4	6.3
28.0								6.3	6.0		6.4	5.8	6.4	5.9
30.0									5.5		6.0	5.5		5.5
32.0												5.1		5.2
θ(°)	73~84.5	75~84.5	74~84.5	75~84.5	74~84.5	75~84.5	76~84.5	77~84.5		76~84.5	78~84.5	77~84.5	78~84.5	
標準フック						25t							11.3t	
フック質量						870kg							440kg	
標準巻掛本数						2							1	

注)カウンタウエイト 47t、アウトリガ張出幅 6.8m

■FH性能

60. 0mブーム+1. 6m+フルオートラフィングジブ

単位:t

ジブ長さ(m)	10.3m				17.2m			24.1m		31.0m
作業半径(m)	オフセット				オフセット			オフセット		オフセット
	5°	15°	30°	45°	5°	15°	30°	5°	15°	5°
14.0	12.0									
16.0	11.7	11.0			8.0					
18.0	10.7	10.0	9.3		8.0			7.1		
20.0	9.7	9.2	8.6	8.2	8.0	8.0		7.1		
22.0		8.5	7.9	7.6	8.0	7.8		7.1		5.7
24.0				7.1	7.7	7.2	6.6	7.1	6.6	5.7
26.0						6.7	6.2	6.6	6.1	5.7
28.0							5.8			5.7
θ(°)	77~84.5	76~84.5	78~84.5		77~84.5	78~84.5	77~84.5	78~84.5	79~84.5	
標準フック	25t				11.3t					
フック質量	870kg				440kg					
標準巻掛本数	2				1					

注)カウンタウエイト 47t、アウトリガ張出幅 6.8m

■FI性能

40. 4mブーム+1. 6m+フルオートラフィングジブ

単位:t

ジブ長さ(m)	10.3m					17.2m					24.1m			31.0m		
作業半径(m)	オフセット					オフセット					オフセット			オフセット		
	5°	15°	30°	45°	60°	5°	15°	30°	45°	60°	5°	15°	30°	5°	15°	30°
9.0	39.9															
10.0	37.4					16.7										
11.0	35.2	33.2				16.7										
12.0	33.3	31.5				16.7										
14.0	25.6	27.8	26.8			16.7	16.7				16.1					
16.0	18.4	20.2	22.6	23.6	22.7	16.7	16.7				15.6			10.9		
18.0	12.8	14.7	16.7	18.3	19.2	16.3	16.7	16.7			15.2	13.8		10.8		
20.0		10.1	12.2	13.6	14.3	12.1	14.4	16.7			14.3	13.3		10.6		
22.0				9.5	10.2	8.5	10.8	13.4	14.4		11.0	12.8		10.3	9.4	
24.0							7.7	10.4	12.2	12.9	8.1	10.7		10.1	9.0	
26.0								7.5	9.4	10.4		8.1	10.8	8.0	8.6	
28.0									6.7	7.7			8.8		8.3	
30.0													6.6		6.6	6.9
32.0																6.6
34.0																6.2
θ(°)	71~84.5	73~84.5	72~84.5	73~84.5	72~84.5	73~84.5	74~84.5	72~84.5	73~84.5	74~84.5	72~84.5	74~84.5	76~84.5	73~84.5	74~84.5	77~84.5
標準フック	80t					25t					11.3t					
フック質量	1270kg					870kg					440kg					
標準巻掛本数	4					2					1					

注)カウンタウエイト 25t、アウトリガ張出幅 8.5m

または、カウンタウエイト 25t、アウトリガ張出幅 8.0m

■FI性能

45. 4mブーム+1. 6m+フルオートラフィングジブ

単位:t

ジブ長さ(m)	10.3m					17.2m			24.1m		31.0m	
作業半径(m)	オフセット					オフセット			オフセット		オフセット	
	5°	15°	30°	45°	60°	5°	15°	30°	5°	15°	5°	15°
10.0	29.6											
11.0	28.4					16.7						
12.0	26.9	25.0				16.7						
14.0	24.2	22.7				16.7						
16.0	18.4	20.2	19.4	18.4		16.7	16.7		14.8		10.4	
18.0	12.8	14.8	16.8	17.1	16.6	16.2	16.7		14.4		10.2	
20.0			12.3	13.7	14.5	11.9	14.3	14.6	14.1	13.0	10.0	
22.0					10.5		10.7	13.4	10.7	12.6	9.8	
24.0								10.3		10.5	9.6	8.8
26.0											7.6	8.5
28.0												8.1
θ(°)	74~84.5	75~84.5	77~84.5	76~84.5	76~84.5	77~84.5	75~84.5	77~84.5	74~84.5	78~84.5		
標準フック	80t					25t			11.3t			
フック質量	1270kg					870kg			440kg			
標準巻掛本数	4					2			1			

注)カウンタウエイト 25t、アウトリガ張出幅 8.5m

または、カウンタウエイト 25t、アウトリガ張出幅 8.0m

■FI性能

50. 5mブーム+1. 6m+フルオートラフィングジブ

単位:t

ジブ長さ(m)	10.3m			17.2m		24.1m		31.0m
作業半径(m)	オフセット			オフセット		オフセット		オフセット
	5°	15°	30°	5°	15°	5°	15°	5°
11.0	20.8							
12.0	19.8							
14.0	18.0	16.3		15.8				
16.0	16.5	15.1	13.5	14.4	12.8	12.8		
18.0		14.0	12.7	13.3	11.9	11.8		9.1
20.0			11.9	12.0	11.1	10.9		9.1
22.0					10.4		9.0	9.1
24.0							8.5	8.8
θ(°)	77~84.5			76~84.5	77~84.5	78~84.5	79~84.5	77~84.5
標準フック	25t			25t		11.3t		11.3t
フック質量	870kg			870kg		440kg		440kg
標準巻掛本数	2			2		1		1

注)カウンタウエイト 25t、アウトリガ張出幅 8.5m

または、カウンタウエイト 25t、アウトリガ張出幅 8.0m

4. ラフィングジブ定格総荷重表

1. 定格総荷重表の性能区分 LA～LGは、下表のとおりです。

カウンタウエイト アウトリガ 張出幅	138 t	118 t	98 t	78 t	58 t	47 t
8.5m	LA	LB	LD	LE	LF	LG
8.0m		LC	LD	LE	LF	LG
6.8m				LF	LG	

2. 定格総荷重は、つり具質量とフック質量（80 トフック：1,270 kg、25 トフック：870 kg）を含んだ値を示します。
3. 定格総荷重は、ブームのたわみを含んだ実際の作業半径に基づいています。
4. 各ブーム長さにおける各ブーム段の伸長状態（伸長割合%）は、下表のとおりです。

ブーム長さ	15.0m	20.1m	25.1m	30.2m	35.3m	40.4m	45.4m	50.5m	55.6m
伸縮ブーム1	0	0	45	90	90	90	90	90	90
伸縮ブーム2	0	45	45	45	90	90	90	90	90
伸縮ブーム3	0	0	0	0	0	45	90	90	90
伸縮ブーム4	0	0	0	0	0	0	0	45	90

5. 定格総荷重表中の標準巻掛本数よりも少ない本数で使用する場合

- 巻掛本数の下限は下表のとおりです。

ジブ長さ	20 m	29 m	38 m	47 m
最小巻掛本数	3本	2本		

- 最大荷重の上限は下表のとおりです。

掛数	5本	4本	3本	2本
最大荷重	54.7 t	44.2 t	33.5 t	22.5 t

6. Bピン（ブーム固定ピン）を挿入していない状態では使用できません。
7. 定格総荷重は、アウトリガを水平堅土上に設置したときの値です。
8. 定格総荷重表は、風による影響を含んでいません。瞬間最大風速が 10m/s 以上の風速では、クレーン作業を中止してください。
9. 定格総荷重表中の太線より上側はクレーンの強度に、下側はクレーンの安定に基づいています。
10. 「 θ (°)」は、無負荷状態で作動可能なジブオフセット角度範囲を示します。

オフセットは下図のように、ブームの中心線とジブの中心線とのなす角度を示します。

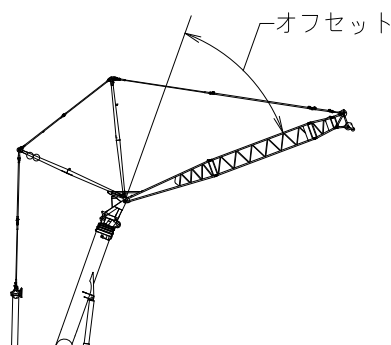

● LA性能

2.1m+20mラフィングジブ

単位:t

ブーム長さ	15.0m			20.1m			25.1m			30.2m			35.3m		
ブーム起伏角 作業半径(m)	75°	65°	55°	75°	65°	75°	65°	83°	75°	65°	83°	75°	65°		
12.0											38.8				
14.0	64.0										38.8		34.6		
16.0	64.0			53.0							38.8		34.6		
18.0	62.0			53.0				38.8			38.8		34.6		
20.0	56.0	56.2		52.9				38.8			37.5	38.8	34.6		
22.0	51.0	51.0		48.5	47.2	38.2		37.0	38.8		34.6	34.6			
24.0		46.6	45.0	44.8	43.6	37.2	38.8		37.7				33.3		
26.0		42.8	41.4		40.4	37.2	38.5		35.1				30.9		
28.0			38.3		37.5		36.1				29.8		29.8		
30.0							33.7				26.9		23.5		
32.0											25.2		22.0		
34.0													20.6		
θ(°)	5~52	5~58	5~40	5~56	5~51	5~60	5~46	5~57	5~46	5~42	5~50	5~47	5~38		
標準フック	80t			80t			80t			80t			80t		
フック質量	1270kg			1270kg			1270kg			1270kg			1270kg		
標準巻掛本数	6			5			4			4			4		

注)カウンタウエイト 138t、アウトリガ張出幅 8.5m

単位:t

ブーム長さ	40.4m		45.4m		50.5m		55.6m
ブーム起伏角 作業半径(m)	83°	75°	83°	75°	83°	75°	83°
16.0	29.2						
18.0	29.2		18.8			11.9	
20.0	29.2		18.8			11.9	7.5
22.0	29.2		18.8			11.9	7.5
24.0	29.2	29.2	18.8			11.9	7.5
26.0		27.2	18.8				7.5
28.0		25.4	18.8			11.9	
30.0		23.7	18.8			11.9	
32.0						11.9	
θ(°)	5~56	5~49	5~48	5~38	5~42	5~38	5~45
標準フック	80t		25t		25t		25t
フック質量	1270kg		870kg		870kg		870kg
標準巻掛本数	3		3		3		3

注)カウンタウエイト 138t、アウトリガ張出幅 8.5m

● LA性能

2.1m+29mラフィングジブ

単位:t

ブーム長さ	15.0m				20.1m				25.1m				30.2m				35.3m			
ブーム起伏角 作業半径(m)	83°	75°	65°	55°	83°	75°	65°	55°	83°	75°	65°	55°	83°	75°	65°	55°	83°	75°	65°	55°
10.0	47.0																			
11.0	47.0				39.5															
12.0	47.0				39.5				27.5											
14.0	47.0				39.5				27.5				27.5							
16.0	47.0	47.0			39.5				27.5				27.5							24.7
18.0	47.0	47.0			39.5	39.5			27.5				27.5							24.7
20.0	47.0	47.0			39.5	39.5			27.5	27.5			27.5							24.7
22.0	46.7	47.0			39.5	39.5			26.4	27.5			26.7	27.5						24.7
24.0	41.9	45.9	45.9		39.5	39.5			25.4	27.3			25.6	27.5						24.7
26.0	37.8	42.3	42.2		39.5	39.5	39.5		24.6	26.2			24.7	26.9						24.7
28.0	32.3	38.5	39.0		35.6	37.8	37.1		23.8	25.3			24.0	25.8						24.1
30.0		35.1	36.2	34.8		35.2	34.7		22.8	24.4	26.5		23.1	24.9						23.2
32.0		29.4	33.8	32.5		32.9	32.5			23.6	25.5			24.1	24.9					22.4
34.0			31.6	30.4		30.4	28.8			22.7	24.6				23.2	23.3				23.4
36.0				28.5		28.5	27.0				23.8				22.5	21.9				22.1
38.0							25.2				22.9	23.3			20.6					19.0
40.0							23.6					21.8			19.5					17.9
42.0												20.5				17.4				16.8
44.0																15.5				15.9
46.0																14.6				12.8
48.0																				11.4
θ(°)	5~60	5~65	5~48	5~35	5~56	5~53	5~46	5~42	5~61	5~55	5~43	5~34	5~56	5~57	5~40	5~38	5~61	5~47	5~38	5~30
標準フック	80t				80t				80t				80t				25t			
フック質量	1270kg				1270kg				1270kg				1270kg				870kg			
標準巻掛本数	5				4				3				3				3			

注)カウンタウエイト 138t、アウトリガ張出幅 8.5m

単位:t

ブーム長さ	40.4m			45.4m			50.5m			55.6m			
ブーム起伏角 作業半径(m)	83°	75°	65°	83°	75°	65°	83°	75°	65°	83°	75°	65°	
18.0	20.3												
20.0	20.3			13.4			7.7						
22.0	20.3			13.4			7.7				4.7		
24.0	20.3			13.4			7.7				4.7		
26.0	20.3			13.4			7.7				4.7		
28.0	20.3	20.3		13.4			7.7				4.7		
30.0	20.3	20.3		13.4	13.4		7.7				4.7		
32.0	20.3	20.3		13.4	13.4		7.7	7.7			4.7		
34.0		20.3		13.4	13.4		7.7	7.7			4.7	4.7	
36.0		19.1			13.4			7.7				4.7	
38.0		18.1	15.9		13.4			7.7				4.7	
40.0			14.9		13.4			7.7				4.7	
42.0							12.3					4.7	
44.0										7.7			
46.0										7.7			
48.0										7.7			
50.0										7.7			
θ(°)	5~55	5~48	5~45	5~59	5~49	5~41	5~53	5~41	5~38	5~48	5~41		
標準フック	80t			25t			25t			25t			
フック質量	1270kg			870kg			870kg			870kg			
標準巻掛本数	5			2			2			2			

注)カウンタウエイト 138t、アウトリガ張出幅 8.5m

● LA性能

2.1m+38mラフィングジブ

単位:t

ブーム長さ √ブーム起伏角 作業半径(m)	15.0m				20.1m				25.1m				30.2m				35.3m			
	83°	75°	65°	55°	83°	75°	65°	55°	83°	75°	65°	55°	83°	75°	65°	55°	83°	75°	65°	55°
12.0	35.0																			
14.0	35.0																			
16.0	35.0																			
18.0	35.0																			
20.0	35.0	35.0																		
22.0	35.0	35.0																		
24.0	35.0	35.0																		
26.0	35.0	35.0																		
28.0	35.0	35.0	35.0																	
30.0	32.5	35.0	35.0																	
32.0	30.0	33.0	33.3																	
34.0	27.2	30.3	31.1																	
36.0	24.0	28.0	29.2	28.0																
38.0		26.0	27.5	26.3																
40.0		22.7	25.9	24.7																
42.0			24.4	23.2																
44.0			22.0	21.9																
46.0				20.6																
48.0																				
50.0																				
54.0																				
58.0																				
θ(°)	5~59	5~59	5~60	5~44	5~56	5~62	5~56	5~37	5~60	5~53	5~52	5~32	5~56	5~54	5~48	5~35	5~59	5~55	5~37	5~38
標準フック	80t				80t				25t				25t							
フック質量	1270kg				1270kg				870kg				870kg							
標準巻掛本数	4				3				2				2							

注)カウンタウエイト 138t、アウトリガ張出幅 8.5m

ブーム長さ √ブーム起伏角 作業半径(m)	40.4m				45.4m				50.5m			
	83°	75°	65°	55°	83°	75°	65°	55°	83°	75°	65°	55°
20.0	13.4											
22.0	13.4											
24.0	13.4											
26.0	13.4											
28.0	13.4											
30.0	13.4	13.4										
32.0	13.4	13.4										
34.0	13.4	13.4										
36.0	13.4	13.4										
38.0	13.4	13.4										
40.0	13.4	13.4										
42.0		13.4	13.4									
44.0		13.4	13.0									
46.0		13.4	12.3									
48.0		13.4	11.6									
50.0			11.0									
54.0			9.9	7.7								
58.0				6.9								
62.0												
66.0												
θ(°)	5~55	5~56	5~42	5~25	5~57	5~48	5~33	5~27	5~53	5~48	5~37	5~28
標準フック	25t				25t							
フック質量	870kg				870kg							
標準巻掛本数	2				2							

注)カウンタウエイト 138t、アウトリガ張出幅 8.5m

● LA性能

2.1m+47mラフィングジブ

単位:t

ブーム長さ √ブーム起伏角 作業半径(m)	15.0m				20.1m				25.1m				30.2m				35.3m			
	83°	75°	65°	55°	83°	75°	65°	55°	83°	75°	65°	55°	83°	75°	65°	55°	83°	75°	65°	55°
14.0	26.0																			
16.0	26.0																			
18.0	26.0																			
20.0	26.0																			
22.0	26.0	26.0																		
24.0	24.9	26.0																		
26.0	23.5	25.2																		
28.0	22.2	23.7																		
30.0	21.1	22.4																		
32.0	20.1	21.2	22.9																	
34.0	19.2	20.2	21.6																	
36.0	18.4	19.3	20.6																	
38.0	17.7	18.5	19.6																	
40.0	17.0	17.8	18.8																	
42.0	16.5	17.1	18.0	18.9																
44.0	16.1	16.6	17.3	18.2																
46.0		16.1	16.8	17.5																
48.0		15.9	16.3	16.9																
50.0			15.9	16.4																
54.0				15.8																
58.0																				
62.0																				
66.0																				
θ(°)	5~58	5~56	5~43	5~40	5~56	5~58	5~50	5~45	5~59	5~52	5~41	5~31	5~56	5~62	5~46	5~34	5~58	5~53	5~37	5~35
標準フック	80t				25t				25t				25t							
フック質量	1270kg				870kg				870kg				870kg							
標準巻掛本数	3				2				2				2							

注)カウンタウエイト 138t、アウトリガ張出幅 8.5m

ブーム長さ √ブーム起伏角 作業半径(m)	40.4m				45.4m				50.5m			
	83°	75°	65°	55°	83°	75°	65°	55°	83°	75°	65°	
22.0	9.0											
24.0	9.0											
26.0	9.0											
28.0	9.0											
30.0	9.0											
32.0	9.0											
34.0	9.0	9.0										
36.0	9.0	9.0										
38.0	9.0	9.0										
40.0	9.0	9.0										
42.0	9.0	9.0										
44.0	9.0	9.0										
46.0	9.0	9.0										
48.0	9.0	9.0	9.0									
50.0	9.0	9.0	9.0									
54.0		9.0	9.0									
58.0			8.4									
62.0			7.6	5.7								
66.0				5.0								
70.0				4.4								
θ(°)	5~60	5~47	5~41	5~38	5~57	5~54	5~46	5~27	5~53	5~47	5~37	
標準フック	80t				25t				25t			
フック質量	1270kg				870kg				870kg			
標準巻掛本数	3				2				2			

注)カウンタウエイト 138t、アウトリガ張出幅 8.5m

● LB性能

2.1m+20mラフィングジブ

単位:t

ブーム長さ	15.0m				20.1m			25.1m			30.2m			35.3m		
ブーム起伏角 作業半径(m)	83°	75°	65°	55°	83°	75°	65°	83°	75°	65°	83°	75°	65°	83°	75°	65°
8.0	64.0															
9.0	64.0				53.0											
10.0	64.0				53.0											
11.0	64.0				53.0			38.8								
12.0	64.0				53.0			38.8			38.8					
14.0	64.0	64.0			53.0			38.8			38.8			34.6		
16.0	64.0	64.0			53.0	53.0		38.8			38.8			34.6		
18.0	58.5	61.6			53.0	53.0		38.4	38.8		38.8			34.6		
20.0	47.5	55.4	53.5		53.0	52.9		37.3	38.8		37.5	38.8		34.6		
22.0		50.3	48.6			48.5	46.8		38.2		37.0	38.8		34.6	34.6	
24.0			44.4	42.5		44.8	42.4		37.2	38.8		37.7			33.3	
26.0			40.1	38.4			38.4		37.2	36.3		35.1			30.9	
28.0				35.0			34.9			33.0			28.8		28.8	
30.0										30.2				26.9		23.5
32.0														25.2		22.0
34.0																20.6
θ(°)	5~62	5~52	5~58	5~40	5~56	5~56	5~51	5~50	5~60	5~46	5~57	5~46	5~42	5~50	5~47	5~38
標準フック	80t				80t			80t			80t			80t		
フック質量	1270kg				1270kg			1270kg			1270kg			1270kg		
標準巻掛本数	6				5			4			4			4		

注)カウンタウエイト 118t、アウトリガ張出幅 8.5m

単位:t

ブーム長さ	40.4m		45.4m		50.5m		55.6m
ブーム起伏角 作業半径(m)	83°	75°	83°	75°	83°	75°	83°
16.0	29.2						
18.0	29.2		18.8		11.9		
20.0	29.2		18.8		11.9		7.5
22.0	29.2		18.8		11.9		7.5
24.0	29.2	29.2	18.8		11.9		7.5
26.0		27.2		18.8			7.5
28.0		25.4		18.8		11.9	
30.0		23.7		18.8		11.9	
32.0						11.9	
θ(°)	5~56	5~49	5~48	5~38	5~42	5~38	5~45
標準フック	80t		25t		25t		
フック質量	1270kg		870kg		870kg		
標準巻掛本数	3		3		3		

注)カウンタウエイト 118t、アウトリガ張出幅 8.5m

● LB性能

2.1m+29mラフィングジブ

単位:t

ブーム長さ	15.0m				20.1m				25.1m				30.2m				35.3m			
ブーム起伏角 作業半径(m)	83°	75°	65°	55°	83°	75°	65°	55°	83°	75°	65°	55°	83°	75°	65°	55°	83°	75°	65°	55°
10.0	47.0																			
11.0	47.0				39.5															
12.0	47.0				39.5				27.5											
14.0	47.0				39.5				27.5				27.5							
16.0	47.0	47.0			39.5				27.5				27.5				24.7			
18.0	47.0	47.0			39.5	39.5			27.5				27.5				24.7			
20.0	47.0	47.0			39.5	39.5			27.5	27.5			27.5				24.7			
22.0	46.7	47.0			39.5	39.5			26.4	27.5			26.7	27.5			24.7			
24.0	41.9	45.3	43.6		39.5	39.5			25.4	27.3			25.6	27.5			24.7	24.7		
26.0	37.8	41.1	39.6		39.5	39.5	37.7		24.6	26.2			24.7	26.9			24.7	24.7		
28.0	32.3	37.5	36.1		35.6	36.5	34.4		23.8	25.3			24.0	25.8			24.1	24.7		
30.0		34.4	33.1	31.5		33.4	31.5		22.8	24.4	26.5		23.1	24.9			23.2	24.7		
32.0		29.4	30.5	29.0		30.9	29.0			23.6	25.5			24.1	24.9		22.4	24.5		
34.0			28.2	26.9			26.9	25.0		22.7	24.6			23.2	23.3			23.4		
36.0				25.0			25.0	23.3			23.5			22.5	21.7			22.1		
38.0								21.7			21.9	19.8			20.2					19.0
40.0								20.3				18.5			18.8	16.4				17.9
42.0												17.3				15.4				16.8
44.0																14.4				15.9
46.0																13.5				12.8
48.0																				12.1
																				11.4
θ(°)	5~60	5~65	5~48	5~35	5~56	5~53	5~46	5~42	5~61	5~55	5~43	5~34	5~56	5~57	5~40	5~38	5~61	5~47	5~38	5~30
標準フック	80t				80t				80t				80t				25t			
フック質量	1270kg				1270kg				1270kg				1270kg				870kg			
標準巻掛本数	5				4				3				3				3			

注)カウンタウエイト 118t、アウトリガ張出幅 8.5m

単位:t

ブーム長さ	40.4m			45.4m			50.5m			55.6m	
ブーム起伏角 作業半径(m)	83°	75°	65°	83°	75°	65°	83°	75°	65°	83°	75°
18.0	20.3										
20.0	20.3			13.4			7.7				
22.0	20.3			13.4			7.7			4.7	
24.0	20.3			13.4			7.7			4.7	
26.0	20.3			13.4			7.7			4.7	
28.0	20.3	20.3		13.4			7.7			4.7	
30.0	20.3	20.3		13.4	13.4		7.7			4.7	
32.0	20.3	20.3		13.4	13.4		7.7	7.7		4.7	
34.0		20.3		13.4	13.4		7.7	7.7		4.7	4.7
36.0		19.1		13.4			7.7	7.7		4.7	
38.0		18.1	15.9	13.4			7.7	7.7		4.7	
40.0			14.9	13.4			7.7	7.7		4.7	
42.0			14.0		12.3					4.7	
44.0			13.3			11.8			7.7		
46.0			12.6			11.2			7.7		
48.0						10.6			7.7		
50.0									7.7		
θ(°)	5~55	5~48	5~45	5~59	5~49	5~41	5~53	5~41	5~38	5~48	5~41
標準フック	25t										
フック質量	870kg										
標準巻掛本数	2										

注)カウンタウエイト 118t、アウトリガ張出幅 8.5m

● LB性能

2.1m+38mラフィングジブ

単位:t

ブーム長さ ブーム起伏角 作業半径(m)	15.0m				20.1m				25.1m				30.2m				35.3m			
	83°	75°	65°	55°	83°	75°	65°	55°	83°	75°	65°	55°	83°	75°	65°	55°	83°	75°	65°	55°
12.0	35.0																			
14.0	35.0				29.5				18.7											
16.0	35.0				29.5				18.7						18.5					
18.0	35.0				29.5				18.7						18.5				16.9	
20.0	35.0	35.0			29.5				18.7						18.5				16.9	
22.0	35.0	35.0			29.5	29.5			18.7						18.5				16.9	
24.0	35.0	35.0			29.5	29.5			18.7	18.7					18.5				16.9	
26.0	35.0	35.0			29.5	29.5			18.7	18.7					18.5	18.5			16.9	
28.0	35.0	35.0	35.0		29.5	29.5			18.7	18.7					18.5	18.5			16.9	16.9
30.0	32.5	34.1	32.7		29.5	29.5	29.5		18.1	18.7					18.2	18.5			16.9	16.9
32.0	30.0	31.4	30.1		29.5	29.5	28.5		17.1	18.6					17.4	18.5			16.9	16.9
34.0	27.2	29.1	27.9		28.4	28.2	26.4		16.3	17.9	18.7				16.5	18.3			16.7	16.9
36.0	24.0	27.1	25.9	24.5	25.9	26.2	24.5		15.6	17.0	18.7				15.8	17.6	18.5		15.9	16.9
38.0		25.3	24.2	22.9		24.4	22.8		15.0	16.2	18.1				15.1	16.7	18.5		15.2	16.9
40.0		22.7	22.6	21.4		22.9	21.4	19.7		15.5	17.2				15.9	18.1			14.7	16.4
42.0			21.2	20.1		21.7	20.0	18.5		14.9	16.4	16.8			15.2	17.1			15.6	16.6
44.0			19.9	18.9			18.8	17.4			15.6	15.7			14.7	16.1			15.0	14.7
46.0				17.8			17.7	16.4			15.0	14.8				15.1	12.9		14.5	13.9
48.0								15.4			14.6	13.9				14.2	12.1			13.1
50.0												13.1				13.4	11.4			12.3
54.0																10.2				8.9
58.0																				7.8
θ(°)	5~59	5~59	5~60	5~44	5~56	5~62	5~56	5~37	5~60	5~53	5~52	5~32	5~56	5~54	5~48	5~35	5~59	5~55	5~37	5~38
標準フック	80t				80t				25t				25t				25t			
フック質量	1270kg				1270kg				870kg				870kg				870kg			
標準巻掛本数	4				3				2				2				2			

注)カウンタウエイト 118t、アウトリガ張出幅 8.5m

単位:t

ブーム長さ ブーム起伏角 作業半径(m)	40.4m				45.4m				50.5m			
	83°	75°	65°	55°	83°	75°	65°	55°	83°	75°	65°	55°
20.0	13.4											
22.0	13.4				9.0							
24.0	13.4				9.0				5.2			
26.0	13.4				9.0				5.2			
28.0	13.4				9.0				5.2			
30.0	13.4	13.4			9.0				5.2			
32.0	13.4	13.4			9.0	9.0			5.2			
34.0	13.4	13.4			9.0	9.0			5.2			
36.0	13.4	13.4			9.0	9.0			5.2	5.2		
38.0	13.4	13.4			9.0	9.0			5.2	5.2		
40.0	13.4	13.4			9.0	9.0			5.2	5.2		
42.0		13.4	13.4		9.0	9.0			5.2	5.2		
44.0		13.4	13.0			9.0				5.2		
46.0		13.4	12.3			9.0	9.0			5.2		
48.0		13.4	11.6			9.0	9.0			5.2		
50.0			11.0				9.0			5.2	5.2	
54.0			9.9	7.7			8.5				5.2	
58.0				6.7				5.4			5.2	
62.0								4.6				3.6
66.0												3.0
θ(°)	5~55	5~56	5~42	5~25	5~57	5~48	5~33	5~27	5~53	5~48	5~37	5~28
標準フック	25t				25t				25t			
フック質量	870kg				870kg				870kg			
標準巻掛本数	2				2				2			

注)カウンタウエイト 118t、アウトリガ張出幅 8.5m

● LB性能

2.1m+47mラフィングジブ

単位:t

ブーム長さ ブーム起伏角 作業半径(m)	15.0m				20.1m				25.1m				30.2m				35.3m			
	83°	75°	65°	55°	83°	75°	65°	55°	83°	75°	65°	55°	83°	75°	65°	55°	83°	75°	65°	55°
14.0	26.0																			
16.0	26.0				22.4				12.9											
18.0	26.0				22.4				12.9						12.3					
20.0	26.0				22.4				12.9						12.3				11.2	
22.0	26.0	26.0			22.4				12.9						12.3				11.2	
24.0	24.9	26.0			22.4	22.4			12.9						12.3				11.2	
26.0	23.5	25.2			22.4	22.4			12.9	12.9					12.3				11.2	
28.0	22.2	23.7			22.4	22.4			12.9	12.9					12.3	12.3			11.2	
30.0	21.1	22.4			21.4	22.4			12.9	12.9					12.3	12.3			11.2	
32.0	20.1	21.2	22.9		20.4	22.0			12.9	12.9					12.3	12.3			11.2	11.2
34.0	19.2	20.2	21.6		19.4	20.9			12.9	12.9					12.3	12.3			11.2	11.2
36.0	18.4	19.3	20.6		18.6	19.9	21.7		12.5	12.9					12.3	12.3			11.2	11.2
38.0	17.7	18.5	19.6		17.9	19.0	20.6		11.9	12.9	12.9				12.0	12.3			11.2	11.2
40.0	17.0	17.8	18.8		17.2	18.2	19.7		11.3	12.4	12.9				11.4	12.3			11.2	11.2
42.0	16.5	17.1	18.0	18.9	16.7	17.5	18.8		10.7	11.8	12.9				10.8	12.1	12.3		11.0	11.2
44.0	16.1	16.6	17.3	18.2	16.2	16.9	18.1	16.8	10.2	11.2	12.5				10.3	11.5	12.3		10.4	11.2
46.0		16.1	16.8	17.3		16.4	17.2	15.8	9.8	10.7	11.9				9.9	11.0	12.3		10.0	11.2
48.0		15.9	16.3	16.3		16.0	16.3	14.9		10.2	11.3	12.6				10.4	11.9		9.6	10.7
50.0		15.9	15.4			15.8	15.4	14.0		9.8	10.8	11.9				10.0	11.3		10.2	11.2
54.0			13.8				13.7	12.5			9.9	10.8				9.3	10.3	9.6		9.4
58.0								11.3				9.9					9.5	8.6		9.3
62.0																		7.6		6.1
66.0																				5.3
θ(°)	5~58	5~56	5~43	5~40	5~56	5~58	5~50	5~45	5~59	5~52	5~41	5~31	5~56	5~62	5~46	5~34	5~58	5~53	5~37	5~35
標準フック	80t				80t				25t				25t				25t			
フック質量	1270kg				1270kg				870kg				870kg				870kg			
標準巻掛本数	3				2				2				2				2			

注)カウンタウエイト 118t、アウトリガ張出幅 8.5m

単位:t

ブーム長さ ブーム起伏角 作業半径(m)	40.4m				45.4m				50.5m		
	83°	75°	65°	55°	83°	75°	65°	55°	83°	75°	65°
22.0	9.0										
24.0	9.0				6.2						
26.0	9.0				6.2				3.6		
28.0	9.0				6.2				3.6		
30.0	9.0				6.2				3.6		
32.0	9.0				6.2				3.6		
34.0	9.0	9.0			6.2				3.6		
36.0	9.0	9.0			6.2	6.2			3.6		
38.0	9.0	9.0			6.2	6.2			3.6	3.6	
40.0	9.0	9.0			6.2	6.2			3.6	3.6	
42.0	9.0	9.0			6.2	6.2			3.6	3.6	
44.0	9.0	9.0			6.2	6.2			3.6	3.6	
46.0	9.0	9.0			6.2	6.2			3.6	3.6	
48.0	9.0	9.0	9.0		6.2	6.2			3.6	3.6	
50.0	9.0	9.0	9.0		6.2	6.2	6.2		3.6	3.6	
54.0		9.0	9.0			6.2	6.2			3.6	3.6
58.0			8.4			6.2	6.2				3.6
62.0			7.4	4.8			6.2				3.6
66.0				4.1				5.6	3.0		3.5
70.0				3.5					2.4		
θ(°)	5~60	5~47	5~41	5~38	5~57	5~54	5~46	5~27	5~53	5~47	5~37
標準フック	25t				25t				25t		
フック質量	870kg				870kg				870kg		
標準巻掛本数	2				2				2		

注)カウンタウエイト 118t、アウトリガ張出幅 8.5m

● LC性能

2.1m+20mラフイングジブ

単位:t

ブーム長さ	15.0m				20.1m				25.1m			30.2m			35.3m		
ブーム起伏角 作業半径(m)	83°	75°	65°	55°	83°	75°	65°	55°	83°	75°	65°	83°	75°	65°	83°	75°	65°
8.0	64.0																
9.0	64.0				53.0												
10.0	64.0				53.0												
11.0	64.0				53.0			38.8									
12.0	64.0				53.0			38.8			38.8						
14.0	64.0	64.0			53.0			38.8			38.8			34.6			
16.0	64.0	64.0			53.0	53.0		38.8			38.8			34.6			
18.0	58.5	60.5			53.0	53.0		38.4	38.8		38.8			34.6			
20.0	47.5	54.4	52.5		53.0	52.9		37.3	38.8		37.5	38.8		34.6			
22.0		49.3	47.6			48.2	45.8		38.2		37.0	38.8		34.6	34.6		
24.0			43.5	41.8		44.2	41.8		37.2	38.8		37.7			33.3		
26.0			39.9	38.4			38.4		37.2	36.3		35.1			30.9		
28.0				35.0			34.9			33.0			28.8				
30.0										30.2				26.9		23.5	
32.0														25.2		22.0	
34.0																20.6	
θ(°)	5~62	5~52	5~58	5~40	5~56	5~56	5~51	5~50	5~60	5~46	5~57	5~46	5~42	5~50	5~47	5~38	
標準フック	80t				80t				80t				80t				
フック質量	1270kg				1270kg				1270kg				1270kg				
標準巻掛本数	6				5				4				4				

注)カウンタウエイト 118t、アウトリガ張出幅 8.0m

単位:t

ブーム長さ	40.4m		45.4m		50.5m		55.6m
ブーム起伏角 作業半径(m)	83°	75°	83°	75°	83°	75°	83°
16.0	29.2						
18.0	29.2		18.8		11.9		
20.0	29.2		18.8		11.9	7.5	
22.0	29.2		18.8		11.9	7.5	
24.0	29.2	29.2	18.8		11.9	7.5	
26.0		27.2		18.8		7.5	
28.0		25.4		18.8		11.9	
30.0		23.7		18.8		11.9	
32.0						11.9	
θ(°)	5~56	5~49	5~48	5~38	5~42	5~38	5~45
標準フック	80t		25t		25t		
フック質量	1270kg		870kg		870kg		
標準巻掛本数	3		3		3		

注)カウンタウエイト 118t、アウトリガ張出幅 8.0m

● LC性能

2.1m+29mラフイングジブ

単位:t

ブーム長さ	15.0m				20.1m				25.1m				30.2m				35.3m			
ブーム起伏角 作業半径(m)	83°	75°	65°	55°	83°	75°	65°	55°	83°	75°	65°	55°	83°	75°	65°	55°	83°	75°	65°	55°
10.0	47.0																			
11.0	47.0				39.5															
12.0	47.0				39.5			27.5												
14.0	47.0				39.5			27.5				27.5								
16.0	47.0	47.0			39.5			27.5				27.5							24.7	
18.0	47.0	47.0			39.5	39.5		27.5				27.5							24.7	
20.0	47.0	47.0			39.5	39.5		27.5	27.5			27.5							24.7	
22.0	46.7	47.0			39.5	39.5		26.4	27.5			26.7	27.5						24.7	
24.0	41.9	44.4	42.7		39.5	39.5		25.4	27.3			25.6	27.5						24.7	24.7
26.0	37.8	40.8	39.2		39.5	39.5	37.6		24.6	26.2			24.7	26.9					24.7	24.7
28.0	32.3	37.5	36.1		35.6	36.5	34.4		23.8	25.3			24.0	25.8					24.1	24.7
30.0		34.4	33.1	31.5		33.4	31.5		22.8	24.4	26.5		23.1	24.9					23.2	24.7
32.0		29.4	30.5	29.0		30.9	29.0			23.6	25.5			24.1	24.9				22.4	24.5
34.0			28.2	26.9			26.9	25.0		22.7	24.6			23.2	23.3				23.4	
36.0				25.0			25.0	23.3			23.5			22.5	21.7				22.1	19.0
38.0								21.7			21.9	19.8			20.2					17.9
40.0								20.3				18.5			18.8					16.8
42.0												17.3								15.9
44.0																				14.4
46.0																				13.5
48.0																				11.4
θ(°)	5~60	5~65	5~48	5~35	5~56	5~53	5~46	5~42	5~61	5~55	5~43	5~34	5~56	5~57	5~40	5~38	5~61	5~47	5~38	5~30
標準フック	80t				80t				80t				25t							
フック質量	1270kg				1270kg				1270kg				870kg							
標準巻掛本数	5				4				3				3							

注)カウンタウエイト 118t、アウトリガ張出幅 8.0m

単位:t

ブーム長さ	40.4m			45.4m			50.5m			55.6m	
ブーム起伏角 作業半径(m)	83°	75°	65°	83°	75°	65°	83°	75°	65°	83°	75°
18.0	20.3										
20.0	20.3			13.4			7.7				
22.0	20.3			13.4			7.7			4.7	
24.0	20.3			13.4			7.7			4.7	
26.0	20.3			13.4			7.7			4.7	
28.0	20.3	20.3		13.4			7.7			4.7	
30.0	20.3	20.3		13.4	13.4		7.7			4.7	
32.0	20.3	20.3		13.4	13.4		7.7	7.7		4.7	
34.0		20.3		13.4	13.4		7.7	7.7		4.7	4.7
36.0		19.1		13.4			7.7	7.7			4.7
38.0		18.1	15.9	13.4			7.7	7.7			4.7
40.0			14.9	13.4			7.7	7.7			4.7
42.0			14.0			12.3					4.7
44.0			13.3			11.8			7.7		
46.0			12.6			11.2			7.7		
48.0						10.6			7.7		
50.0									7.7		
θ(°)	5~55	5~48	5~45	5~59	5~49	5~41	5~53	5~41	5~38	5~48	5~41
標準フック	25t						870kg				
フック質量	870kg						870kg				
標準巻掛本数	2						2				

注)カウンタウエイト 118t、アウトリガ張出幅 8.0m

● LC性能

2.1m+38mラフィングジブ

単位:t

ブーム長さ ブーム起伏角 作業半径(m)	15.0m				20.1m				25.1m				30.2m				35.3m			
	83°	75°	65°	55°	83°	75°	65°	55°	83°	75°	65°	55°	83°	75°	65°	55°	83°	75°	65°	55°
12.0	35.0																			
14.0	35.0																			
16.0	35.0																			
18.0	35.0																			
20.0	35.0	35.0																		
22.0	35.0	35.0																		
24.0	35.0	35.0																		
26.0	35.0	35.0																		
28.0	35.0	35.0	35.0																	
30.0	32.5	34.1	32.7																	
32.0	30.0	31.4	30.1																	
34.0	27.2	29.1	27.9																	
36.0	24.0	27.1	25.9	24.5																
38.0		25.3	24.2	22.9																
40.0		22.7	22.6	21.4																
42.0			21.2	20.1																
44.0			19.9	18.9																
46.0				17.8																
48.0																				
50.0																				
54.0																				
58.0																				
θ(°)	5~59	5~59	5~60	5~44	5~56	5~62	5~56	5~37	5~60	5~53	5~52	5~32	5~56	5~54	5~48	5~35	5~59	5~55	5~37	5~38
標準フック	80t				80t				25t				870kg				2			
フック質量	1270kg				1270kg				870kg				870kg				2			
標準巻掛本数	4				3				2				2				2			

注)カウンタウエイト 118t、アウトリガ張出幅 8.0m

ブーム長さ ブーム起伏角 作業半径(m)	40.4m				45.4m				50.5m							
	83°	75°	65°	55°	83°	75°	65°	55°	83°	75°	65°	55°				
20.0	13.4															
22.0	13.4															
24.0	13.4															
26.0	13.4															
28.0	13.4															
30.0	13.4	13.4														
32.0	13.4	13.4														
34.0	13.4	13.4														
36.0	13.4	13.4														
38.0	13.4	13.4														
40.0	13.4	13.4														
42.0		13.4	13.4													
44.0		13.4	13.0													
46.0		13.4	12.3													
48.0		13.4	11.6													
50.0			11.0													
54.0			9.9	7.3												
58.0				6.3												
62.0																
66.0																
θ(°)	5~55	5~56	5~42	5~25	5~57	5~48	5~33	5~27	5~53	5~48	5~37	5~28				
標準フック	25t				25t				870kg				2			
フック質量	870kg				870kg				870kg				870kg			
標準巻掛本数	2				2				2				2			

注)カウンタウエイト 118t、アウトリガ張出幅 8.0m

● LC性能

2.1m+47mラフィングジブ

単位:t

ブーム長さ ブーム起伏角 作業半径(m)	15.0m				20.1m				25.1m				30.2m				35.3m			
	83°	75°	65°	55°	83°	75°	65°	55°	83°	75°	65°	55°	83°	75°	65°	55°	83°	75°	65°	55°
14.0	26.0																			
16.0	26.0																			
18.0	26.0																			
20.0	26.0																			
22.0	26.0	26.0																		
24.0	24.9	26.0																		
26.0	23.5	25.2																		
28.0	22.2	23.7																		
30.0	21.1	22.4																		
32.0	20.1	21.2	22.9																	
34.0	19.2	20.2	21.6																	
36.0	18.4	19.3	20.6																	
38.0	17.7	18.5	19.6																	
40.0	17.0	17.8	18.8																	
42.0	16.5	17.1	18.0	18.9																
44.0	16.1	16.6	17.3	18.2																
46.0		16.1	16.8	17.3																
48.0			15.9	16.3																
50.0				15.9	15.4															
54.0					13.8															
58.0																				
62.0																				
66.0																				
θ(°)	5~58	5~56	5~43	5~40	5~56	5~58	5~50	5~45	5~59	5~52	5~41	5~31	5~56	5~62	5~46	5~34	5~58	5~53	5~37	5~35
標準フック	80t				80t				25t				870kg				2			
フック質量	1270kg				1270kg				870kg				870kg				2			
標準巻掛本数	3				2				2				2				2			

注)カウンタウエイト 118t、アウトリガ張出幅 8.0m

ブーム長さ ブーム起伏角 作業半径(m)	40.4m				45.4m				50.5m							
	83°	75°	65°	55°	83°	75°	65°	55°	83°	75°	65°	55°				
22.0	9.0															
24.0	9.0															
26.0	9.0															
28.0	9.0															
30.0	9.0															
32.0	9.0															
34.0	9.0	9.0														
36.0	9.0	9.0														
38.0	9.0	9.0														
40.0	9.0	9.0														
42.0	9.0	9.0														
44.0	9.0	9.0														
46.0	9.0	9.0														
48.0	9.0	9.0	9.0													
50.0	9.0	9.0	9.0													
54.0		9.0	9.0													
58.0			8.1													
62.0				7.1	4.5											
66.0					3.8											
70.0					3.2											
θ(°)	5~60	5~47	5~41	5~38	5~57	5~54	5~46	5~27	5~53	5~47	5~37					
標準フック	25t				25t				870kg				2			
フック質量	870kg				870kg				870kg				870kg			
標準巻掛本数	2				2				2				2			

注)カウンタウエイト 118t、アウトリガ張出幅 8.0m

● LD性能

2.1m+20mラフイングジブ

単位:t

ブーム長さ ブーム起伏角 作業半径(m)	15.0m				20.1m				25.1m				30.2m				35.3m		
	83°	75°	65°	55°	83°	75°	65°	55°	83°	75°	65°	55°	83°	75°	65°	55°	83°	75°	65°
8.0	64.0																		
9.0	64.0					53.0													
10.0	64.0					53.0													
11.0	64.0					53.0				38.8									
12.0	64.0					53.0				38.8				38.8					
14.0	64.0	64.0				53.0				38.8				38.8				34.6	
16.0	64.0	64.0				53.0	53.0			38.8				38.8				34.6	
18.0	58.5	57.4				53.0	53.0			38.4	38.8			38.8				34.6	
20.0	47.5	50.5	48.5			51.4	49.0			37.3	38.8			37.5	38.8			34.6	
22.0		44.7	43.0				43.4	40.8			38.2			37.0	38.8			34.6	34.6
24.0			38.5	36.6			39.3	36.6			37.2	34.2			36.1				33.3
26.0			34.7	33.1				33.0			34.1	30.9			32.6				30.9
28.0				30.1				30.0				28.1				25.9			28.5
30.0												25.7				23.7			22.1
32.0																21.7			20.3
34.0																			18.6
θ(°)	5~62	5~52	5~58	5~40	5~56	5~56	5~51	5~50	5~60	5~46	5~57	5~46	5~42	5~50	5~47	5~38			
標準フック	80t				80t				80t				80t						
フック質量	1270kg				1270kg				1270kg				1270kg						
標準巻掛本数	6				5				4				4						

注)カウンタウエイト 98t、アウトリガ張出幅 8.5m
または、カウンタウエイト 98t、アウトリガ張出幅 8.0m

単位:t

ブーム長さ ブーム起伏角 作業半径(m)	40.4m		45.4m		50.5m		55.6m
	83°	75°	83°	75°	83°	75°	83°
16.0	29.2						
18.0	29.2		18.8			11.9	
20.0	29.2		18.8			11.9	7.5
22.0	29.2		18.8			11.9	7.5
24.0	29.2	29.2	18.8			11.9	7.5
26.0		27.2		18.8			7.5
28.0		25.4		18.8		11.9	
30.0		23.7		18.8		11.9	
32.0						11.9	
θ(°)	5~56	5~49	5~48	5~38	5~42	5~38	5~45
標準フック	80t		25t		870kg		
フック質量	1270kg		870kg		870kg		
標準巻掛本数	3		3		3		

注)カウンタウエイト 98t、アウトリガ張出幅 8.5m
または、カウンタウエイト 98t、アウトリガ張出幅 8.0m

● LD性能

2.1m+29mラフイングジブ

単位:t

ブーム長さ ブーム起伏角 作業半径(m)	15.0m				20.1m				25.1m				30.2m				35.3m				
	83°	75°	65°	55°	83°	75°	65°	55°	83°	75°	65°	55°	83°	75°	65°	55°	83°	75°	65°	55°	
10.0	47.0																				
11.0	47.0					39.5															
12.0	47.0					39.5				27.5											
14.0	47.0					39.5				27.5				27.5							
16.0	47.0	47.0				39.5				27.5				27.5					24.7		
18.0	47.0	47.0				39.5	39.5			27.5				27.5					24.7		
20.0	47.0	47.0				39.5	39.5			27.5	27.5			27.5					24.7		
22.0	45.5	44.2				39.5	39.5			26.4	27.5			26.7	27.5				24.7		
24.0	40.9	39.6	37.9			39.5	38.4			25.4	27.3			25.6	27.5				24.7	24.7	
26.0	37.1	35.8	34.2			36.5	34.7	32.4		24.6	26.2			24.7	26.9				24.7	24.7	
28.0	32.3	32.6	31.2			33.3	31.6	29.4		23.8	25.3			24.0	25.8				24.1	24.7	
30.0		29.8	28.5	26.9			28.9	26.9		22.8	24.4	25.1			23.1	24.9			23.2	24.7	
32.0		27.5	26.3	24.8			26.6	24.8			23.6	23.1			23.1	24.9			22.4	23.4	
34.0			24.2	22.9				22.9	21.1			22.7	21.3			24.1	21.0			22.4	23.4
36.0				21.2				21.2	19.5				21.3			22.5	19.3			21.6	23.4
38.0								21.2	19.5			19.7			20.8	17.9			20.0	16.6	16.6
40.0								21.2	19.5			18.3			16.2	16.6				15.3	15.3
42.0								21.2	19.5			16.8			15.1	16.6				14.3	14.3
44.0								21.2	19.5						14.1	16.6				13.3	13.3
46.0								21.2	19.5							15.4				11.2	11.2
48.0								21.2	19.5											10.4	10.4
θ(°)	5~60	5~65	5~48	5~35	5~56	5~53	5~46	5~42	5~61	5~55	5~43	5~34	5~56	5~57	5~40	5~38	5~61	5~47	5~38	5~30	
標準フック	80t				80t				80t				80t				25t				
フック質量	1270kg				1270kg				1270kg				1270kg				870kg				
標準巻掛本数	5				4				3				3				3				

注)カウンタウエイト 98t、アウトリガ張出幅 8.5m
または、カウンタウエイト 98t、アウトリガ張出幅 8.0m

単位:t

ブーム長さ ブーム起伏角 作業半径(m)	40.4m		45.4m		50.5m		55.6m	
	83°	75°	83°	75°	83°	75°	83°	75°
18.0	20.3							
20.0	20.3		13.4			7.7		
22.0	20.3		13.4			7.7		4.7
24.0	20.3		13.4			7.7		4.7
26.0	20.3		13.4			7.7		4.7
28.0	20.3	20.3	13.4			7.7		4.7
30.0	20.3	20.3	13.4	13.4		7.7		4.7
32.0	20.3	20.3	13.4	13.4		7.7	7.7	4.7
34.0		20.3	13.4	13.4		7.7	7.7	4.7
36.0		19.1		13.4		7.7	7.7	4.7
38.0		17.7	14.1	13.4		7.7	7.7	4.7
40.0			13.1	13.4		7.7	7.7	4.7
42.0			12.2		11.0			4.7
44.0			11.3		10.2		7.7	
46.0			10.5		9.5		7.7	
48.0					8.8		7.7	
50.0							7.2	
θ(°)	5~55	5~48	5~45	5~59	5~49	5~41	5~38	5~48
標準フック	25t		25t		870kg		870kg	
フック質量	1270kg		870kg		870kg		870kg	
標準巻掛本数	2		2		2		2	

注)カウンタウエイト 98t、アウトリガ張出幅 8.5m
または、カウンタウエイト 98t、アウトリガ張出幅 8.0m

● LD性能

2.1m+38mラフィングジブ

単位:t

ブーム長さ ブーム起伏角 作業半径(m)	15.0m				20.1m				25.1m				30.2m				35.3m			
	83°	75°	65°	55°	83°	75°	65°	55°	83°	75°	65°	55°	83°	75°	65°	55°	83°	75°	65°	55°
12.0	35.0																			
14.0	35.0				29.5				18.7											
16.0	35.0				29.5				18.7											
18.0	35.0				29.5				18.7					18.5						
20.0	35.0	35.0			29.5				18.7					18.5					16.9	
22.0	35.0	35.0			29.5	29.5			18.7					18.5					16.9	
24.0	35.0	35.0			29.5	29.5			18.7	18.7				18.5					16.9	
26.0	35.0	35.0			29.5	29.5			18.7	18.7				18.5	18.5				16.9	
28.0	33.3	32.3	30.7		29.5	29.5			18.7	18.7				18.5	18.5				16.9	16.9
30.0	30.6	29.5	28.1		29.5	28.5	26.4		18.1	18.7				18.2	18.5				16.9	16.9
32.0	28.2	27.2	25.9		27.7	26.2	24.3		17.1	18.6				17.4	18.5				16.9	16.9
34.0	26.1	25.1	23.9		25.6	24.2	22.4		16.3	17.9				16.5	18.3				16.7	16.9
36.0	24.0	23.3	22.2	20.8	23.7	22.4	20.7		15.6	17.0	18.7			15.8	17.6	17.3			15.9	16.9
38.0		21.6	20.6	19.3		20.8	19.3		15.0	16.2	17.8			15.1	16.7	16.0			15.2	16.9
40.0		20.2	19.2	18.0		19.4	18.0	16.3		15.5	16.6			15.9	14.9				14.7	16.4
42.0			18.0	16.8		18.4	16.8	15.3		14.9	15.5	13.5		15.2	13.9				15.6	12.6
44.0			16.8	15.8			15.7	14.3			14.5	12.6		14.7	13.0				14.6	11.7
46.0				14.8			14.7	13.4			13.6	11.8			12.1	9.7			13.7	10.9
48.0								12.6			12.7	11.1			11.4	9.0				10.2
50.0												10.4			10.7	8.4				9.5
54.0																7.2				6.6
58.0																				5.7
θ(°)	5~59	5~59	5~60	5~44	5~56	5~62	5~56	5~37	5~60	5~53	5~52	5~32	5~56	5~54	5~48	5~35	5~59	5~55	5~37	5~38
標準フック	80t				80t				25t				25t				870kg			
フック質量	1270kg				1270kg								870kg							
標準巻掛本数	4				3								2							

注)カウンタウエイト 98t、アウトリガ張出幅 8.5m
または、カウンタウエイト 98t、アウトリガ張出幅 8.0m

単位:t

ブーム長さ ブーム起伏角 作業半径(m)	40.4m				45.4m			50.5m					
	83°	75°	65°	55°	83°	75°	65°	83°	75°	65°			
20.0	13.4												
22.0	13.4				9.0								
24.0	13.4				9.0			5.2					
26.0	13.4				9.0			5.2					
28.0	13.4				9.0			5.2					
30.0	13.4	13.4			9.0			5.2					
32.0	13.4	13.4			9.0	9.0		5.2					
34.0	13.4	13.4			9.0	9.0		5.2					
36.0	13.4	13.4			9.0	9.0		5.2	5.2				
38.0	13.4	13.4			9.0	9.0		5.2	5.2				
40.0	13.4	13.4			9.0	9.0		5.2	5.2				
42.0		13.4	11.4		9.0	9.0		5.2	5.2				
44.0		13.4	10.6		9.0			5.2					
46.0		13.1	9.8		9.0	8.4		5.2					
48.0		12.3	9.1		9.0	7.8		5.2					
50.0			8.5			7.2		5.2	5.2				
54.0			7.3	4.4		6.2			5.2				
58.0				3.7					4.4				
θ(°)	5~55	5~56	5~42	5~25	5~57	5~48	5~33	5~53	5~48	5~37			
標準フック	80t				25t			25t			870kg		
フック質量	1270kg				870kg			870kg					
標準巻掛本数	4				2			2					

注)カウンタウエイト 98t、アウトリガ張出幅 8.5m
または、カウンタウエイト 98t、アウトリガ張出幅 8.0m

● LD性能

2.1m+47mラフィングジブ

単位:t

ブーム長さ ブーム起伏角 作業半径(m)	15.0m				20.1m				25.1m				30.2m				35.3m				
	83°	75°	65°	55°	83°	75°	65°	55°	83°	75°	65°	55°	83°	75°	65°	55°	83°	75°	65°	55°	
14.0	26.0																				
16.0	26.0				22.4				12.9												
18.0	26.0				22.4				12.9					12.3							
20.0	26.0				22.4				12.9					12.3					11.2		
22.0	26.0	26.0			22.4				12.9					12.3					11.2		
24.0	24.9	26.0			22.4	22.4			12.9					12.3					11.2		
26.0	23.5	25.2			22.4	22.4			12.9	12.9				12.3					11.2		
28.0	22.2	23.7			22.4	22.4			12.9	12.9				12.3	12.3				11.2		
30.0	21.1	22.4			21.4	22.4			12.9	12.9				12.3	12.3				11.2		
32.0	20.1	21.2	22.9		20.4	22.0			12.9	12.9				12.3	12.3				11.2	11.2	
34.0	19.2	20.2	21.6		19.4	20.9			12.9	12.9				12.3	12.3				11.2	11.2	
36.0	18.4	19.3	20.6		18.6	19.9	20.2		12.5	12.9				12.3	12.3				11.2	11.2	
38.0	17.7	18.5	19.6		17.9	19.0	18.8		11.9	12.9	12.9			12.0	12.3				11.2	11.2	
40.0	17.0	17.8	18.8		17.2	18.2	17.5		11.3	12.4	12.9			11.4	12.3				11.2	11.2	
42.0	16.5	17.1	17.5	16.3	16.7	17.5	16.3		10.7	11.8	12.9			10.8	12.1	12.3			11.0	11.2	
44.0	16.1	16.6	16.4	15.3	16.2	16.7	15.3	13.7	10.2	11.2	12.5			10.3	11.5	12.3			10.4	11.2	
46.0		16.1	15.4	14.3		15.6	14.3	12.9	9.8	10.7	11.9			9.9	11.0	11.7			10.0	11.2	
48.0			15.4	14.5	13.5		14.7	13.4	12.1		10.2	11.3	10.5		10.4	10.9			9.6	10.7	
50.0				13.7	12.7		14.1	12.6	11.3		9.8	10.8	9.8		10.0	10.2			10.2	8.7	
54.0					11.3			11.2	10.1			9.9	8.5		9.3	8.9	6.5			9.4	7.6
58.0									8.9				7.4			7.8	5.6			6.5	4.0
62.0																	4.8				3.3
66.0																					2.7
θ(°)	5~58	5~56	5~43	5~40	5~56	5~58	5~50	5~45	5~59	5~52	5~41	5~31	5~56	5~62	5~46	5~34	5~58	5~53	5~37	5~35	
標準フック	80t				25t				25t				870kg								
フック質量	1270kg				870kg				870kg												
標準巻掛本数	3				2				2												

注)カウンタウエイト 98t、アウトリガ張出幅 8.5m または、カウンタウエイト 98t、アウトリガ張出幅 8.0m

単位:t

ブーム長さ ブーム起伏角 作業半径(m)	40.4m			45.4m			50.5m					
	83°	75°	65°	83°	75°	65°	83°	75°	65°			
22.0	9.0											
24.0	9.0			6.2								
26.0	9.0			6.2			3.6					
28.0	9.0			6.2			3.6					
30.0	9.0			6.2			3.6					
32.0	9.0			6.2			3.6					
34.0	9.0	9.0		6.2			3.6					
36.0	9.0	9.0		6.2	6.2		3.6					
38.0	9.0	9.0		6.2	6.2		3.6	3.6				
40.0	9.0	9.0		6.2	6.2		3.6	3.6				
42.0	9.0	9.0		6.2	6.2		3.6	3.6				
44.0	9.0	9.0		6.2	6.2		3.6	3.6				
46.0	9.0	9.0		6.2	6.2		3.6	3.6				
48.0	9.0	9.0		8.1	6.2		3.6	3.6				
50.0	9.0	9.0	7.5	6.2	6.2		3.6	3.6				
54.0		9.0	6.4		6.2	5.2		3.6	3.6			
58.0			5.5		6.2	4.4		3.6	3.4			
62.0			4.6			3.7			2.7			
66.0						3.0			2.1			
θ(°)	5~60	5~47	5~41	5~57	5~54	5~46	5~53	5~47	5~37			
標準フック	80t			25t			25t			870kg		
フック質量	1270kg			870kg			870kg					
標準巻掛本数	3			2			2					

注)カウンタウエイト 98t、アウトリガ張出幅 8.5m または、カウンタウエイト 98t、アウトリガ張出幅 8.0m

● LE性能

2.1m+20mラフィングジブ

単位:t

ブーム長さ ブーム起傾角 作業半径(m)	15.0m				20.1m				25.1m				30.2m			35.3m		
	83°	75°	65°	55°	83°	75°	65°	55°	83°	75°	65°	55°	83°	75°	65°	83°	75°	65°
8.0	64.0																	
9.0	64.0				53.0													
10.0	64.0				53.0													
11.0	64.0				53.0			38.8										
12.0	64.0				53.0			38.8				38.8						
14.0	64.0	64.0			53.0			38.8				38.8				34.6		
16.0	59.7	57.8			53.0	53.0		38.8				38.8				34.6		
18.0	51.4	49.6			50.6	47.9		38.4	38.8			38.8				34.6		
20.0	44.8	43.2	41.3		44.1	41.8		37.3	38.8			37.5	38.3		34.6			
22.0		38.2	36.5			36.9	34.3		35.8			37.0	33.8		34.6	32.2		
24.0			32.5	30.5		33.3	30.5		31.8	28.2		30.0				28.6		
26.0			29.1	27.4			27.4		28.5	25.3		26.9				25.7		
28.0				24.8			24.7							20.6				
30.0										20.8				18.7				17.2
32.0														17.1				15.7
34.0																		14.3
θ(°)	5~62	5~52	5~58	5~40	5~56	5~56	5~51	5~50	5~60	5~46	5~57	5~46	5~42	5~50	5~47	5~38		
標準フック	80t				80t				80t				80t					
フック質量	1270kg				1270kg				1270kg				1270kg					
標準巻掛本数	6				5				4				4					

注)カウンタウエイト 78t、アウトリガ張出幅 8.5m
または、カウンタウエイト 78t、アウトリガ張出幅 8.0m

単位:t

ブーム長さ ブーム起傾角 作業半径(m)	40.4m		45.4m		50.5m		55.6m
	83°	75°	83°	75°	83°	75°	83°
16.0	29.2						
18.0	29.2		18.8		11.9		
20.0	29.2		18.8		11.9	7.5	
22.0	29.2		18.8		11.9	7.5	
24.0	29.2	27.4	18.8		11.9	7.5	
26.0		24.6		18.8		7.5	
28.0		22.2		18.8		11.9	
30.0		20.2		18.8		11.9	
32.0						11.9	
θ(°)	5~56	5~49	5~48	5~38	5~42	5~38	5~45
標準フック	80t		25t		25t		25t
フック質量	1270kg		870kg		870kg		870kg
標準巻掛本数	3		3		3		3

注)カウンタウエイト 78t、アウトリガ張出幅 8.5m
または、カウンタウエイト 78t、アウトリガ張出幅 8.0m

● LE性能

2.1m+29mラフィングジブ

単位:t

ブーム長さ ブーム起傾角 作業半径(m)	15.0m				20.1m				25.1m				30.2m				35.3m			
	83°	75°	65°	55°	83°	75°	65°	55°	83°	75°	65°	55°	83°	75°	65°	55°	83°	75°	65°	55°
10.0	47.0																			
11.0	47.0				39.5															
12.0	47.0				39.5			27.5												
14.0	47.0				39.5			27.5				27.5								
16.0	47.0	47.0			39.5			27.5				27.5				24.7				
18.0	47.0	47.0			39.5	39.5		27.5				27.5				24.7				
20.0	44.1	42.7			39.5	39.5		27.5	27.5			27.5				24.7				
22.0	39.0	37.7			38.5	36.4		26.4	27.5			26.7	27.5			24.7				
24.0	34.8	33.6	31.9		34.3	32.4		25.4	27.3			25.6	27.5			24.7	24.7			
26.0	31.4	30.2	28.7		30.9	29.1	26.8		24.6	26.2			24.7	26.3			24.7	24.7		
28.0	28.5	27.3	26.0		28.0	26.3	24.2		23.8	25.3			24.0	23.8			24.1	22.6		
30.0	24.9	23.7	22.1		24.0	22.1		22.8	23.2	20.2			23.1	21.7			23.2	20.6		
32.0	22.9	21.7	20.2		22.0	20.2			21.2	18.5						21.6	18.8			
34.0			20.0	18.6			18.6	16.8		19.5	17.0					18.2	15.0			
36.0				17.2			17.2	15.5			15.7					16.8	13.9			
38.0								14.3		14.5	12.4					12.8				
40.0								13.3			11.5					11.8				
42.0											10.7								8.3	
44.0																			7.7	
46.0																			7.0	
48.0																				5.9
θ(°)	5~60	5~65	5~48	5~35	5~56	5~53	5~46	5~42	5~61	5~55	5~43	5~34	5~56	5~57	5~40	5~38	5~61	5~47	5~38	5~30
標準フック	80t				80t				80t				80t							
フック質量	1270kg				1270kg				1270kg				1270kg							
標準巻掛本数	5				4				3				3							

注)カウンタウエイト 78t、アウトリガ張出幅 8.5m
または、カウンタウエイト 78t、アウトリガ張出幅 8.0m

単位:t

ブーム長さ ブーム起傾角 作業半径(m)	40.4m			45.4m			50.5m			55.6m	
	83°	75°	65°	83°	75°	65°	83°	75°	65°	83°	75°
18.0	20.3										
20.0	20.3			13.4			7.7				
22.0	20.3			13.4			7.7			4.7	
24.0	20.3			13.4			7.7			4.7	
26.0	20.3			13.4			7.7			4.7	
28.0	20.3	20.3		13.4			7.7			4.7	
30.0	20.3	19.5		13.4	13.4		7.7			4.7	
32.0	20.3	17.8		13.4	13.4		7.7	7.7		4.7	
34.0		16.3		13.4	13.4		7.7	7.7	4.7	4.7	
36.0		15.1			13.4			7.7		4.7	
38.0		13.9	10.0		13.2			7.7		4.7	
40.0			9.2		12.2			7.7		4.7	
42.0			8.5			7.2				4.7	
44.0			7.8			6.6			5.5		
46.0			7.1			6.1			5.0		
48.0						5.5			4.5		
50.0									4.1		
θ(°)	5~55	5~48	5~45	5~59	5~49	5~41	5~53	5~41	5~38	5~48	5~41
標準フック	25t			25t			25t		25t		
フック質量	870kg			870kg			870kg		870kg		
標準巻掛本数	2			2			2		2		

注)カウンタウエイト 78t、アウトリガ張出幅 8.5m
または、カウンタウエイト 78t、アウトリガ張出幅 8.0m

● LE性能

2.1m+38mラフィングジブ

単位:t

ブーム長さ ブーム起伏角 作業半径(m)	15.0m				20.1m				25.1m				30.2m				35.3m			
	83°	75°	65°	55°	83°	75°	65°	55°	83°	75°	65°	55°	83°	75°	65°	55°	83°	75°	65°	55°
12.0	35.0																			
14.0	35.0																			
16.0	35.0																			
18.0	35.0																			
20.0	35.0	35.0																		
22.0	35.0	35.0																		
24.0	34.5	33.3																		
26.0	31.0	29.9																		
28.0	28.1	27.1	25.6																	
30.0	25.6	24.7	23.3																	
32.0	23.6	22.6	21.3																	
34.0	21.8	20.8	19.6																	
36.0	20.2	19.2	18.1	16.8																
38.0		17.9	16.8	15.5																
40.0		16.6	15.6	14.4																
42.0			14.6	13.5																
44.0			13.6	12.6																
46.0				11.7																
48.0																				
50.0																				
54.0																				
θ(°)	5~59	5~59	5~60	5~44	5~56	5~62	5~56	5~37	5~60	5~53	5~52	5~32	5~56	5~54	5~48	5~35	5~59	5~55	5~37	5~23
標準フック	80t				80t				25t				25t							
フック質量	1270kg				1270kg				870kg				870kg							
標準巻掛本数	4				3				2				2							

注)カウンタウエイト 78t、アウトリガ張出幅 8.5m
または、カウンタウエイト 78t、アウトリガ張出幅 8.0m

ブーム長さ ブーム起伏角 作業半径(m)	40.4m			45.4m			50.5m		
	83°	75°	65°	83°	75°	65°	83°	75°	65°
20.0	13.4								
22.0	13.4			9.0					
24.0	13.4			9.0			5.2		
26.0	13.4			9.0			5.2		
28.0	13.4			9.0			5.2		
30.0	13.4	13.4		9.0			5.2		
32.0	13.4	13.4		9.0	9.0		5.2		
34.0	13.4	13.4		9.0	9.0		5.2		
36.0	13.4	13.4		9.0	9.0		5.2	5.2	
38.0	13.4	13.4		9.0	9.0		5.2	5.2	
40.0	13.4	12.5		9.0	9.0		5.2	5.2	
42.0		11.6	7.6	9.0	9.0		5.2	5.2	
44.0		10.8	7.0		9.0			5.2	
46.0		10.0	6.4		9.0	5.0		5.2	
48.0		9.4	5.9		8.5	4.5		5.2	
50.0			5.4		4.1			5.2	3.0
54.0			4.4		3.3				2.3
θ(°)	5~55	5~56	5~42	5~57	5~48	5~33	5~53	5~48	5~26
標準フック	25t			25t			25t		
フック質量	870kg			870kg			870kg		
標準巻掛本数	2			2			2		

注)カウンタウエイト 78t、アウトリガ張出幅 8.5m
または、カウンタウエイト 78t、アウトリガ張出幅 8.0m

● LE性能

2.1m+47mラフィングジブ

単位:t

ブーム長さ ブーム起伏角 作業半径(m)	15.0m				20.1m				25.1m				30.2m				35.3m			
	83°	75°	65°	55°	83°	75°	65°	55°	83°	75°	65°	55°	83°	75°	65°	55°	83°	75°	65°	
14.0	26.0																			
16.0	26.0																			
18.0	26.0																			
20.0	26.0																			
22.0	26.0	26.0																		
24.0	24.9	26.0																		
26.0	23.5	25.2																		
28.0	22.2	23.7																		
30.0	21.1	22.4																		
32.0	20.1	21.2	20.9																	
34.0	19.2	20.2	19.2																	
36.0	18.4	18.8	17.7																	
38.0	17.7	17.5	16.4																	
40.0	17.0	16.2	15.2																	
42.0	15.9	15.1	14.1	12.9																
44.0	14.9	14.1	13.2	12.1	14.6															
46.0		13.2	12.4	11.3																
48.0		12.4	11.6	10.5																
50.0			10.9	9.9																
54.0				8.7																
58.0																				
62.0																				
θ(°)	5~58	5~56	5~43	5~40	5~56	5~58	5~50	5~45	5~59	5~52	5~41	5~31	5~56	5~62	5~46	5~34	5~58	5~53	5~37	
標準フック	80t				80t				25t				25t							
フック質量	1270kg				1270kg				870kg				870kg							
標準巻掛本数	3				3				2				2							

注)カウンタウエイト 78t、アウトリガ張出幅 8.5m
または、カウンタウエイト 78t、アウトリガ張出幅 8.0m

ブーム長さ ブーム起伏角 作業半径(m)	40.4m			45.4m			50.5m		
	83°	75°	65°	83°	75°	65°	83°	75°	65°
22.0	9.0								
24.0	9.0			6.2					
26.0	9.0			6.2			3.6		
28.0	9.0			6.2			3.6		
30.0	9.0			6.2			3.6		
32.0	9.0			6.2			3.6		
34.0	9.0	9.0		6.2			3.6		
36.0	9.0	9.0		6.2	6.2		3.6		
38.0	9.0	9.0		6.2	6.2		3.6	3.6	
40.0	9.0	9.0		6.2	6.2		3.6	3.6	
42.0	9.0	9.0		6.2	6.2		3.6	3.6	
44.0	9.0	9.0		6.2	6.2		3.6	3.6	
46.0	9.0	9.0		6.2	6.2		3.6	3.6	
48.0	9.0	8.6	4.8	6.2	6.2		3.6	3.6	
50.0	9.0	8.0	4.3	6.2	6.2	3.1	3.6	3.6	
54.0		6.8	3.5		6.1	2.4		3.6	
58.0			2.8		5.1			3.6	
62.0					2.2				
θ(°)	5~60	5~47	5~41	5~57	5~54	5~18	5~53	5~47	
標準フック	25t			25t			25t		
フック質量	870kg			870kg			870kg		
標準巻掛本数	2			2			2		

注)カウンタウエイト 78t、アウトリガ張出幅 8.5m
または、カウンタウエイト 78t、アウトリガ張出幅 8.0m

● LF性能

2.1m+20mラフingジブ

単位:t

ブーム長さ	15.0m				20.1m				25.1m				30.2m				35.3m		
ブーム起伏角 作業半径(m)	83°	75°	65°	55°	83°	75°	65°	55°	83°	75°	65°	55°	83°	75°	65°	55°	83°	75°	65°
8.0	64.0																		
9.0	64.0				53.0														
10.0	64.0				53.0														
11.0	64.0				53.0			38.8											
12.0	64.0				53.0			38.8				38.8							
14.0	59.9	57.9			53.0			38.8				38.8				34.6			
16.0	50.1	48.3			49.3	46.4		38.8				38.8				34.6			
18.0	42.7	40.9			41.9	39.3		38.4	37.8			38.8				34.6			
20.0	36.9	35.4	33.4		36.2	33.9		35.4	32.7			34.2	30.4		33.2				
22.0		31.0	29.4				27.1		28.7			30.0	26.6		29.1	25.0			
24.0			26.0	24.1			26.8	24.1		25.4	21.7		23.6			22.2			
26.0			23.3	21.6			21.5	21.5		22.7	19.4		21.1			19.8			
28.0				19.4			19.4				17.5			15.3		17.8			
30.0											15.8			13.8				12.2	
32.0														12.5				11.0	
34.0																		9.9	
θ(°)	5~62	5~52	5~58	5~40	5~56	5~56	5~51	5~50	5~60	5~46	5~57	5~46	5~42	5~50	5~47	5~38			
標準フック	80t				80t				80t				80t						
フック質量	1270kg				1270kg				1270kg				1270kg						
標準巻掛本数	6				5				4				4						

注)カウンタウエイト 78t、アウトリガ張出幅 6.8m
 または、カウンタウエイト 58t、アウトリガ張出幅 8.5m
 または、カウンタウエイト 58t、アウトリガ張出幅 8.0m

単位:t

ブーム長さ	40.4m		45.4m		50.5m		55.6m
ブーム起伏角 作業半径(m)	83°	75°	83°	75°	83°	75°	83°
16.0	29.2						
18.0	29.2		18.8		11.9		
20.0	29.2		18.8		11.9	7.5	
22.0	28.4		18.8		11.9	7.5	
24.0	25.1	20.9	18.8		11.9	7.5	
26.0		18.7		17.5		7.5	
28.0		16.8		15.7		11.9	
30.0		15.2		14.2		11.9	
32.0						11.9	
θ(°)	5~56	5~49	5~48	5~38	5~42	5~38	5~45
標準フック	80t		25t		25t		
フック質量	1270kg		870kg		870kg		
標準巻掛本数	3		3		3		

注)カウンタウエイト 78t、アウトリガ張出幅 6.8m
 または、カウンタウエイト 58t、アウトリガ張出幅 8.5m
 または、カウンタウエイト 58t、アウトリガ張出幅 8.0m

● LF性能

2.1m+29mラフingジブ

単位:t

ブーム長さ	15.0m				20.1m				25.1m				30.2m				35.3m		
ブーム起伏角 作業半径(m)	83°	75°	65°	55°	83°	75°	65°	55°	83°	75°	65°	55°	83°	75°	65°	55°	83°	75°	65°
10.0	47.0																		
11.0	47.0				39.5														
12.0	47.0				39.5			27.5											
14.0	47.0				39.5			27.5				27.5							
16.0	47.0	47.0			39.5			27.5				27.5						24.7	
18.0	41.9	40.4			39.5	39.4		27.5				27.5						24.7	
20.0	36.2	34.9			35.6	33.4		27.5	27.5			27.5						24.7	
22.0	31.9	30.6			31.3	29.3		26.4	27.5			26.7	25.9					24.7	
24.0	28.4	27.2	25.5		27.9	26.0		25.4	24.9			25.6	22.9			24.7	21.5		
26.0	25.6	24.3	22.8		25.0	23.2	20.9		24.4	22.3		23.4	20.5			22.8	19.2		
28.0	23.1	22.0	20.6		22.6	21.0	18.9		22.0	20.1		21.2	18.5			20.6	17.3		
30.0		20.0	18.7	17.1		19.0	17.1		20.0	18.3	15.2		19.2	16.7		18.7	15.6		
32.0		18.3	17.1	15.6		17.4	15.6			16.7	13.9			15.2	11.8		17.0	14.2	
34.0			15.7	14.3			14.3	12.5		15.2	12.7			13.9	10.8			13.0	
36.0				13.2				13.1	11.5		11.6			12.8	9.8		11.9	8.1	
38.0									10.5		10.7	8.5			8.9			7.4	
40.0									9.7			7.7			8.1	5.1		6.7	
42.0												7.0				4.6		6.0	
44.0																4.1			
46.0																3.6			
θ(°)	5~60	5~65	5~48	5~35	5~56	5~53	5~46	5~42	5~61	5~55	5~43	5~34	5~56	5~57	5~40	5~38	5~61	5~47	5~38
標準フック	80t				80t				80t				80t				25t		
フック質量	1270kg				1270kg				1270kg				1270kg				870kg		
標準巻掛本数	5				4				3				3				3		

注)カウンタウエイト 78t、アウトリガ張出幅 6.8m
 または、カウンタウエイト 58t、アウトリガ張出幅 8.5m
 または、カウンタウエイト 58t、アウトリガ張出幅 8.0m

単位:t

ブーム長さ	40.4m			45.4m			50.5m			55.6m
ブーム起伏角 作業半径(m)	83°	75°	65°	83°	75°	65°	83°	75°	83°	75°
18.0	20.3									
20.0	20.3			13.4			7.7			
22.0	20.3			13.4			7.7		4.7	
24.0	20.3			13.4			7.7		4.7	
26.0	20.3			13.4			7.7		4.7	
28.0	19.8	16.0		13.4			7.7		4.7	
30.0	18.0	14.5		13.4	13.4		7.7		4.7	
32.0	16.4	13.2		13.4	12.3		7.7	7.7	4.7	
34.0		12.1		13.4	11.2		7.7	7.7	4.7	4.7
36.0		11.0			10.3			7.7		4.7
38.0		10.1	5.8		9.4			7.7		4.7
40.0			5.2		8.6			7.7		4.7
42.0			4.7			3.5				4.7
44.0			4.2			3.0				
46.0			3.7			2.6				
48.0						2.2				
θ(°)	5~55	5~48	5~45	5~59	5~49	5~41	5~53	5~41	5~48	5~41
標準フック	25t			25t			25t			
フック質量	870kg			870kg			870kg			
標準巻掛本数	2			2			2			

注)カウンタウエイト 78t、アウトリガ張出幅 6.8m
 または、カウンタウエイト 58t、アウトリガ張出幅 8.5m
 または、カウンタウエイト 58t、アウトリガ張出幅 8.0m

● LF性能

2.1m+38mラフィングジブ

単位:t

ブーム長さ	15.0m				20.1m				25.1m				30.2m			35.3m		
ブーム起伏角 作業半径(m)	83°	75°	65°	55°	83°	75°	65°	55°	83°	75°	65°	55°	83°	75°	65°	83°	75°	65°
12.0	35.0																	
14.0	35.0				29.5				18.7									
16.0	35.0				29.5				18.7					18.5				
18.0	35.0				29.5				18.7					18.5			16.9	
20.0	35.0	34.6			29.5				18.7					18.5			16.9	
22.0	31.6	30.3			29.5	29.4			18.7					18.5			16.9	
24.0	28.0	26.9			27.4	25.6			18.7	18.7				18.5			16.9	
26.0	25.1	24.1			24.6	22.9			18.7	18.7				18.5	18.5		16.9	
28.0	22.7	21.7	20.2		22.2	20.6			18.7	18.7				18.5	17.9		16.9	16.5
30.0	20.7	19.7	18.3		20.2	18.7	16.6		18.1	17.9				18.2	16.2		16.9	14.9
32.0	19.0	18.0	16.7		18.5	17.0	15.1		17.1	16.3				17.2	14.8		16.5	13.5
34.0	17.5	16.5	15.3		17.0	15.6	13.8		16.3	14.9	12.2			15.8	13.5		15.1	12.4
36.0	16.1	15.2	14.1	12.7	15.7	14.4	12.7		15.3	13.7	11.1			14.5	12.4	9.0	13.9	11.3
38.0		14.1	13.0	11.8		13.3	11.7		14.1	12.6	10.2			13.4	11.4	8.2	12.8	10.4
40.0		13.1	12.1	10.9		12.3	10.8	9.2		11.7	9.4				10.5	7.4	11.9	9.6
42.0			11.2	10.1		11.6	10.0	8.5		10.8	8.7	6.3			9.7	6.8	8.8	5.1
44.0			10.4	9.3			9.3	7.8			8.1	5.7			9.0	6.2	8.2	4.6
46.0				8.7			8.6	7.2			7.4	5.2				5.6	7.5	4.1
48.0								6.6			6.8	4.7					5.1	3.7
50.0											4.3					4.6		3.3
θ(°)	5~59	5~59	5~60	5~44	5~56	5~62	5~56	5~37	5~60	5~53	5~52	5~32	5~56	5~54	5~48	5~59	5~55	5~37
標準フック	80t				80t				25t				25t			25t		
フック質量	1270kg				1270kg				870kg				870kg			870kg		
標準巻掛本数	4				3				2				2			2		

注)カウンタウイト 78t、アウトリガ張出幅 6.8m
 または、カウンタウイト 58t、アウトリガ張出幅 8.5m
 または、カウンタウイト 58t、アウトリガ張出幅 8.0m

単位:t

ブーム長さ	40.4m			45.4m		50.5m	
ブーム起伏角 作業半径(m)	83°	75°	65°	83°	75°	83°	75°
20.0	13.4						
22.0	13.4			9.0			
24.0	13.4			9.0	5.2		
26.0	13.4			9.0	5.2		
28.0	13.4			9.0	5.2		
30.0	13.4	13.4		9.0	5.2		
32.0	13.4	12.6		9.0	9.0	5.2	
34.0	13.4	11.5		9.0	9.0	5.2	
36.0	13.4	10.5		9.0	9.0	5.2	5.2
38.0	12.5	9.7		9.0	8.5	5.2	5.2
40.0	11.5	8.9		9.0	7.7	5.2	5.2
42.0		8.1	3.9	9.0	7.0	5.2	5.2
44.0		7.4	3.4		6.4		5.2
46.0		6.8	3.0		5.8		5.0
48.0		6.2	2.6		5.3		4.5
50.0			2.2		4.0		4.0
θ(°)	5~55	5~56	5~29	5~57	5~48	5~53	5~48
標準フック	25t			25t		25t	
フック質量	870kg			870kg		870kg	
標準巻掛本数	2			2		2	

注)カウンタウイト 78t、アウトリガ張出幅 6.8m
 または、カウンタウイト 58t、アウトリガ張出幅 8.5m
 または、カウンタウイト 58t、アウトリガ張出幅 8.0m

● LG性能

2.1m+20mラフィングジブ

単位:t

ブーム長さ	15.0m				20.1m			25.1m			30.2m			35.3m		
ブーム起伏角 作業半径(m)	83°	75°	65°	55°	83°	75°	65°	83°	75°	65°	83°	75°	65°	83°	75°	65°
8.0	64.0															
9.0	64.0				53.0											
10.0	64.0				53.0											
11.0	64.0				53.0			38.8								
12.0	63.6				53.0			38.8			38.8					
14.0	51.1	49.0			50.1			38.8			38.8			34.6		
16.0	42.6	40.7			41.8	38.9		38.8			38.8			34.6		
18.0	36.5	34.7			35.7	33.1		34.7	31.7		33.4			32.4		
20.0	31.6	30.1	28.2		31.0	28.7		30.1	27.5		29.0	25.2		28.1		
22.0		26.5	24.8			25.2	22.7		24.1		25.5	22.2		24.6	20.6	
24.0			22.0	20.1		22.8	20.1		21.4	17.8		19.7			18.3	
26.0			19.7	18.0			18.0		19.1	16.0		17.6			16.3	
28.0			16.2				16.2			14.4			12.2		14.7	
30.0									12.9				11.0			9.0
32.0													9.9			8.1
34.0																7.2
θ(°)	5~62	5~52	5~58	5~40	5~56	5~56	5~51	5~50	5~60	5~46	5~57	5~46	5~42	5~50	5~47	5~38
標準フック	80t				80t			80t			80t			80t		
フック質量	1270kg				1270kg			1270kg			1270kg			1270kg		
標準巻掛本数	6				5			4			4			4		

注)カウンタウイト 58t、アウトリガ張出幅 6.8m
 または、カウンタウイト 47t、アウトリガ張出幅 8.5m
 または、カウンタウイト 47t、アウトリガ張出幅 8.0m

単位:t

ブーム長さ	40.4m		45.4m		50.5m		55.6m
ブーム起伏角 作業半径(m)	83°	75°	83°	75°	83°	75°	83°
16.0	29.2						
18.0	29.2		18.8			11.9	
20.0	27.3		18.8			11.9	7.5
22.0	23.9		18.8			11.9	7.5
24.0	21.2	17.1	18.8			11.9	7.5
26.0		15.2		14.1			7.5
28.0		13.7		12.6			11.7
30.0		12.3		11.4			10.4
32.0							9.4
θ(°)	5~56	5~49	5~48	5~38	5~42	5~38	5~45
標準フック	80t		25t		25t		25t
フック質量	1270kg		870kg		870kg		870kg
標準巻掛本数	3		3		3		3

注)カウンタウイト 58t、アウトリガ張出幅 6.8m
 または、カウンタウイト 47t、アウトリガ張出幅 8.5m
 または、カウンタウイト 47t、アウトリガ張出幅 8.0m

● LG性能

2.1m+29mラフィングジブ

単位:t

ブーム長さ ブーム起傾角 作業半径(m)	15.0m				20.1m				25.1m				30.2m			35.3m		
	83°	75°	65°	55°	83°	75°	65°	55°	83°	75°	65°	55°	83°	75°	65°	83°	75°	65°
10.0	47.0																	
11.0	47.0				39.5													
12.0	47.0				39.5				27.5									
14.0	47.0				39.5				27.5					27.5				
16.0	41.9	40.1			39.5				27.5					27.5			24.7	
18.0	35.7	34.1			35.0	33.1			27.5					27.5			24.7	
20.0	31.0	29.6			30.4	28.2			27.5	26.8				27.5			24.7	
22.0	27.3	26.0			26.8	24.7			26.1	23.5				25.0	21.4		24.2	
24.0	24.3	23.1	21.4		23.9	21.9			23.2	20.9				22.2	19.0		21.5	17.5
26.0	22.0	20.7	19.2		21.4	19.7	17.4		20.8	18.7				19.9	16.9		19.2	15.7
28.0	19.9	18.7	17.3		19.4	17.7	15.6		18.8	16.9				17.9	15.3		17.3	14.1
30.0		17.0	15.7	14.2		16.1	14.2		17.1	15.3	12.4			16.3	13.8		15.7	12.7
32.0			15.6	14.4	12.9		14.7	12.9		13.9	11.2				12.6	8.9	14.3	11.6
34.0				13.1	11.8			11.8	10.0		12.7	10.2			11.5	8.0		10.5
36.0					10.8			10.8	9.2			9.3			10.5	7.2		9.6
38.0									8.4			8.6	6.1			6.5		5.0
40.0										7.6					5.5	5.9		4.4
42.0															4.9			3.9
θ(°)	5~60	5~65	5~48	5~35	5~56	5~53	5~46	5~42	5~61	5~55	5~43	5~34	5~56	5~57	5~40	5~61	5~47	5~38
標準フック	80t				80t				80t				80t			25t		
フック質量	1270kg				1270kg				1270kg				870kg			870kg		
標準巻掛本数	5				4				3				3			3		

注)カウンタウエイト 58t、アウトリガ張出幅 6.8m
 または、カウンタウエイト 47t、アウトリガ張出幅 8.5m
 または、カウンタウエイト 47t、アウトリガ張出幅 8.0m

単位:t

ブーム長さ ブーム起傾角 作業半径(m)	40.4m			45.4m		50.5m		55.6m	
	83°	75°	65°	83°	75°	83°	75°	83°	75°
18.0	20.3								
20.0	20.3			13.4		7.7			
22.0	20.3			13.4		7.7		4.7	
24.0	20.3			13.4		7.7		4.7	
26.0	18.5			13.4		7.7		4.7	
28.0	16.6	12.9		13.4		7.7		4.7	
30.0	15.1	11.6		13.4	10.6	7.7		4.7	
32.0	13.7	10.5		13.4	9.5	7.7	7.7	4.7	
34.0		9.6		12.3	8.6	7.7	7.5	4.7	4.7
36.0		8.7			7.8		6.8		4.7
38.0		7.9	3.5		7.0		6.1		4.7
40.0			3.0		6.3		5.5		4.5
42.0			2.6						4.0
θ(°)	5~55	5~48	5~27	5~59	5~49	5~53	5~41	5~48	5~41
標準フック	25t								
フック質量	870kg								
標準巻掛本数	2								

注)カウンタウエイト 58t、アウトリガ張出幅 6.8m
 または、カウンタウエイト 47t、アウトリガ張出幅 8.5m
 または、カウンタウエイト 47t、アウトリガ張出幅 8.0m

5. ラフィングジブ+エクステンションジブ定格総荷重表

1. 定格総荷重表の性能区分LA～LEは、下表のとおりです。

カウンタウエイト アウトリガ 張出幅	138 t	118 t	98 t	78 t
8.5m	LA	LB	LD	LE
8.0m		LC	LD	LE

2. 定格総荷重は、つり具質量とフック質量（25 トフック：870 kg、11.3 トフック：440 kg）を含んだ値を示します。
3. 定格総荷重は、ブームのたわみを含んだ実際の作業半径に基づいています。
4. 各ブーム長さにおける各ブーム段の伸長状態（伸長割合%）は、下表のとおりです。

ブーム長さ	15.0m	20.1m	25.1m	30.2m	35.3m	40.4m	45.4m	50.5m
伸縮ブーム1	0	0	45	90	90	90	90	90
伸縮ブーム2	0	45	45	45	90	90	90	90
伸縮ブーム3	0	0	0	0	0	45	90	90
伸縮ブーム4	0	0	0	0	0	0	0	45

5. 定格総荷重表中の標準巻掛本数よりも少ない本数で使用する場合
・巻掛本数の下限、および最大荷重の上限は下表のとおりです。

ジブ長さ	47m+9m
最小巻掛本数	1本
最大荷重	11.3t

6. Bピン（ブーム固定ピン）を挿入していない状態では使用できません。
7. 定格総荷重は、アウトリガを水平堅土上に設置したときの値です。
8. 定格総荷重表は、風による影響を含んでいません。瞬間最大風速が10m/s以上の風速では、クレーン作業を中止してください。
9. 定格総荷重表中の太線より上側はクレーンの強度に、下側はクレーンの安定に基づいています。
10. 「 θ (°)」は、無負荷状態で作動可能なジブオフセット角度範囲を示します。
オフセットは下図のように、ブームの中心線とジブの中心線とのなす角度を示します。

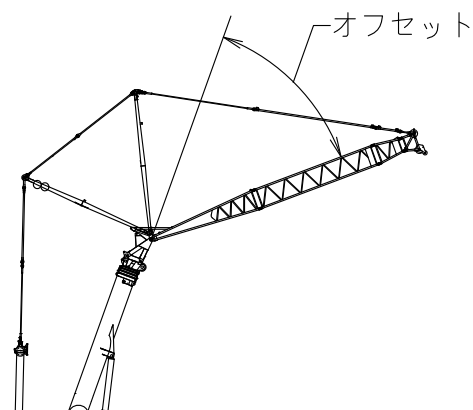

●LA性能

2. 1m+4.7mラフィンギジブ+9mエクステンションジブ

単位:t

ブーム長さ ブーム起伏角 作業半径(m)	15.0m				20.1m				25.1m				30.2m			
	83°	75°	65°	55°	83°	75°	65°	55°	83°	75°	65°	55°	83°	75°	65°	55°
18.0	16.8															
20.0	16.8				14.9				9.0							
22.0	16.8				14.9				9.0				7.9			
24.0	16.4				14.9				9.0				7.9			
26.0	15.8				14.9				9.0				7.9			
28.0	15.2	15.9			14.9				9.0				7.9			
30.0	14.6	15.3			14.8	14.9			9.0				7.9			
32.0	13.9	14.7			14.1	14.9			9.0	9.0			7.9			
34.0	13.2	14.0			13.4	14.5			9.0	9.0			7.9	7.9		
36.0	12.6	13.3			12.8	13.7			9.0	9.0			7.9	7.9		
38.0	12.0	12.7			12.2	13.1			9.0	9.0			7.9	7.9		
40.0	11.5	12.1	12.9		11.7	12.5			9.0	9.0			7.9	7.9		
42.0	11.0	11.6	12.3		11.2	11.9	12.9		9.0	9.0			7.9	7.9		
44.0	10.6	11.1	11.8		10.7	11.4	12.3		9.0	9.0	9.0		7.9	7.9		
46.0	10.2	10.7	11.3		10.3	11.0	11.8		9.0	9.0	9.0		7.9	7.9		
48.0	9.9	10.3	10.8	11.4	10.0	10.5	11.3		9.0	9.0	9.0		7.9	7.9	7.9	
50.0	9.6	9.9	10.4	10.9	9.7	10.2	10.9		9.0	9.0	9.0		7.9	7.9	7.9	
54.0			9.7	10.1		9.5	10.1	10.7		9.0	9.0			7.9	7.9	
58.0				9.5			9.5	10.0			9.0		9.0			7.9
62.0												9.0				7.9
66.0																7.9
θ(°)	5~52	5~39	5~32	5~25	5~50	5~45	5~36	5~19	5~49	5~41	5~31	5~21	5~47	5~38	5~34	5~22
標準フック	25t								11.3t							
フック質量	870kg								440kg							
標準巻掛本数	2								1							

注)カウンタウエイト 138t、アウトリガ張出幅 8.5m

●LA性能

2. 1m+4.7mラフィンギジブ+9mエクステンションジブ

単位:t

ブーム長さ ブーム起伏角 作業半径(m)	35.3m				40.4m			45.4m			50.5m		
	83°	75°	65°	55°	83°	75°	65°	83°	75°	65°	83°	75°	65°
24.0	6.9												
26.0	6.9				5.1								
28.0	6.9				5.1			4.0					
30.0	6.9				5.1			4.0			2.7		
32.0	6.9				5.1			4.0			2.7		
34.0	6.9				5.1			4.0			2.7		
36.0	6.9	6.9			5.1			4.0			2.7		
38.0	6.9	6.9			5.1			4.0			2.7		
40.0	6.9	6.9			5.1	5.1		4.0			2.7		
42.0	6.9	6.9			5.1	5.1		4.0	4.0		2.7		
44.0	6.9	6.9			5.1	5.1		4.0	4.0		2.7	2.7	
46.0	6.9	6.9			5.1	5.1		4.0	4.0		2.7	2.7	
48.0	6.9	6.9			5.1	5.1		4.0	4.0		2.7	2.7	
50.0	6.9	6.9	6.9		5.1	5.1		4.0	4.0		2.7	2.7	
54.0		6.9	6.9		5.1	5.1	5.1	4.0	4.0		2.7	2.7	
58.0		6.9	6.9			5.1		4.0	4.0	4.0		2.7	
62.0			6.9				5.1			4.0		2.7	2.7
66.0				6.0			5.1			4.0			2.7
70.0				5.4									2.4
θ(°)	5~44	5~42	5~28	5~24	5~49	5~37	5~30	5~46	5~34	5~25	5~44	5~38	5~27
標準フック	11.3t												
フック質量	440kg												
標準巻掛本数	1												

注)カウンタウエイト 138t、アウトリガ張出幅 8.5m

●LA性能

2. 1m+4.7mラフィンギジブ+17mエクステンションジブ

単位:t

ブーム長さ ブーム起伏角 作業半径(m)	15.0m				20.1m				25.1m				30.2m			
	83°	75°	65°	55°	83°	75°	65°	55°	83°	75°	65°	55°	83°	75°	65°	55°
22.0	9.8															
24.0	9.8				9.6				5.8							
26.0	9.8				9.6				5.8				5.3			
28.0	9.8				9.6				5.8				5.3			
30.0	9.3				9.6				5.8				5.3			
32.0	8.9	9.4			9.4				5.8				5.3			
34.0	8.5	9.0			9.0	9.6			5.8				5.3			
36.0	8.2	8.6			8.6	9.2			5.8	5.8			5.3			
38.0	7.9	8.2			8.3	8.8			5.8	5.8			5.3	5.3		
40.0	7.6	7.9			7.9	8.4			5.8	5.8			5.3	5.3		
42.0	7.3	7.6			7.7	8.1			5.8	5.8			5.3	5.3		
44.0	7.0	7.3	7.7		7.4	7.8			5.8	5.8			5.3	5.3		
46.0	6.8	7.1	7.4		7.1	7.5			5.8	5.8			5.3	5.3		
48.0	6.6	6.9	7.2		6.9	7.3	7.7		5.8	5.8			5.3	5.3		
50.0	6.4	6.6	6.9		6.7	7.0	7.5		5.8	5.8	5.8		5.3	5.3		
54.0	6.1	6.3	6.5		6.4	6.6	7.0		5.8	5.8	5.8		5.3	5.3	5.3	
58.0	5.8	6.0	6.2	6.4	6.1	6.3	6.6	6.9	5.8	5.8	5.8		5.3	5.3	5.3	
62.0		5.8	5.9	6.1	5.9	6.0	6.2	6.5	5.8	5.8	5.8	5.8	5.3	5.3	5.3	
66.0			5.7	5.8			6.0	6.2		5.8	5.8	5.8		5.3	5.3	5.3
70.0								6.0			5.8	5.8			5.3	5.3
74.0											5.8	5.8				5.3
θ(°)	5~53	5~48	5~42	5~26	5~60	5~45	5~36	5~27	5~58	5~51	5~40	5~30	5~56	5~47	5~34	5~23
標準フック	11.3t															
フック質量	440kg															
標準巻掛本数	1															

注)カウンタウエイト 138t、アウトリガ張出幅 8.5m

●LA性能

2. 1m+47mラフィンジブ+17mエクステンションジブ

単位:t

ブーム長さ	35.3m				40.4m				45.4m				50.5m		
ブーム起伏角 作業半径(m)	83°	75°	65°	55°	83°	75°	65°	55°	83°	75°	65°	55°	83°	75°	65°
28.0	4.6				3.4										
30.0	4.6				3.4				2.6						
32.0	4.6				3.4				2.6				1.9		
34.0	4.6				3.4				2.6				1.9		
36.0	4.6				3.4				2.6				1.9		
38.0	4.6				3.4				2.6				1.9		
40.0	4.6	4.6			3.4				2.6				1.9		
42.0	4.6	4.6			3.4	3.4			2.6				1.9		
44.0	4.6	4.6			3.4	3.4			2.6				1.9		
46.0	4.6	4.6			3.4	3.4			2.6	2.6			1.9		
48.0	4.6	4.6			3.4	3.4			2.6	2.6			1.9	1.9	
50.0	4.6	4.6			3.4	3.4			2.6	2.6			1.9	1.9	
54.0	4.6	4.6			3.4	3.4			2.6	2.6			1.9	1.9	
58.0	4.6	4.6	4.6		3.4	3.4	3.4		2.6	2.6			1.9	1.9	
62.0	4.6	4.6	4.6		3.4	3.4	3.4		2.6	2.6	2.6		1.9	1.9	
66.0		4.6	4.6			3.4	3.4			2.6	2.6	2.6		1.9	1.9
70.0			4.6	4.6		3.4	3.4			2.6	2.6			1.9	1.9
74.0			4.6	4.6			3.4	3.4			2.6				1.9
78.0				4.5				3.4	3.4			2.6	2.2		1.7
82.0									2.8				1.8		
θ(°)	5~54	5~43	5~38	5~25	5~51	5~48	5~32	5~26	5~48	5~43	5~34	5~19	5~46	5~39	5~29
標準フック	11.3t														
フック質量	440kg														
標準巻掛本数	1														

注)カウンタウエイト 138t、アウトリガ張出幅 8.5m

●LA性能

2. 1m+47mラフィンジブ+25mエクステンションジブ

単位:t

ブーム長さ	15.0m				20.1m				25.1m				30.2m			
ブーム起伏角 作業半径(m)	83°	75°	65°	55°	83°	75°	65°	55°	83°	75°	65°	55°	83°	75°	65°	55°
24.0	6.3				5.8											
26.0	6.3				5.8				3.6				3.3			
28.0	6.3				5.8				3.6				3.3			
30.0	6.3				5.8				3.6				3.3			
32.0	6.3				5.8				3.6				3.3			
34.0	6.3	6.3			5.8				3.6				3.3			
36.0	6.3	6.3			5.8	5.8			3.6				3.3			
38.0	6.3	6.3			5.8	5.8			3.6	3.6			3.3	3.3		
40.0	6.0	6.3			5.8	5.8			3.6	3.6			3.3	3.3		
42.0	5.7	6.1			5.8	5.8			3.6	3.6			3.3	3.3		
44.0	5.5	5.8			5.6	5.8			3.6	3.6			3.3	3.3		
46.0	5.2	5.5			5.3	5.7			3.6	3.6			3.3	3.3		
48.0	5.0	5.3	5.6		5.1	5.4			3.6	3.6			3.3	3.3		
50.0	4.8	5.0	5.3		4.9	5.2			3.6	3.6			3.3	3.3		
54.0	4.4	4.7	4.9		4.5	4.8	5.1		3.6	3.6	3.6		3.3	3.3		
58.0	4.1	4.3	4.5		4.2	4.4	4.7		3.6	3.6	3.6		3.3	3.3	3.3	
62.0	3.9	4.0	4.2	4.4	3.9	4.1	4.4		3.6	3.6	3.6		3.3	3.3	3.3	
66.0	3.6	3.8	3.9	4.1	3.7	3.9	4.1	4.3	3.6	3.6	3.6		3.3	3.3	3.3	
70.0		3.6	3.7	3.8	3.5	3.6	3.8	4.0	3.5	3.6	3.6	3.6	3.3	3.3	3.3	3.3
74.0		3.4	3.5	3.6		3.4	3.6	3.8		3.5	3.6	3.6	3.3	3.3	3.3	3.3
78.0				3.4			3.4	3.6			3.5	3.6		3.3	3.3	3.3
82.0								3.4				3.5			3.3	3.3
86.0																3.3
θ(°)	5~54	5~61	5~42	5~37	5~61	5~56	5~47	5~40	5~59	5~52	5~41	5~31	5~58	5~60	5~46	5~34
標準フック	11.3t															
フック質量	440kg															
標準巻掛本数	1															

注)カウンタウエイト 138t、アウトリガ張出幅 8.5m

●LA性能

2. 1m+47mラフィンジブ+25mエクステンションジブ

単位:t

ブーム長さ	35.3m				40.4m				45.4m				50.5m		
ブーム起伏角 作業半径(m)	83°	75°	65°	55°	83°	75°	65°	55°	83°	75°	65°	55°	83°	75°	65°
28.0	3.0														
30.0	3.0				2.1										
32.0	3.0				2.1				1.6						
34.0	3.0				2.1				1.6				1.3		
36.0	3.0				2.1				1.6				1.3		
38.0	3.0				2.1				1.6				1.3		
40.0	3.0				2.1				1.6				1.3		
42.0	3.0	3.0			2.1				1.6				1.3		
44.0	3.0	3.0			2.1	2.1			1.6				1.3		
46.0	3.0	3.0			2.1	2.1			1.6				1.3		
48.0	3.0	3.0			2.1	2.1			1.6	1.6			1.3		
50.0	3.0	3.0			2.1	2.1			1.6	1.6			1.3	1.3	
54.0	3.0	3.0			2.1	2.1			1.6	1.6			1.3	1.3	
58.0	3.0	3.0			2.1	2.1			1.6	1.6			1.3	1.3	
62.0	3.0	3.0	3.0		2.1	2.1	2.1		1.6	1.6			1.3	1.3	
66.0	3.0	3.0	3.0		2.1	2.1	2.1		1.6	1.6	1.6		1.3	1.3	
70.0	3.0	3.0	3.0		2.1	2.1	2.1		1.6	1.6	1.6		1.3	1.3	1.3
74.0		3.0	3.0	3.0		2.1	2.1	2.1	1.6	1.6	1.6		1.3	1.3	1.3
78.0		3.0	3.0	3.0		2.1	2.1	2.1		1.6	1.6			1.3	1.3
82.0			3.0	3.0			2.1	2.1			1.6	1.6			1.3
86.0				3.0				2.1	2.1			1.6	1.5		
90.0								2.1							
θ(°)	5~56	5~54	5~40	5~36	5~53	5~50	5~42	5~28	5~58	5~45	5~36	5~15	5~55	5~49	5~20
標準フック	11.3t														
フック質量	440kg														
標準巻掛本数	1														

注)カウンタウエイト 138t、アウトリガ張出幅 8.5m

●LB性能

2. 1m+47mラフィングジブ+9mエクステンションジブ

単位:t

ブーム長さ	15.0m				20.1m				25.1m				30.2m			
ブーム起伏角 作業半径(m)	83°	75°	65°	55°	83°	75°	65°	55°	83°	75°	65°	55°	83°	75°	65°	55°
18.0	16.8															
20.0	16.8				14.9				9.0							
22.0	16.8				14.9				9.0				7.9			
24.0	16.4				14.9				9.0				7.9			
26.0	15.8				14.9				9.0				7.9			
28.0	15.2	15.9			14.9				9.0				7.9			
30.0	14.6	15.3			14.8	14.9			9.0				7.9			
32.0	13.9	14.7			14.1	14.9			9.0	9.0			7.9			
34.0	13.2	14.0			13.4	14.5			9.0	9.0			7.9	7.9		
36.0	12.6	13.3			12.8	13.7			9.0	9.0			7.9	7.9		
38.0	12.0	12.7			12.2	13.1			9.0	9.0			7.9	7.9		
40.0	11.5	12.1	12.9		11.7	12.5			9.0	9.0			7.9	7.9		
42.0	11.0	11.6	12.3		11.2	11.9	12.9		9.0	9.0			7.9	7.9		
44.0	10.6	11.1	11.8		10.7	11.4	12.3		9.0	9.0	9.0		7.9	7.9		
46.0	10.2	10.7	11.3		10.3	11.0	11.8		9.0	9.0	9.0		7.9	7.9		
48.0	9.9	10.3	10.8	11.4	10.0	10.5	11.3		9.0	9.0	9.0		7.9	7.9	7.9	
50.0	9.6	9.9	10.4	10.9	9.7	10.2	10.9		9.0	9.0	9.0		7.9	7.9	7.9	
54.0			9.7	10.1		9.5	10.1	10.7		9.0	9.0			7.9	7.9	
58.0				9.5			9.5	10.0			9.0	9.0				7.9
62.0												8.6			7.9	7.1
66.0																6.2
θ(°)	5~52	5~39	5~32	5~25	5~50	5~45	5~36	5~19	5~49	5~41	5~31	5~21	5~47	5~38	5~34	5~22
標準フック	25t								11.3t							
フック質量	870kg								440kg							
標準巻掛本数	2								1							

注)カウンタウエイト 118t、アウトリガ張出幅 8.5m

●LB性能

2. 1m+47mラフィングジブ+9mエクステンションジブ

単位:t

ブーム長さ	35.3m				40.4m			45.4m			50.5m		
ブーム起伏角 作業半径(m)	83°	75°	65°	55°	83°	75°	65°	83°	75°	65°	83°	75°	65°
24.0	6.9												
26.0	6.9				5.1								
28.0	6.9				5.1			4.0					
30.0	6.9				5.1			4.0			2.7		
32.0	6.9				5.1	1.9		4.0			2.7		
34.0	6.9				5.1			4.0			2.7		
36.0	6.9	6.9			5.1			4.0			2.7		
38.0	6.9	6.9			5.1			4.0			2.7		
40.0	6.9	6.9			5.1	5.1		4.0			2.7		
42.0	6.9	6.9			5.1	5.1		4.0	4.0		2.7		
44.0	6.9	6.9			5.1	5.1		4.0	4.0		2.7	2.7	
46.0	6.9	6.9			5.1	5.1		4.0	4.0		2.7	2.7	
48.0	6.9	6.9			5.1	5.1		4.0	4.0		2.7	2.7	
50.0	6.9	6.9	6.9		5.1	5.1		4.0	4.0		2.7	2.7	
54.0		6.9	6.9		5.1	5.1	5.1	4.0	4.0		2.7	2.7	
58.0		6.9	6.9			5.1		4.0	4.0	4.0		2.7	
62.0			6.9				5.1			4.0		2.7	2.7
66.0				4.8			5.1			4.0			2.7
70.0				4.1									2.4
θ(°)	5~44	5~42	5~28	5~24	5~49	5~37	5~30	5~46	5~34	5~25	5~44	5~38	5~27
標準フック	11.3t												
フック質量	440kg												
標準巻掛本数	1												

注)カウンタウエイト 118t、アウトリガ張出幅 8.5m

●LB性能

2. 1m+47mラフィングジブ+17mエクステンションジブ

単位:t

ブーム長さ	15.0m				20.1m				25.1m				30.2m			
ブーム起伏角 作業半径(m)	83°	75°	65°	55°	83°	75°	65°	55°	83°	75°	65°	55°	83°	75°	65°	55°
22.0	9.8															
24.0	9.8				9.6				5.8							
26.0	9.8				9.6				5.8				5.3			
28.0	9.8				9.6				5.8				5.3			
30.0	9.3				9.6				5.8				5.3			
32.0	8.9	9.4			9.4				5.8				5.3			
34.0	8.5	9.0			9.0	9.6			5.8				5.3			
36.0	8.2	8.6			8.6	9.2			5.8	5.8			5.3			
38.0	7.9	8.2			8.3	8.8			5.8	5.8			5.3	5.3		
40.0	7.6	7.9			7.9	8.4			5.8	5.8			5.3	5.3		
42.0	7.3	7.6			7.7	8.1			5.8	5.8			5.3	5.3		
44.0	7.0	7.3	7.7		7.4	7.8			5.8	5.8			5.3	5.3		
46.0	6.8	7.1	7.4		7.1	7.5			5.8	5.8			5.3	5.3		
48.0	6.6	6.9	7.2		6.9	7.3	7.7		5.8	5.8			5.3	5.3		
50.0	6.4	6.6	6.9		6.7	7.0	7.5		5.8	5.8	5.8		5.3	5.3		
54.0	6.1	6.3	6.5		6.4	6.6	7.0		5.8	5.8	5.8		5.3	5.3	5.3	
58.0	5.8	6.0	6.2	6.4	6.1	6.3	6.6	6.9	5.8	5.8	5.8		5.3	5.3	5.3	
62.0		5.8	5.9	6.1	5.9	6.0	6.2	6.5	5.8	5.8	5.8	5.8	5.3	5.3	5.3	
66.0			5.7	5.8			6.0	6.2		5.8	5.8	5.8		5.3	5.3	5.3
70.0								6.0			5.8	5.8			5.3	5.3
74.0											5.8	5.8				5.1
θ(°)	5~53	5~48	5~42	5~26	5~60	5~45	5~36	5~27	5~58	5~51	5~40	5~30	5~56	5~47	5~34	5~23
標準フック	11.3t															
フック質量	440kg															
標準巻掛本数	1															

注)カウンタウエイト 118t、アウトリガ張出幅 8.5m

●LB性能

2. 1m+47mラフィングジブ+17mエクステンションジブ

単位:t

ブーム長さ	35.3m				40.4m				45.4m			50.5m		
ブーム起伏角 作業半径(m)	83°	75°	65°	55°	83°	75°	65°	55°	83°	75°	65°	83°	75°	65°
28.0	4.6				3.4									
30.0	4.6				3.4				2.6					
32.0	4.6				3.4				2.6			1.9		
34.0	4.6				3.4				2.6			1.9		
36.0	4.6				3.4				2.6			1.9		
38.0	4.6				3.4				2.6			1.9		
40.0	4.6	4.6			3.4				2.6			1.9		
42.0	4.6	4.6			3.4	3.4			2.6			1.9		
44.0	4.6	4.6			3.4	3.4			2.6			1.9		
46.0	4.6	4.6			3.4	3.4			2.6	2.6		1.9		
48.0	4.6	4.6			3.4	3.4			2.6	2.6		1.9	1.9	
50.0	4.6	4.6			3.4	3.4			2.6	2.6		1.9	1.9	
54.0	4.6	4.6			3.4	3.4			2.6	2.6		1.9	1.9	
58.0	4.6	4.6	4.6		3.4	3.4	3.4		2.6	2.6		1.9	1.9	
62.0	4.6	4.6	4.6		3.4	3.4	3.4		2.6	2.6	2.6	1.9	1.9	
66.0		4.6	4.6			3.4	3.4			2.6	2.6		1.9	1.9
70.0			4.6	4.6		3.4	3.4			2.6	2.6		1.9	1.9
74.0			4.6	3.9			3.4	2.8			2.6			1.9
78.0				3.3				2.3			2.6			1.7
82.0								1.8						
θ(°)	5~54	5~43	5~38	5~25	5~51	5~48	5~32	5~26	5~48	5~43	5~34	5~46	5~39	5~29
標準フック	11.3t													
フック質量	440kg													
標準巻掛本数	1													

注)カウンタウエイト 118t、アウトリガ張出幅 8.5m

●LB性能

2. 1m+47mラフィングジブ+25mエクステンションジブ

単位:t

ブーム長さ	15.0m				20.1m				25.1m				30.2m			
ブーム起伏角 作業半径(m)	83°	75°	65°	55°	83°	75°	65°	55°	83°	75°	65°	55°	83°	75°	65°	55°
24.0	6.3				5.8											
26.0	6.3				5.8				3.6				3.3			
28.0	6.3				5.8				3.6				3.3			
30.0	6.3				5.8				3.6				3.3			
32.0	6.3				5.8				3.6				3.3			
34.0	6.3	6.3			5.8				3.6				3.3			
36.0	6.3	6.3			5.8	5.8			3.6				3.3			
38.0	6.3	6.3			5.8	5.8			3.6	3.6			3.3			
40.0	6.0	6.3			5.8	5.8			3.6	3.6			3.3	3.3		
42.0	5.7	6.1			5.8	5.8			3.6	3.6			3.3	3.3		
44.0	5.5	5.8			5.6	5.8			3.6	3.6			3.3	3.3		
46.0	5.2	5.5			5.3	5.7			3.6	3.6			3.3	3.3		
48.0	5.0	5.3	5.6		5.1	5.4			3.6	3.6			3.3	3.3		
50.0	4.8	5.0	5.3		4.9	5.2			3.6	3.6			3.3	3.3		
54.0	4.4	4.7	4.9		4.5	4.8	5.1		3.6	3.6	3.6		3.3	3.3		
58.0	4.1	4.3	4.5		4.2	4.4	4.7		3.6	3.6	3.6		3.3	3.3	3.3	
62.0	3.9	4.0	4.2	4.4	3.9	4.1	4.4		3.6	3.6	3.6		3.3	3.3	3.3	
66.0	3.6	3.8	3.9	4.1	3.7	3.9	4.1	4.3	3.6	3.6	3.6		3.3	3.3	3.3	
70.0		3.6	3.7	3.8	3.5	3.6	3.8	4.0	3.5	3.6	3.6	3.6	3.3	3.3	3.3	3.3
74.0		3.4	3.5	3.6		3.4	3.6	3.8		3.5	3.6	3.6	3.3	3.3	3.3	3.3
78.0				3.4				3.4	3.6			3.5	3.6		3.3	3.3
82.0								3.4				3.5			3.3	3.3
86.0															3.3	3.3
θ(°)	5~54	5~61	5~42	5~37	5~61	5~56	5~47	5~40	5~59	5~52	5~41	5~31	5~58	5~60	5~46	5~34
標準フック	11.3t															
フック質量	440kg															
標準巻掛本数	1															

注)カウンタウエイト 118t、アウトリガ張出幅 8.5m

●LB性能

2. 1m+47mラフィングジブ+25mエクステンションジブ

単位:t

ブーム長さ	35.3m				40.4m				45.4m			50.5m		
ブーム起伏角 作業半径(m)	83°	75°	65°	55°	83°	75°	65°	55°	83°	75°	65°	83°	75°	65°
28.0	3.0													
30.0	3.0				2.1									
32.0	3.0				2.1				1.6					
34.0	3.0				2.1				1.6			1.3		
36.0	3.0				2.1				1.6			1.3		
38.0	3.0				2.1				1.6			1.3		
40.0	3.0				2.1				1.6			1.3		
42.0	3.0	3.0			2.1				1.6			1.3		
44.0	3.0	3.0			2.1	2.1			1.6			1.3		
46.0	3.0	3.0			2.1	2.1			1.6			1.3		
48.0	3.0	3.0			2.1	2.1			1.6	1.6		1.3		
50.0	3.0	3.0			2.1	2.1			1.6	1.6		1.3	1.3	
54.0	3.0	3.0			2.1	2.1			1.6	1.6		1.3	1.3	
58.0	3.0	3.0			2.1	2.1			1.6	1.6		1.3	1.3	
62.0	3.0	3.0	3.0		2.1	2.1	2.1		1.6	1.6		1.3	1.3	
66.0	3.0	3.0	3.0		2.1	2.1	2.1		1.6	1.6	1.6	1.3	1.3	
70.0	3.0	3.0	3.0		2.1	2.1	2.1		1.6	1.6	1.6	1.3	1.3	1.3
74.0		3.0	3.0	3.0		2.1	2.1		1.6	1.6	1.6	1.3	1.3	1.3
78.0		3.0	3.0	3.0		2.1	2.1	2.1		1.6	1.6	1.3	1.3	1.3
82.0			3.0	2.9			2.1	1.8			1.6		1.3	
86.0				2.4				2.1			1.6			
90.0				2.0										
θ(°)	5~56	5~54	5~40	5~36	5~53	5~50	5~42	5~15	5~58	5~45	5~36	5~55	5~49	5~20
標準フック	11.3t													
フック質量	440kg													
標準巻掛本数	1													

注)カウンタウエイト 118t、アウトリガ張出幅 8.5m

●LC性能

2. 1m+4.7mラフィングジブ+9mエクステンションジブ

単位:t

ブーム長さ ブーム起伏角 作業半径(m)	15.0m				20.1m				25.1m				30.2m			
	83°	75°	65°	55°	83°	75°	65°	55°	83°	75°	65°	55°	83°	75°	65°	55°
18.0	16.8															
20.0	16.8				14.9				9.0							
22.0	16.8				14.9				9.0				7.9			
24.0	16.4				14.9				9.0				7.9			
26.0	15.8				14.9				9.0				7.9			
28.0	15.2	15.9			14.9				9.0				7.9			
30.0	14.6	15.3			14.8	14.9			9.0				7.9			
32.0	13.9	14.7			14.1	14.9			9.0	9.0			7.9			
34.0	13.2	14.0			13.4	14.5			9.0	9.0			7.9	7.9		
36.0	12.6	13.3			12.8	13.7			9.0	9.0			7.9	7.9		
38.0	12.0	12.7			12.2	13.1			9.0	9.0			7.9	7.9		
40.0	11.5	12.1	12.9		11.7	12.5			9.0	9.0			7.9	7.9		
42.0	11.0	11.6	12.3		11.2	11.9	12.9		9.0	9.0			7.9	7.9		
44.0	10.6	11.1	11.8		10.7	11.4	12.3		9.0	9.0	9.0		7.9	7.9		
46.0	10.2	10.7	11.3		10.3	11.0	11.8		9.0	9.0	9.0		7.9	7.9		
48.0	9.9	10.3	10.8	11.4	10.0	10.5	11.3		9.0	9.0	9.0		7.9	7.9	7.9	
50.0	9.6	9.9	10.4	10.9	9.7	10.2	10.9		9.0	9.0	9.0		7.9	7.9	7.9	
54.0			9.7	10.1		9.5	10.1	10.7		9.0	9.0			7.9	7.9	
58.0				9.5			9.5	10.0			9.0	9.0				7.9
62.0												8.5			7.9	6.8
66.0																5.9
θ(°)	5~52	5~39	5~32	5~25	5~50	5~45	5~36	5~19	5~49	5~41	5~31	5~21	5~47	5~38	5~34	5~22
標準フック	25t								11.3t							
フック質量	870kg								440kg							
標準巻掛本数	2								1							

注)カウンタウエイト 118t、アウトリガ張出幅 8.0m

●LC性能

2. 1m+4.7mラフィングジブ+9mエクステンションジブ

単位:t

ブーム長さ ブーム起伏角 作業半径(m)	35.3m				40.4m			45.4m			50.5m		
	83°	75°	65°	55°	83°	75°	65°	83°	75°	65°	83°	75°	65°
24.0	6.9												
26.0	6.9				5.1								
28.0	6.9				5.1			4.0					
30.0	6.9				5.1			4.0			2.7		
32.0	6.9				5.1			4.0			2.7		
34.0	6.9				5.1			4.0			2.7		
36.0	6.9	6.9			5.1			4.0			2.7		
38.0	6.9	6.9			5.1			4.0			2.7		
40.0	6.9	6.9			5.1	5.1		4.0			2.7		
42.0	6.9	6.9			5.1	5.1		4.0	4.0		2.7		
44.0	6.9	6.9			5.1	5.1		4.0	4.0		2.7	2.7	
46.0	6.9	6.9			5.1	5.1		4.0	4.0		2.7	2.7	
48.0	6.9	6.9			5.1	5.1		4.0	4.0		2.7	2.7	
50.0	6.9	6.9	6.9		5.1	5.1		4.0	4.0		2.7	2.7	
54.0		6.9	6.9		5.1	5.1	5.1	4.0	4.0		2.7	2.7	
58.0		6.9	6.9			5.1		4.0	4.0	4.0		2.7	
62.0			6.9				5.1			4.0		2.7	2.7
66.0				4.5			5.1			4.0			2.7
70.0				3.8									2.4
θ(°)	5~44	5~42	5~28	5~24	5~49	5~37	5~30	5~46	5~34	5~25	5~44	5~38	5~27
標準フック	11.3t												
フック質量	440kg												
標準巻掛本数	1												

注)カウンタウエイト 118t、アウトリガ張出幅 8.0m

●LC性能

2. 1m+4.7mラフィングジブ+17mエクステンションジブ

単位:t

ブーム長さ ブーム起伏角 作業半径(m)	15.0m				20.1m				25.1m				30.2m			
	83°	75°	65°	55°	83°	75°	65°	55°	83°	75°	65°	55°	83°	75°	65°	55°
22.0	9.8															
24.0	9.8				9.6				5.8							
26.0	9.8				9.6				5.8				5.3			
28.0	9.8				9.6				5.8				5.3			
30.0	9.3				9.6				5.8				5.3			
32.0	8.9	9.4			9.4				5.8				5.3			
34.0	8.5	9.0			9.0	9.6			5.8				5.3			
36.0	8.2	8.6			8.6	9.2			5.8	5.8			5.3			
38.0	7.9	8.2			8.3	8.8			5.8	5.8			5.3	5.3		
40.0	7.6	7.9			7.9	8.4			5.8	5.8			5.3	5.3		
42.0	7.3	7.6			7.7	8.1			5.8	5.8			5.3	5.3		
44.0	7.0	7.3	7.7		7.4	7.8			5.8	5.8			5.3	5.3		
46.0	6.8	7.1	7.4		7.1	7.5			5.8	5.8			5.3	5.3		
48.0	6.6	6.9	7.2		6.9	7.3	7.7		5.8	5.8			5.3	5.3		
50.0	6.4	6.6	6.9		6.7	7.0	7.5		5.8	5.8	5.8		5.3	5.3		
54.0	6.1	6.3	6.5		6.4	6.6	7.0		5.8	5.8	5.8		5.3	5.3	5.3	
58.0		5.8	6.2	6.4	6.1	6.3	6.6	6.9	5.8	5.8	5.8		5.3	5.3	5.3	
62.0			5.8	5.9	6.1	5.9	6.0	6.2	5.8	5.8	5.8	5.8	5.3	5.3	5.3	
66.0				5.7	5.8			6.0	6.2	5.8	5.8	5.8	5.3	5.3	5.3	5.3
70.0								6.0			5.8	5.8		5.3	5.3	5.3
74.0											5.8	5.8				4.9
θ(°)	5~53	5~48	5~42	5~26	5~60	5~45	5~36	5~27	5~58	5~51	5~40	5~30	5~56	5~47	5~34	5~23
標準フック	11.3t															
フック質量	440kg															
標準巻掛本数	1															

注)カウンタウエイト 118t、アウトリガ張出幅 8.0m

●LC性能

2. 1m+47mラフィンジブ+17mエクステンションジブ

単位:t

ブーム長さ	35.3m				40.4m				45.4m			50.5m		
ブーム起伏角 作業半径(m)	83°	75°	65°	55°	83°	75°	65°	55°	83°	75°	65°	83°	75°	65°
28.0	4.6				3.4									
30.0	4.6				3.4				2.6					
32.0	4.6				3.4				2.6			1.9		
34.0	4.6				3.4				2.6			1.9		
36.0	4.6				3.4				2.6			1.9		
38.0	4.6				3.4				2.6			1.9		
40.0	4.6	4.6			3.4				2.6			1.9		
42.0	4.6	4.6			3.4	3.4			2.6			1.9		
44.0	4.6	4.6			3.4	3.4			2.6			1.9		
46.0	4.6	4.6			3.4	3.4			2.6	2.6		1.9		
48.0	4.6	4.6			3.4	3.4			2.6	2.6		1.9	1.9	
50.0	4.6	4.6			3.4	3.4			2.6	2.6		1.9	1.9	
54.0	4.6	4.6			3.4	3.4			2.6	2.6		1.9	1.9	
58.0	4.6	4.6	4.6		3.4	3.4	3.4		2.6	2.6		1.9	1.9	
62.0	4.6	4.6	4.6		3.4	3.4	3.4		2.6	2.6	2.6	1.9	1.9	
66.0		4.6	4.6			3.4	3.4			2.6	2.6		1.9	1.9
70.0			4.6	4.3		3.4	3.4			2.6	2.6		1.9	1.9
74.0			4.6	3.7			3.4	2.5			2.6			1.9
78.0				3.1				2.0			2.6			1.7
82.0								1.5						
θ(°)	5~54	5~43	5~38	5~25	5~51	5~48	5~32	5~26	5~48	5~43	5~34	5~46	5~39	5~29
標準フック	11.3t													
フック質量	440kg													
標準巻掛本数	1													

注)カウンタウエイト 118t、アウトリガ張出幅 8.0m

●LC性能

2. 1m+47mラフィンジブ+25mエクステンションジブ

単位:t

ブーム長さ	15.0m				20.1m				25.1m				30.2m			
ブーム起伏角 作業半径(m)	83°	75°	65°	55°	83°	75°	65°	55°	83°	75°	65°	55°	83°	75°	65°	55°
24.0	6.3				5.8											
26.0	6.3				5.8				3.6				3.3			
28.0	6.3				5.8				3.6				3.3			
30.0	6.3				5.8				3.6				3.3			
32.0	6.3				5.8				3.6				3.3			
34.0	6.3	6.3			5.8				3.6				3.3			
36.0	6.3	6.3			5.8	5.8			3.6				3.3			
38.0	6.3	6.3			5.8	5.8			3.6	3.6			3.3	3.3		
40.0	6.0	6.3			5.8	5.8			3.6	3.6			3.3	3.3		
42.0	5.7	6.1			5.8	5.8			3.6	3.6			3.3	3.3		
44.0	5.5	5.8			5.6	5.8			3.6	3.6			3.3	3.3		
46.0	5.2	5.5			5.3	5.7			3.6	3.6			3.3	3.3		
48.0	5.0	5.3	5.6		5.1	5.4			3.6	3.6			3.3	3.3		
50.0	4.8	5.0	5.3		4.9	5.2			3.6	3.6			3.3	3.3		
54.0	4.4	4.7	4.9		4.5	4.8	5.1		3.6	3.6	3.6		3.3	3.3		
58.0	4.1	4.3	4.5		4.2	4.4	4.7		3.6	3.6	3.6		3.3	3.3	3.3	
62.0	3.9	4.0	4.2	4.4	3.9	4.1	4.4		3.6	3.6	3.6		3.3	3.3	3.3	
66.0	3.6	3.8	3.9	4.1	3.7	3.9	4.1	4.3	3.6	3.6	3.6		3.3	3.3	3.3	
70.0		3.6	3.7	3.8	3.5	3.6	3.8	4.0	3.5	3.6	3.6	3.6	3.3	3.3	3.3	3.3
74.0		3.4	3.5	3.6		3.4	3.6	3.8		3.5	3.6	3.6	3.3	3.3	3.3	3.3
78.0				3.4			3.4	3.6			3.5	3.6		3.3	3.3	3.3
82.0								3.4				3.5			3.3	3.3
86.0																3.2
θ(°)	5~54	5~61	5~42	5~37	5~61	5~56	5~47	5~40	5~59	5~52	5~41	5~31	5~58	5~60	5~46	5~34
標準フック	11.3t															
フック質量	440kg															
標準巻掛本数	1															

注)カウンタウエイト 118t、アウトリガ張出幅 8.0m

●LC性能

2. 1m+47mラフィンジブ+25mエクステンションジブ

単位:t

ブーム長さ	35.3m				40.4m				45.4m			50.5m		
ブーム起伏角 作業半径(m)	83°	75°	65°	55°	83°	75°	65°	55°	83°	75°	65°	83°	75°	65°
28.0	3.0													
30.0	3.0				2.1									
32.0	3.0				2.1				1.6					
34.0	3.0				2.1				1.6			1.3		
36.0	3.0				2.1				1.6			1.3		
38.0	3.0				2.1				1.6			1.3		
40.0	3.0				2.1				1.6			1.3		
42.0	3.0	3.0			2.1				1.6			1.3		
44.0	3.0	3.0			2.1	2.1			1.6			1.3		
46.0	3.0	3.0			2.1	2.1			1.6			1.3		
48.0	3.0	3.0			2.1	2.1			1.6	1.6		1.3		
50.0	3.0	3.0			2.1	2.1			1.6	1.6		1.3	1.3	
54.0	3.0	3.0			2.1	2.1			1.6	1.6		1.3	1.3	
58.0	3.0	3.0			2.1	2.1			1.6	1.6		1.3	1.3	
62.0	3.0	3.0	3.0		2.1	2.1	2.1		1.6	1.6		1.3	1.3	
66.0	3.0	3.0	3.0		2.1	2.1	2.1		1.6	1.6	1.6	1.3	1.3	
70.0	3.0	3.0	3.0		2.1	2.1	2.1		1.6	1.6	1.6	1.3	1.3	1.3
74.0		3.0	3.0	3.0		2.1	2.1		1.6	1.6	1.6	1.3	1.3	1.3
78.0		3.0	3.0	3.0		2.1	2.1	2.0		1.6	1.6	1.3	1.3	1.3
82.0			3.0	2.6			2.1	1.6			1.6		1.3	
86.0				2.2			2.1				1.6			
90.0				1.8										
θ(°)	5~56	5~54	5~40	5~36	5~53	5~50	5~42	5~15	5~58	5~45	5~36	5~55	5~49	5~20
標準フック	11.3t													
フック質量	440kg													
標準巻掛本数	1													

注)カウンタウエイト 118t、アウトリガ張出幅 8.0m

●LD性能

2. 1m+4.7mラフィングジブ+9mエクステンションジブ

単位:t

ブーム長さ	15.0m				20.1m				25.1m				30.2m			
ブーム起伏角 作業半径(m)	83°	75°	65°	55°	83°	75°	65°	55°	83°	75°	65°	55°	83°	75°	65°	55°
18.0	16.8															
20.0	16.8				14.9				9.0							
22.0	16.8				14.9				9.0				7.9			
24.0	16.4				14.9				9.0				7.9			
26.0	15.8				14.9				9.0				7.9			
28.0	15.2	15.9			14.9				9.0				7.9			
30.0	14.6	15.3			14.8	14.9			9.0				7.9			
32.0	13.9	14.7			14.1	14.9			9.0	9.0			7.9			
34.0	13.2	14.0			13.4	14.5			9.0	9.0			7.9	7.9		
36.0	12.6	13.3			12.8	13.7			9.0	9.0			7.9	7.9		
38.0	12.0	12.7			12.2	13.1			9.0	9.0			7.9	7.9		
40.0	11.5	12.1	12.9		11.7	12.5			9.0	9.0			7.9	7.9		
42.0	11.0	11.6	12.3		11.2	11.9	12.9		9.0	9.0			7.9	7.9		
44.0	10.6	11.1	11.8		10.7	11.4	12.3		9.0	9.0	9.0		7.9	7.9		
46.0	10.2	10.7	11.3		10.3	11.0	11.8		9.0	9.0	9.0		7.9	7.9		
48.0	9.9	10.3	10.8	11.4	10.0	10.5	11.3		9.0	9.0	9.0		7.9	7.9	7.9	
50.0	9.6	9.9	10.4	10.9	9.7	10.2	10.9		9.0	9.0	9.0		7.9	7.9	7.9	
54.0			9.7	10.1		9.5	10.1	9.8		9.0	9.0			7.9		
58.0				9.5				8.7				8.8	7.0			7.5
62.0													6.1			6.5
66.0																4.3
θ(°)	5~52	5~39	5~32	5~25	5~50	5~45	5~36	5~19	5~49	5~41	5~31	5~21	5~47	5~38	5~34	5~22
標準フック	25t								11.3t							
フック質量	870kg								440kg							
標準巻掛本数	2								1							

注)カウンタウエイト 98t、アウトリガ張出幅 8.5m
または、カウンタウエイト 98t、アウトリガ張出幅 8.0m

●LD性能

2. 1m+4.7mラフィングジブ+9mエクステンションジブ

単位:t

ブーム長さ	35.3m			40.4m			45.4m			50.5m		
ブーム起伏角 作業半径(m)	83°	75°	65°	83°	75°	65°	83°	75°	65°	83°	75°	65°
24.0	6.9											
26.0	6.9			5.1								
28.0	6.9			5.1			4.0					
30.0	6.9			5.1			4.0			2.7		
32.0	6.9			5.1			4.0			2.7		
34.0	6.9			5.1			4.0			2.7		
36.0	6.9	6.9		5.1			4.0			2.7		
38.0	6.9	6.9		5.1			4.0			2.7		
40.0	6.9	6.9		5.1	5.1		4.0			2.7		
42.0	6.9	6.9		5.1	5.1		4.0	4.0		2.7		
44.0	6.9	6.9		5.1	5.1		4.0	4.0		2.7	2.7	
46.0	6.9	6.9		5.1	5.1		4.0	4.0		2.7	2.7	
48.0	6.9	6.9		5.1	5.1		4.0	4.0		2.7	2.7	
50.0	6.9	6.9	6.9	5.1	5.1		4.0	4.0		2.7	2.7	
54.0		6.9	6.9	5.1	5.1	5.1	4.0	4.0		2.7	2.7	
58.0		6.9	6.2		5.1	5.1		4.0	4.0		2.7	
62.0			5.3			4.3			3.2		2.7	2.3
66.0						3.6			2.6			1.7
θ(°)	5~44	5~42	5~28	5~49	5~37	5~30	5~46	5~34	5~25	5~44	5~38	5~20
標準フック	11.3t						11.3t					
フック質量	440kg						440kg					
標準巻掛本数	1						1					

注)カウンタウエイト 98t、アウトリガ張出幅 8.5m
または、カウンタウエイト 98t、アウトリガ張出幅 8.0m

●LD性能

2. 1m+4.7mラフィングジブ+17mエクステンションジブ

単位:t

ブーム長さ	15.0m				20.1m				25.1m				30.2m			
ブーム起伏角 作業半径(m)	83°	75°	65°	55°	83°	75°	65°	55°	83°	75°	65°	55°	83°	75°	65°	55°
22.0	9.8															
24.0	9.8				9.6				5.8							
26.0	9.8				9.6				5.8				5.3			
28.0	9.8				9.6				5.8				5.3			
30.0	9.3				9.6				5.8				5.3			
32.0	8.9	9.4			9.4				5.8				5.3			
34.0	8.5	9.0			9.0	9.6			5.8				5.3			
36.0	8.2	8.6			8.6	9.2			5.8	5.8			5.3			
38.0	7.9	8.2			8.3	8.8			5.8	5.8			5.3	5.3		
40.0	7.6	7.9			7.9	8.4			5.8	5.8			5.3	5.3		
42.0	7.3	7.6			7.7	8.1			5.8	5.8			5.3	5.3		
44.0	7.0	7.3	7.7		7.4	7.8			5.8	5.8			5.3	5.3		
46.0	6.8	7.1	7.4		7.1	7.5			5.8	5.8			5.3	5.3		
48.0	6.6	6.9	7.2		6.9	7.3	7.7		5.8	5.8			5.3	5.3		
50.0	6.4	6.6	6.9		6.7	7.0	7.5		5.8	5.8	5.8		5.3	5.3		
54.0	6.1	6.3	6.5		6.4	6.6	7.0		5.8	5.8	5.8		5.3	5.3	5.3	
58.0		5.8	6.0	6.2	6.4	6.1	6.3	6.6	6.9	5.8	5.8	5.8	5.3	5.3	5.3	
62.0			5.8	5.9	6.1	5.9	6.0	6.2	6.5	5.8	5.8	5.8	5.8	5.3	5.3	5.3
66.0				5.7	5.8			6.0	6.2			5.8	5.8	5.7		4.1
70.0									6.0				5.8	4.9		3.4
74.0														4.2		2.8
θ(°)	5~53	5~48	5~42	5~26	5~60	5~45	5~36	5~27	5~58	5~51	5~40	5~30	5~56	5~47	5~34	5~23
標準フック	11.3t								11.3t							
フック質量	440kg								440kg							
標準巻掛本数	1								1							

注)カウンタウエイト 98t、アウトリガ張出幅 8.5m
または、カウンタウエイト 98t、アウトリガ張出幅 8.0m

●LD性能

2. 1m+47mラフィングジブ+17mエクステンションジブ

単位:t

ブーム長さ	35.3m				40.4m			45.4m			50.5m	
ブーム起伏角 作業半径(m)	83°	75°	65°	55°	83°	75°	65°	83°	75°	65°	83°	75°
28.0	4.6				3.4							
30.0	4.6				3.4			2.6				
32.0	4.6				3.4			2.6			1.9	
34.0	4.6				3.4			2.6			1.9	
36.0	4.6				3.4			2.6			1.9	
38.0	4.6				3.4			2.6			1.9	
40.0	4.6	4.6			3.4			2.6			1.9	
42.0	4.6	4.6			3.4	3.4		2.6			1.9	
44.0	4.6	4.6			3.4	3.4		2.6			1.9	
46.0	4.6	4.6			3.4	3.4		2.6	2.6		1.9	
48.0	4.6	4.6			3.4	3.4		2.6	2.6		1.9	1.9
50.0	4.6	4.6			3.4	3.4		2.6	2.6		1.9	1.9
54.0	4.6	4.6			3.4	3.4		2.6	2.6		1.9	1.9
58.0	4.6	4.6	4.6		3.4	3.4	3.4	2.6	2.6		1.9	1.9
62.0	4.6	4.6	4.6		3.4	3.4	3.4	2.6	2.6	2.6	1.9	1.9
66.0		4.6	4.6			3.4	3.4		2.6	2.6		1.9
70.0			4.3	2.1		3.4	3.4		2.6	2.3		1.9
74.0			3.7	1.6			2.8			1.8		
θ(°)	5~54	5~43	5~38	5~17	5~51	5~48	5~32	5~48	5~43	5~27	5~46	5~39
標準フック	11.3t											
フック質量	440kg											
標準巻掛本数	1											

注)カウンタウエイト 98t、アウトリガ張出幅 8.5m

または、カウンタウエイト 98t、アウトリガ張出幅 8.0m

●LD性能

2. 1m+47mラフィングジブ+25mエクステンションジブ

単位:t

ブーム長さ	15.0m				20.1m				25.1m				30.2m			
ブーム起伏角 作業半径(m)	83°	75°	65°	55°	83°	75°	65°	55°	83°	75°	65°	55°	83°	75°	65°	55°
24.0	6.3				5.8											
26.0	6.3				5.8				3.6				3.3			
28.0	6.3				5.8				3.6				3.3			
30.0	6.3				5.8				3.6				3.3			
32.0	6.3				5.8				3.6				3.3			
34.0	6.3	6.3			5.8				3.6				3.3			
36.0	6.3	6.3			5.8	5.8			3.6				3.3			
38.0	6.3	6.3			5.8	5.8			3.6	3.6			3.3			
40.0	6.0	6.3			5.8	5.8			3.6	3.6			3.3	3.3		
42.0	5.7	6.1			5.8	5.8			3.6	3.6			3.3	3.3		
44.0	5.5	5.8			5.6	5.8			3.6	3.6			3.3	3.3		
46.0	5.2	5.5			5.3	5.7			3.6	3.6			3.3	3.3		
48.0	5.0	5.3	5.6		5.1	5.4			3.6	3.6			3.3	3.3		
50.0	4.8	5.0	5.3		4.9	5.2			3.6	3.6			3.3	3.3		
54.0	4.4	4.7	4.9		4.5	4.8	5.1		3.6	3.6	3.6		3.3	3.3	3.3	
58.0	4.1	4.3	4.5		4.2	4.4	4.7		3.6	3.6	3.6		3.3	3.3	3.3	
62.0	3.9	4.0	4.2	4.4	3.9	4.1	4.4		3.6	3.6	3.6		3.3	3.3	3.3	
66.0	3.6	3.8	3.9	4.1	3.7	3.9	4.1	4.3	3.6	3.6	3.6		3.3	3.3	3.3	
70.0		3.6	3.7	3.8	3.5	3.6	3.8	4.0	3.5	3.6	3.6	3.6	3.3	3.3	3.3	3.3
74.0		3.4	3.5	3.6		3.4	3.6	3.8		3.5	3.6	3.6		3.3	3.3	2.8
78.0				3.4			3.4	3.6			3.5	3.6		3.3	3.3	2.3
82.0								3.4				3.2			3.3	1.9
86.0																1.5
θ(°)	5~54	5~61	5~42	5~37	5~61	5~56	5~47	5~40	5~59	5~52	5~41	5~31	5~58	5~60	5~46	5~34
標準フック	11.3t															
フック質量	440kg															
標準巻掛本数	1															

注)カウンタウエイト 98t、アウトリガ張出幅 8.5m

または、カウンタウエイト 98t、アウトリガ張出幅 8.0m

●LD性能

2. 1m+47mラフィングジブ+25mエクステンションジブ

単位:t

ブーム長さ	35.3m			40.4m			45.4m			50.5m	
ブーム起伏角 作業半径(m)	83°	75°	65°	83°	75°	65°	83°	75°	65°	83°	75°
28.0	3.0										
30.0	3.0			2.1							
32.0	3.0			2.1			1.6				
34.0	3.0			2.1			1.6			1.3	
36.0	3.0			2.1			1.6			1.3	
38.0	3.0			2.1			1.6			1.3	
40.0	3.0			2.1			1.6			1.3	
42.0	3.0	3.0		2.1			1.6			1.3	
44.0	3.0	3.0		2.1	2.1		1.6			1.3	
46.0	3.0	3.0		2.1	2.1		1.6			1.3	
48.0	3.0	3.0		2.1	2.1		1.6	1.6		1.3	
50.0	3.0	3.0		2.1	2.1		1.6	1.6		1.3	1.3
54.0	3.0	3.0		2.1	2.1		1.6	1.6		1.3	1.3
58.0	3.0	3.0		2.1	2.1		1.6	1.6		1.3	1.3
62.0	3.0	3.0	3.0	2.1	2.1	2.1	1.6	1.6		1.3	1.3
66.0	3.0	3.0	3.0	2.1	2.1	2.1	1.6	1.6	1.6	1.3	1.3
70.0	3.0	3.0	3.0	2.1	2.1	2.1	1.6	1.6	1.6	1.3	1.3
74.0		3.0	3.0		2.1	2.1	1.6	1.6	1.6	1.3	1.3
78.0		3.0	3.0		2.1	2.1		1.6			1.3
82.0			2.7								1.3
86.0											
θ(°)	5~56	5~54	5~40	5~53	5~50	5~42	5~58	5~45	5~19	5~55	5~49
標準フック	11.3t										
フック質量	440kg										
標準巻掛本数	1										

注)カウンタウエイト 98t、アウトリガ張出幅 8.5m

または、カウンタウエイト 98t、アウトリガ張出幅 8.0m

●LE性能

2. 1m+4.7mラフィングジブ+9mエクステンションジブ

単位:t

ブーム長さ	15.0m				20.1m				25.1m				30.2m			
ブーム起伏角 作業半径(m)	83°	75°	65°	55°	83°	75°	65°	55°	83°	75°	65°	55°	83°	75°	65°	
18.0	16.8															
20.0	16.8				14.9				9.0							
22.0	16.8				14.9				9.0				7.9			
24.0	16.4				14.9				9.0				7.9			
26.0	15.8				14.9				9.0				7.9			
28.0	15.2	15.9			14.9				9.0				7.9			
30.0	14.6	15.3			14.8	14.9			9.0				7.9			
32.0	13.9	14.7			14.1	14.9			9.0	9.0			7.9			
34.0	13.2	14.0			13.4	14.5			9.0	9.0			7.9	7.9		
36.0	12.6	13.3			12.8	13.7			9.0	9.0			7.9	7.9		
38.0	12.0	12.7			12.2	13.1			9.0	9.0			7.9	7.9		
40.0	11.5	12.1	12.9		11.7	12.5			9.0	9.0			7.9	7.9		
42.0	11.0	11.6	12.3		11.2	11.9	12.9		9.0	9.0			7.9	7.9		
44.0	10.6	11.1	11.8		10.7	11.4	12.0		9.0	9.0	9.0		7.9	7.9		
46.0	10.2	10.7	11.3		10.3	11.0	11.1		9.0	9.0	9.0		7.9	7.9		
48.0	9.9	10.3	10.8	10.4	10.0	10.5	10.4		9.0	9.0	9.0		7.9	7.9	7.5	
50.0	9.6	9.9	10.4	9.7	9.7	10.2	9.7		9.0	9.0	8.5		7.9	7.9	6.8	
54.0			9.4	8.5		9.5	8.5	7.1		9.0	7.3			7.9	5.7	
58.0				7.4				6.0				6.2	4.4		4.8	
62.0												3.6			4.0	
θ(°)	5~52	5~39	5~32	5~25	5~50	5~45	5~36	5~19	5~49	5~41	5~31	5~21	5~47	5~38	5~34	
標準フック	25t								11.3t							
フック質量	870kg								440kg							
標準巻掛本数	2								1							

注)カウンタウエイト 78t、アウトリガ張出幅 8.5m
または、カウンタウエイト 78t、アウトリガ張出幅 8.0m

●LE性能

2. 1m+4.7mラフィングジブ+9mエクステンションジブ

単位:t

ブーム長さ	35.3m			40.4m			45.4m		50.5m	
ブーム起伏角 作業半径(m)	83°	75°	65°	83°	75°	65°	83°	75°	83°	75°
24.0	6.9									
26.0	6.9			5.1						
28.0	6.9			5.1			4.0			
30.0	6.9			5.1			4.0		2.7	
32.0	6.9			5.1			4.0		2.7	
34.0	6.9			5.1			4.0		2.7	
36.0	6.9	6.9		5.1			4.0		2.7	
38.0	6.9	6.9		5.1			4.0		2.7	
40.0	6.9	6.9		5.1	5.1		4.0		2.7	
42.0	6.9	6.9		5.1	5.1		4.0	4.0	2.7	
44.0	6.9	6.9		5.1	5.1		4.0	4.0	2.7	2.7
46.0	6.9	6.9		5.1	5.1		4.0	4.0	2.7	2.7
48.0	6.9	6.9		5.1	5.1		4.0	4.0	2.7	2.7
50.0	6.9	6.9	5.3	5.1	5.1		4.0	4.0	2.7	2.7
54.0		6.9	4.3	5.1	5.1	3.2	4.0	4.0	2.7	2.7
58.0		6.4	3.5		5.1	2.5		4.0		2.7
62.0			2.8			1.8				2.7
θ(°)	5~44	5~42	5~28	5~49	5~37	5~23	5~46	5~34	5~44	5~38
標準フック	11.3t									
フック質量	440kg									
標準巻掛本数	1									

注)カウンタウエイト 78t、アウトリガ張出幅 8.5m
または、カウンタウエイト 78t、アウトリガ張出幅 8.0m

6. TRA+ESPブーム定格総荷重表

1. 定格総荷重表の性能区分TA～TFは、下表のとおりです。

カウンタウエイト アウトリガ 張出幅	138 t	118 t	98 t	78 t	58 t
8.5m	TA	TB	TD	TE	TF
8.0m		TC	TD	TE	TF
6.8m				TF	

2. 定格総荷重は、つり具質量とフック質量（170トフック：3,200 kg、80トフック：1,270 kg、11.3トフック：440 kg）を含んだ値を示します。
3. 定格総荷重は、ブームのたわみを含んだ実際の作業半径に基づいています。
4. 各ブーム長さにおける各ブーム段の伸長状態（伸長割合%）は、下表のとおりです。

ブーム長さ	35.3m	40.4m	45.4m	50.5m	55.6m	60.0m
伸縮ブーム1	90	90	90	90	90	100
伸縮ブーム2	90	90	90	90	90	100
伸縮ブーム3	0	45	90	90	90	100
伸縮ブーム4	0	0	0	45	90	100

5. ブーム長さ 35.3m未満での性能設定はありません。また、Bピン（ブーム固定ピン）を挿入していない状態では使用できません。
6. 定格総荷重表中の標準巻掛本数より少ない本数で使用する場合、最大荷重の上限は下表のとおりです。

巻掛本数	9本	8本	7本	6本	5本	4本	3本	1本
最大荷重	94.7t	85.0t	75.1t	65.0t	54.7t	44.2t	33.5t	11.3t

7. シングルトップ使用時の巻掛本数は1本（11.3トフック使用）で、定格総荷重はブームの定格総荷重からブームに取り付けられているフックの質量を差し引いた値とし、かつ上限は11.3tです。
8. 定格総荷重は、アウトリガを水平堅土上に設置したときの値です。
9. 定格総荷重表は、風による影響を含んでいません。瞬間最大風速が10m/s以上の風速では、クレーン作業を中止してください。
10. 定格総荷重表中の太線より上側はクレーンの強度に、下側はクレーンの安定に基づいています。
11. 「 θ (°)」は、無負荷状態で作動可能なブーム起伏角度範囲を示します。
12. 「補巻時・標準巻掛本数」は、補巻使用時の標準巻掛本数を示します。
13. 「主巻時・標準巻掛本数」は、主巻使用時の標準巻掛本数を示し、補巻よりもワイヤロープ長さが短いため、巻掛本数が少なくなる場合があります。
14. 「主巻時・最大荷重」は、主巻使用時の定格総荷重の上限を示します。

■TA性能

TRA+ESPブーム

単位:t

ブーム長さ(m) 作業半径(m)	35.3	40.4	45.4	50.5	55.6	60.0
10.0	96.4	75.0				
11.0	88.9	75.0	65.0	51.0	41.6	32.4
12.0	82.4	75.0	65.0	51.0	41.6	32.4
14.0	71.1	71.3	65.0	51.0	41.5	32.4
16.0	62.2	62.6	62.4	49.4	41.5	32.4
18.0	54.9	55.4	55.4	46.9	41.5	32.4
20.0	48.7	49.5	49.6	44.8	39.9	32.0
22.0	43.3	44.4	44.7	42.8	38.0	30.5
24.0	38.4	40.0	40.5	41.0	36.4	29.1
26.0	33.8	35.9	36.7	37.4	34.9	27.8
28.0	29.2	32.3	33.4	34.2	33.6	26.6
30.0	24.1	28.7	30.3	31.3	31.9	25.6
32.0	17.6	25.2	27.4	28.7	29.4	24.7
34.0		21.5	24.7	26.3	27.2	23.2
36.0		17.0	21.9	24.0	25.1	21.4
38.0		9.8	19.0	21.7	23.1	19.6
40.0			15.8	19.5	21.2	18.1
42.0			11.5	17.2	19.4	16.7
44.0				14.7	17.5	15.4
46.0				11.7	15.7	14.2
48.0				6.9	13.7	13.1
50.0					11.4	12.1
52.0					8.3	10.8
54.0						9.0
56.0						6.7
θ(°)	0~76	0~77	0~78	0~80	0~81	0~81
標準フック	170t	80t	80t	80t	80t	80t
フック質量	3200kg	1270kg	1270kg	1270kg	1270kg	1270kg
補巻時・標準巻掛本数	11	7	6	5	4	3
主巻時・標準巻掛本数	8	6	6	5	4	3
主巻時・最大荷重	85.0	65.0	65.0	51.0	41.6	32.4

注)カウンタウエイト 138t、アウトリガ張出幅 8.5m

■TB性能

TRA+ESPブーム

単位:t

ブーム長さ(m) 作業半径(m)	35.3	40.4	45.4	50.5	55.6	60.0
7.0	109.8					
8.0	109.8	75.0	65.0	51.0	41.8	
9.0	105.0	75.0	65.0	51.0	41.7	32.4
10.0	96.4	75.0	65.0	51.0	41.7	32.4
11.0	88.9	75.0	65.0	51.0	41.6	32.4
12.0	82.4	75.0	65.0	51.0	41.6	32.4
14.0	71.1	71.3	65.0	51.0	41.5	32.4
16.0	62.2	62.6	62.4	49.4	41.5	32.4
18.0	54.0	55.2	55.4	46.9	41.5	32.4
20.0	47.4	48.6	49.4	44.8	39.9	32.0
22.0	41.9	43.2	44.0	42.8	38.0	30.5
24.0	36.5	37.9	38.9	40.0	36.4	29.1
26.0	32.0	33.4	34.3	35.4	34.9	27.8
28.0	28.2	29.6	30.5	31.6	32.4	26.6
30.0	24.1	26.3	27.3	28.3	29.2	25.6
32.0	17.6	23.5	24.5	25.5	26.4	24.7
34.0		21.1	22.0	23.1	23.9	23.2
36.0		17.0	19.9	20.9	21.8	21.4
38.0		9.8	18.0	19.0	19.9	19.6
40.0			15.8	17.3	18.2	18.1
42.0			11.5	15.8	16.6	16.7
44.0				14.4	15.3	15.4
46.0				11.7	14.0	14.2
48.0				6.9	12.9	13.1
50.0					11.4	12.1
52.0					8.3	10.8
54.0						9.0
56.0						6.7
θ(°)	0~81	0~81	0~82	0~83	0~84	0~84
標準フック	170t	80t	80t	80t	80t	80t
フック質量	3200kg	1270kg	1270kg	1270kg	1270kg	1270kg
補巻時・標準巻掛本数	11	7	6	5	4	3
主巻時・標準巻掛本数	8	6	6	5	4	3
主巻時・最大荷重	85.0	65.0	65.0	51.0	41.8	32.4

注)カウンタウエイト 118t、アウトリガ張出幅 8.5m

■TC性能

TRA+ESPブーム

単位:t

ブーム長さ(m) 作業半径(m)	35.3	40.4	45.4	50.5	55.6	60.0
7.0	109.8					
8.0	109.8	75.0	65.0	51.0		
9.0	105.0	75.0	65.0	51.0	41.7	32.4
10.0	96.4	75.0	65.0	51.0	41.7	32.4
11.0	88.9	75.0	65.0	51.0	41.6	32.4
12.0	82.4	75.0	65.0	51.0	41.6	32.4
14.0	70.9	71.3	65.0	51.0	41.5	32.4
16.0	60.8	62.0	62.4	49.4	41.5	32.4
18.0	52.8	54.0	54.8	46.9	41.5	32.4
20.0	46.3	47.5	48.3	44.8	39.9	32.0
22.0	40.9	42.1	42.9	42.8	38.0	30.5
24.0	36.4	37.6	38.4	39.3	36.4	29.1
26.0	32.0	33.4	34.3	35.4	34.9	27.8
28.0	28.2	29.6	30.5	31.6	32.4	26.6
30.0	24.1	26.3	27.3	28.3	29.2	25.6
32.0	17.6	23.5	24.5	25.5	26.4	24.7
34.0		21.1	22.0	23.1	23.9	23.2
36.0		17.0	19.9	20.9	21.8	21.4
38.0		9.8	18.0	19.0	19.9	19.6
40.0			15.8	17.3	18.2	18.1
42.0			11.5	15.8	16.6	16.7
44.0				14.4	15.3	15.4
46.0				11.7	14.0	14.2
48.0				6.9	12.9	13.1
50.0					11.4	12.1
52.0					8.3	10.8
54.0						9.0
56.0						6.7
θ(°)	0~80	0~81	0~82	0~83	0~83	0~84
標準フック	170t	80t	80t	80t	80t	80t
フック質量	3200kg	1270kg	1270kg	1270kg	1270kg	1270kg
補巻時・標準巻掛本数	11	7	6	5	4	3
主巻時・標準巻掛本数	8	6	6	5	4	3
主巻時・最大荷重	85.0	65.0	65.0	51.0	41.7	32.4

注)カウンタウエイト 118t、アウトリガ張出幅 8.0m

■TD性能

TRA+ESPブーム

単位:t

ブーム長さ(m) 作業半径(m)	35.3	40.4	45.4	50.5	55.6	60.0
5.0	109.8					
6.0	109.8	75.0				
7.0	109.8	75.0	65.0			
8.0	109.8	75.0	65.0	51.0	41.8	
9.0	105.0	75.0	65.0	51.0	41.7	32.4
10.0	96.4	75.0	65.0	51.0	41.7	32.4
11.0	87.8	75.0	65.0	51.0	41.6	32.4
12.0	79.9	75.0	65.0	51.0	41.6	32.4
14.0	67.2	68.4	65.0	51.0	41.5	32.4
16.0	57.4	58.6	59.4	49.4	41.5	32.4
18.0	49.1	50.7	51.7	46.9	41.5	32.4
20.0	41.5	43.0	44.0	44.8	39.9	32.0
22.0	35.5	36.9	37.9	39.0	38.0	30.5
24.0	30.6	32.1	33.0	34.1	35.0	29.1
26.0	26.6	28.0	29.0	30.0	30.9	27.8
28.0	23.3	24.7	25.6	26.6	27.5	26.6
30.0	20.4	21.8	22.7	23.8	24.6	24.9
32.0	17.6	19.3	20.2	21.3	22.1	22.4
34.0		17.1	18.1	19.1	20.0	20.2
36.0		15.2	16.2	17.2	18.1	18.3
38.0		9.8	14.5	15.5	16.4	16.6
40.0			13.0	14.0	14.9	15.1
42.0			11.5	12.7	13.5	13.8
44.0				11.5	12.3	12.5
46.0				10.4	11.2	11.4
48.0				6.9	10.2	10.4
50.0					9.3	9.5
52.0					8.3	8.6
54.0						7.7
56.0						6.7
θ(°)	0~84	0~84	0~84.5	0~84.5	0~84.5	0~84.5
標準フック	170t	80t	80t	80t	80t	80t
フック質量	3200kg	1270kg	1270kg	1270kg	1270kg	1270kg
補巻時・標準巻掛本数	11	7	6	5	4	3
主巻時・標準巻掛本数	8	6	6	5	4	3
主巻時・最大荷重	85.0	65.0	65.0	51.0	41.8	32.4

注)カウンタウエイト 98t、アウトリガ張出幅 8.5m

または、カウンタウエイト 98t、アウトリガ張出幅 8.0m

■TE性能

TRA+ESPブーム

単位:t

ブーム長さ(m) 作業半径(m)	35.3	40.4	45.4	50.5	55.6	60.0
5.0	109.8					
6.0	109.8	75.0				
7.0	109.8	75.0	65.0			
8.0	109.8	75.0	65.0	51.0	41.8	
9.0	102.8	75.0	65.0	51.0	41.7	32.4
10.0	92.1	75.0	65.0	51.0	41.7	32.4
11.0	83.1	75.0	65.0	51.0	41.6	32.4
12.0	75.5	75.0	65.0	51.0	41.6	32.4
14.0	61.6	63.2	64.3	51.0	41.5	32.4
16.0	49.6	51.2	52.3	49.4	41.5	32.4
18.0	40.9	42.4	43.4	44.6	41.5	32.4
20.0	34.2	35.7	36.7	37.8	38.8	32.0
22.0	29.0	30.5	31.4	32.5	33.5	30.5
24.0	24.8	26.2	27.2	28.2	29.1	29.1
26.0	21.3	22.7	23.6	24.7	25.6	25.9
28.0	18.4	19.8	20.7	21.7	22.6	22.9
30.0	15.9	17.2	18.2	19.2	20.1	20.4
32.0	13.7	15.1	16.0	17.0	17.9	18.2
34.0		13.2	14.1	15.2	16.0	16.3
36.0		11.5	12.5	13.5	14.3	14.6
38.0		9.7	11.0	12.0	12.9	13.1
40.0			9.4	10.7	11.5	11.8
42.0			8.1	9.4	10.4	10.6
44.0				8.2	9.2	9.5
46.0				7.1	8.1	8.4
48.0				6.0	7.1	7.4
50.0					6.2	6.5
52.0					5.3	5.6
54.0						4.8
56.0						4.1
$\theta(^{\circ})$	0 ~ 84.5	0 ~ 84.5	0 ~ 84.5	0 ~ 84.5	0 ~ 84.5	0 ~ 84.5
標準フック	170t	80t	80t	80t	80t	80t
フック質量	3200kg	1270kg	1270kg	1270kg	1270kg	1270kg
補巻時・標準巻掛本数	11	7	6	5	4	3
主巻時・標準巻掛本数	8	6	6	5	4	3
主巻時・最大荷重	85.0	65.0	65.0	51.0	41.8	32.4

注)カウンタウエイト 78t、アウトリガ張出幅 8.5m
または、カウンタウエイト 78t、アウトリガ張出幅 8.0m

■TF性能

TRA+ESPブーム

単位:t

ブーム長さ(m) 作業半径(m)	35.3	40.4	45.4	50.5	55.6	60.0
7.0	109.8					
8.0	109.4	75.0	65.0			
9.0	96.9	75.0	65.0	51.0	41.7	32.4
10.0	86.6	75.0	65.0	51.0	41.7	32.4
11.0	75.4	75.0	65.0	51.0	41.6	32.4
12.0	65.1	66.9	65.0	51.0	41.6	32.4
14.0	50.3	52.0	53.0	51.0	41.5	32.4
16.0	40.1	41.7	42.7	43.9	41.5	32.4
18.0	32.7	34.2	35.2	36.4	37.3	32.4
20.0	27.0	28.5	29.5	30.6	31.5	31.8
22.0	22.5	24.0	25.0	26.1	27.0	27.3
24.0	18.9	20.4	21.3	22.4	23.3	23.6
26.0	15.9	17.3	18.3	19.3	20.2	20.5
28.0	13.3	14.7	15.7	16.7	17.6	17.9
30.0	10.8	12.6	13.5	14.6	15.4	15.7
32.0	8.7	10.4	11.6	12.7	13.5	13.8
34.0		8.6	9.8	11.0	11.9	12.2
36.0		6.9	8.1	9.5	10.5	10.7
38.0		5.4	6.7	8.0	9.1	9.4
40.0			5.4	6.7	7.8	8.1
42.0			4.2	5.6	6.6	6.9
44.0				4.5	5.6	5.9
46.0				3.6	4.7	5.0
48.0				2.7	3.8	4.1
50.0					3.0	3.3
52.0					2.3	2.6
$\theta(^{\circ})$	0 ~ 80	0 ~ 80	0 ~ 82	0 ~ 82	0 ~ 83	0 ~ 84
標準フック	170t	80t	80t	80t	80t	80t
フック質量	3200kg	1270kg	1270kg	1270kg	1270kg	1270kg
補巻時・標準巻掛本数	11	7	6	5	4	3
主巻時・標準巻掛本数	8	6	6	5	4	3
主巻時・最大荷重	85.0	65.0	65.0	51.0	41.7	32.4

注)カウンタウエイト 78t、アウトリガ張出幅 6.8m
または、カウンタウエイト 58t、アウトリガ張出幅 8.5m
または、カウンタウエイト 58t、アウトリガ張出幅 8.0m

7. TRA+フルオートラフィングジブ定格総荷重表

1. 定格総荷重表の性能区分TFA~TFGは、下表のとおりです。

カウンタウェイト アウトリガ 張出幅	138 t	118 t	98 t	78 t	58 t	47 t
8.5m	TFA	TFB	TFD	TFE	TFF	TFG
8.0m		TFC	TFD	TFE	TFF	TFG
6.8m				TFE	TFG	

2. 定格総荷重は、つり具質量とフック質量（80トンフック：1,270 kg、25トンフック：870 kg、11.3トンフック：440 kg）を含んだ値を示します。
3. 定格総荷重は、ブームのたわみを含んだ実際の作業半径に基づいています。
4. 各ブーム長さにおける各ブーム段の伸長状態（伸長割合%）は、下表のとおりです。

ブーム長さ	40.4m	45.4m	50.5m	55.6m	60.0m
伸縮ブーム1	90	90	90	90	100
伸縮ブーム2	90	90	90	90	100
伸縮ブーム3	45	90	90	90	100
伸縮ブーム4	0	0	45	90	100

5. ブーム長さ 40.4m未満での性能設定はありません。また、Bピン（ブーム固定ピン）を挿入していない状態では使用できません。
6. 定格総荷重表中の標準巻掛本数より少ない本数で使用する場合、最大荷重の上限は下表のとおりです。

掛数	3本	2本	1本
最大荷重	33.5 t	22.5 t	11.3 t

7. 定格総荷重は、アウトリガを水平堅土上に設置したときの値です。
8. 定格総荷重表は、風による影響を含んでいません。瞬間最大風速が 10m/s 以上の風速では、クレーン作業を中止してください。
9. 定格総荷重表中の太線より上側はクレーンの強度に、下側はクレーンの安定に基づいています。
10. 「 θ (°)」は、無負荷状態で作動可能なブーム起伏角度範囲を示します。

「オフセット」は下図のようにブームの中心線とジブの中心線とのなす角度を示します。

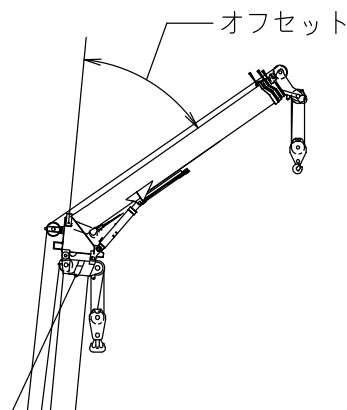

■TFA性能
TRA+40. 4mブーム+1. 6m+フルオートラフィングジブ 単位:t

ジブ長さ(m)	10.3m					17.2m					24.1m					31.0m				
	オフセット					オフセット					オフセット					オフセット				
作業半径(m)	5°	15°	30°	45°	60°	5°	15°	30°	45°	60°	5°	15°	30°	45°	60°	5°	15°	30°	45°	60°
9.0	37.6																			
10.0	37.5					16.7														
11.0	37.4	38.1				16.7														
12.0	37.3	38.0				16.7														
14.0	37.2	37.8	30.0	25.5		16.7	16.7				16.4									
16.0	37.2	36.0	28.7	24.7	22.7	16.7	16.7				16.0					10.9				
18.0	37.1	33.9	27.5	24.0	22.3	16.7	16.7	16.7			15.6	14.2				10.9				
20.0	35.2	32.1	26.4	23.4	22.0	16.7	16.7	16.7	14.9		15.2	13.7				10.7				
22.0	33.5	30.5	25.5	22.8	21.8	16.7	16.7	16.7	14.4	13.1	14.8	13.3				10.5	9.8			
24.0	31.7	29.0	24.6	22.4	21.6	16.7	16.7	16.2	14.0	12.9	14.3	12.9	11.5			10.3	9.4			
26.0	28.4	27.7	23.9	21.9	21.4	16.7	16.7	15.6	13.7	12.7	13.8	12.5	11.1			10.1	9.0			
28.0	25.4	26.0	23.2	21.6		16.7	16.7	15.1	13.3	12.5	13.3	12.1	10.8	9.6		9.9	8.6	7.3		
30.0	22.5	23.1	22.6	21.3		16.7	16.7	14.6	13.0	12.4	12.9	11.8	10.5	9.3	8.5	9.5	8.3	7.1		
32.0	19.9	20.4	21.1	21.0		16.7	16.2	14.1	12.8	12.3	12.5	11.5	10.2	9.1	8.4	9.1	8.0	6.8		
34.0	17.4	18.0	18.6	18.9		16.6	15.6	13.7	12.5	12.2	12.2	11.2	9.9	8.9	8.2	8.7	7.7	6.6	6.0	
36.0	15.2	15.7	16.3	16.4		15.7	15.0	13.3	12.3		11.8	10.9	9.7	8.7	8.1	8.4	7.4	6.4	5.8	
38.0	13.0	13.6	14.1			14.9	14.4	13.0	12.2		11.3	10.5	9.4	8.5	8.1	8.1	7.2	6.2	5.7	5.2
40.0	10.9	11.5	11.9			14.2	13.9	12.7	12.1		10.7	10.3	9.2	8.3	8.0	7.8	6.9	6.1	5.6	5.1
42.0	8.8	9.4	9.7			12.5	13.4	12.4	12.0		10.1	9.9	8.9	8.2		7.5	6.7	5.9	5.4	5.1
44.0	6.6	7.1				10.8	11.7	12.2			9.6	9.5	8.7	8.1		7.2	6.5	5.8	5.3	5.0
46.0	4.2	4.7				9.1	10.1	10.7			9.2	9.1	8.5	8.0		7.0	6.3	5.6	5.2	5.0
48.0						7.4	8.4	9.0			8.7	8.8	8.3	7.9		6.8	6.1	5.5	5.1	5.0
50.0						5.7	6.8	7.2			8.3	8.5	8.1			6.6	6.0	5.4	5.1	
54.0							2.8				6.4	7.3	7.9			6.2	5.7	5.2	4.9	
58.0											3.5	4.5				5.7	5.4	5.0		
62.0																4.7	5.2	4.9		
66.0																2.2	3.2			
θ(°)	27~83	28~83	39~83	51~83	67~83	32~83	26~83	39~83	53~83	66~83	30~83	33~83	44~83	55~83	67~83	28~83	31~83	43~83	57~83	67~83
標準フック	80t					25t					11.3t									
フック質量	1270kg					870kg					440kg									
標準巻掛本数	4					2					1									

注)カウンタウエイト 138t、アウトリガ張出幅 8.5m

■TFA性能
TRA+45. 4mブーム+1. 6m+フルオートラフィングジブ 単位:t

ジブ長さ(m)	10.3m					17.2m					24.1m					31.0m				
	オフセット					オフセット					オフセット					オフセット				
作業半径(m)	5°	15°	30°	45°	60°	5°	15°	30°	45°	60°	5°	15°	30°	45°	60°	5°	15°	30°	45°	60°
9.0	28.2																			
10.0	28.1					16.7														
11.0	28.0	28.6				16.7														
12.0	27.9	28.5				16.7														
14.0	27.8	27.7	25.2			16.7	16.7				15.5									
16.0	27.8	26.0	23.8	22.3	21.3	16.7	16.7				15.2					10.6				
18.0	26.2	24.5	22.5	21.2	20.3	16.7	16.7				14.9	14.0				10.4				
20.0	24.7	23.1	21.4	20.3	19.5	16.7	16.7	16.7			14.6	13.6				10.2				
22.0	23.3	21.9	20.4	19.4	18.8	16.7	16.7	16.7	14.6		14.3	13.2				10.0	9.6			
24.0	22.1	20.8	19.5	18.6	18.1	16.7	16.7	16.2	14.2	12.9	14.0	12.8				9.8	9.3			
26.0	21.0	19.9	18.7	17.9	17.5	16.7	16.7	15.5	13.8	12.7	13.7	12.4	11.0			9.7	8.9			
28.0	20.0	19.0	17.9	17.3	16.9	16.7	16.1	14.8	13.5	12.6	13.3	12.1	10.7			9.5	8.6			
30.0	19.2	18.2	17.3	16.7		16.5	15.4	14.2	13.2	12.4	12.9	11.8	10.4	9.5		9.3	8.3	7.0		
32.0	18.4	17.5	16.7	16.2		15.7	14.8	13.7	13.0	12.3	12.6	11.5	10.2	9.2	8.4	9.1	8.0	6.8		
34.0	17.5	16.9	16.1	15.7		15.1	14.2	13.2	12.6	12.2	12.2	11.2	9.9	9.0	8.3	8.8	7.7	6.6	5.9	
36.0	15.5	16.0	15.6	15.3		14.5	13.6	12.8	12.3	12.1	11.9	10.9	9.7	8.8	8.2	8.4	7.4	6.4	5.8	
38.0	13.5	14.0	14.5	14.7		13.9	13.2	12.4	11.9		11.6	10.6	9.5	8.6	8.1	8.2	7.2	6.3	5.7	5.3
40.0	11.7	12.1	12.6			13.4	12.7	12.0	11.6		11.3	10.3	9.3	8.5	8.0	7.9	7.0	6.1	5.6	5.2
42.0	9.9	10.3	10.8			12.7	12.3	11.6	11.3		10.9	10.1	9.1	8.3	8.0	7.6	6.8	5.9	5.4	5.1
44.0	8.2	8.6	9.0			11.2	11.9	11.3	11.1		10.4	9.8	8.9	8.2		7.4	6.6	5.8	5.3	5.1
46.0	6.5	6.8	7.2			9.8	10.4	11.0	10.8		9.9	9.6	8.7	8.1		7.1	6.4	5.7	5.2	5.0
48.0	4.7	5.0				8.4	9.0	9.7			9.5	9.3	8.5	8.0		6.9	6.2	5.5	5.1	5.0
50.0	2.7	3.0				7.0	7.7	8.2			9.0	9.0	8.4	7.9		6.7	6.1	5.4	5.1	5.0
54.0						4.3	4.9	5.3			6.9	7.7	7.9			6.3	5.8	5.2	4.9	
58.0											4.6	5.5	6.2			6.0	5.5	5.0	4.8	
62.0											2.2	3.1				5.1	5.3	4.9		
66.0																3.2	4.1	4.8		
70.0																	2.0			
θ(°)	29~84	30~84	39~84	53~84	67~84	35~84	37~84	38~84	53~84	67~84	31~84	34~84	44~84	57~84	68~84	36~84	33~84	43~84	56~84	68~84
標準フック	80t					25t					11.3t									
フック質量	1270kg					870kg					440kg									
標準巻掛本数	4					2					1									

注)カウンタウエイト 138t、アウトリガ張出幅 8.5m

■TFA性能 TRA+50. 6mブーム+1. 6m+フルオートラフィングジブ 単位:t

ジブ長さ(m)	10.3m					17.2m					24.1m					31.0m						
	オフセット					オフセット					オフセット					オフセット						
作業半径(m)	5°	15°	30°	45°	60°	5°	15°	30°	45°	60°	5°	15°	30°	45°	60°	5°	15°	30°	45°	60°		
10.0	21.0																					
11.0	20.9																					
12.0	20.9	19.2																				
14.0	20.3	17.9	15.5																			
16.0	19.0	16.9	14.7	13.3											12.2							
18.0	17.8	15.9	14.0	12.7	12.0										12.2					9.0		
20.0	16.7	15.0	13.3	12.2	11.6	13.8	12.1								11.7	10.1				9.0		
22.0	15.8	14.3	12.7	11.8	11.2	13.0	11.4	9.8	8.8						11.0	9.5				8.9		
24.0	14.9	13.6	12.2	11.3	10.9	12.3	10.8	9.4	8.5	7.9					10.4	9.0	7.7			8.9		
26.0	14.2	13.0	11.7	11.0	10.6	11.6	10.3	9.0	8.2	7.7					9.8	8.6	7.3			8.8		
28.0	13.5	12.4	11.3	10.6	10.3	11.0	9.8	8.6	7.9	7.4					9.3	8.2	7.0			8.3		
30.0	12.9	11.9	10.9	10.3	10.1	10.5	9.4	8.3	7.6	7.2					8.8	7.8	6.7	5.9		7.9		
32.0	12.3	11.4	10.5	10.0	9.8	10.0	9.0	8.0	7.4	7.0					8.4	7.5	6.5	5.7	5.1	7.5		
34.0	11.9	11.0	10.2	9.8		9.5	8.6	7.7	7.2	6.8					8.0	7.1	6.2	5.4	4.9	7.2		
36.0	11.4	10.6	9.9	9.5		9.1	8.3	7.5	6.9	6.6					7.6	6.8	5.9	5.2	4.8	6.8		
38.0	11.0	10.3	9.6	9.3		8.8	8.0	7.2	6.6	6.4					7.3	6.6	5.6	5.0	4.6	6.5		
40.0	10.6	10.0	9.4	9.1		8.4	7.7	7.0	6.4						7.0	6.2	5.3	4.8	4.4	6.2		
42.0	10.3	9.7	9.2	9.0		8.1	7.5	6.7	6.2						6.7	5.9	5.1	4.6	4.3	6.0		
44.0	9.0	9.4	9.0			7.8	7.2	6.5	6.1						6.4	5.6	4.9	4.4	4.2	5.6		
46.0	7.5	7.9	8.2			7.5	6.9	6.2	5.9						6.1	5.4	4.7	4.2		5.3		
48.0	6.0	6.4	6.7			7.3	6.6	6.0	5.8						5.8	5.1	4.5	4.1		5.0		
50.0	4.5	4.9	5.2			7.0	6.4	5.9							5.5	4.9	4.3	4.0		4.8		
54.0						5.1	5.7	5.6							5.0	4.5	4.0	3.7		4.3		
58.0						2.7	3.3	3.7							4.6	4.2	3.7			3.9		
62.0															3.3	3.9	3.6			3.5		
66.0																1.9				3.2		
70.0																				2.1		
θ(°)	37~84.5	38~84.5	39~84.5	52~84.5	66~84.5	35~84.5	36~84.5	39~84.5	54~84.5	67~84.5	38~84.5	35~84.5	44~84.5	56~84.5	68~84.5	37~84.5	40~84.5	43~84.5	60~84.5	70~84.5		
標準フック																25t						11.3t
フック質量																870kg						440kg
標準巻掛本数																2						1

注)カウンタウエイト 138t、アウトリガ張出幅 8.5m

■TFA性能 TRA+55. 6mブーム+1. 6m+フルオートラフィングジブ 単位:t

ジブ長さ(m)	10.3m					17.2m					24.1m					31.0m						
	オフセット					オフセット					オフセット					オフセット						
作業半径(m)	5°	15°	30°	45°	60°	5°	15°	30°	45°	60°	5°	15°	30°	45°	60°	5°	15°	30°	45°	60°		
11.0	15.0																					
12.0	15.0																					
14.0	14.9	15.2																				
16.0	14.9	15.0	13.3																			
18.0	14.8	14.1	12.6	11.6	11.0															6.8		
20.0	14.2	13.3	12.0	11.1	10.5	11.6	10.9	9.4												6.7		
22.0	13.1	12.6	11.4	10.6	10.0	11.5	10.3	9.0												6.7		
24.0	12.1	11.9	10.9	10.1	9.5	10.9	9.7	8.4	7.5											6.7		
26.0	11.1	11.0	10.4	9.6	9.1	10.3	9.2	7.9	7.1	6.5										6.7		
28.0	10.3	10.2	9.9	9.2	8.7	9.7	8.7	7.5	6.7	6.2										7.0		
30.0	9.5	9.4	9.4	8.7	8.4	9.0	8.2	7.1	6.4	5.9										6.7		
32.0	8.8	8.7	8.7	8.3	8.0	8.4	7.7	6.7	6.0	5.6										6.7		
34.0	8.2	8.1	8.1	8.0		7.8	7.2	6.3	5.7	5.4										6.7		
36.0	7.6	7.5	7.5	7.5		7.2	6.8	6.0	5.5	5.2										6.7		
38.0	7.0	7.0	6.9	7.0		6.7	6.4	5.7	5.2	5.0										6.7		
40.0	6.5	6.5	6.4	6.5		6.2	6.1	5.4	5.0	4.8										6.7		
42.0	6.1	6.0	6.0	6.0		5.8	5.7	5.1	4.8											6.7		
44.0	5.7	5.6	5.6	5.6		5.4	5.3	4.9	4.6											6.7		
46.0	5.3	5.2	5.2			5.0	5.0	4.7	4.4											6.7		
48.0	4.9	4.9	4.8			4.6	4.6	4.4	4.2											6.7		
50.0	4.6	4.6	4.6			4.3	4.3	4.3	4.0											6.7		
54.0	3.2	3.5	3.7			3.8	3.7	3.7												6.7		
58.0						3.3	3.3	3.2												6.7		
62.0																				6.7		
66.0																				6.7		
70.0																				6.7		
θ(°)	38~84.5	39~84.5	40~84.5	54~84.5	68~84.5	41~84.5	37~84.5	45~84.5	56~84.5	68~84.5	40~84.5	42~84.5	44~84.5	55~84.5	69~84.5	43~84.5	46~84.5	49~84.5	59~84.5	72~84.5		
標準フック																25t						11.3t
フック質量																870kg						440kg
標準巻掛本数																2						1

注)カウンタウエイト 138t、アウトリガ張出幅 8.5m

■TFA性能 TRA+60. 0mブーム+1. 6m+フルオートラフィングジブ 単位:t

ジブ長さ(m)	10.3m					17.2m					24.1m					31.0m						
	オフセット					オフセット					オフセット					オフセット						
作業半径(m)	5°	15°	30°	45°	60°	5°	15°	30°	45°	60°	5°	15°	30°	45°	60°	5°	15°	30°	45°	60°		
12.0	11.5																					
14.0	11.4	11.7																				
16.0	11.4	11.7	12.3																			
18.0	11.4	11.6	11.7	10.8																		
20.0	11.4	11.6	11.1	10.3	9.6																	
22.0	11.4	11.6	10.6	9.8	9.1																	
24.0	10.6	10.6	10.1	9.2	8.7																	
26.0	9.7	9.7	9.5	8.8	8.3																	
28.0	8.9	8.9	8.9	8.3	7.9																	
30.0	8.1	8.1	8.1	7.9	7.5																	
32.0	7.4	7.4	7.4	7.5	7.2																	
34.0	6.8	6.8	6.8	6.8	6.9																	
36.0	6.2	6.2	6.2	6.2																		
38.0	5.5	5.6	5.6	5.7																		
40.0	4.3	4.9	5.1	5.2																		
42.0	3.2	3.7	4.4	4.7																		
44.0	2.1	2.6	3.2	3.4																		
46.0																						
48.0																						
50.0																						
54.0																						
58.0																						
62.0																						
θ(°)	55~84.5	56~84.5	55~84.5	68~84.5		54~84.5	56~84.5	54~84.5	55~84.5	67~84.5	55~84.5	58~84.5	57~84.5	58~84.5	69~84.5	56~84.5	56~84.5	60~84.5	62~84.5	70~84.5		
標準フック																25t						11.3t
フック質量																870kg						440kg
標準巻掛本数																2						1

注)カウンタウエイト 138t、アウトリガ張出幅 8.5m

■TFB性能 TRA+40. 4mブーム+1. 6m+フルオートラフィングジブ 単位:t

作業半径(m)	10.3m					17.2m					24.1m					31.0m				
	オフセット					オフセット					オフセット					オフセット				
ジブ長さ(m)	5°	15°	30°	45°	60°	5°	15°	30°	45°	60°	5°	15°	30°	45°	60°	5°	15°	30°	45°	60°
9.0	37.6																			
10.0	37.5	38.3				16.7														
11.0	37.4	38.1				16.7														
12.0	37.3	38.0				16.7					16.7									
14.0	37.2	37.8	30.0	25.5		16.7	16.7				16.4					10.9				
16.0	37.2	36.0	28.7	24.7	22.7	16.7	16.7				16.0					10.9				
18.0	37.1	33.9	27.5	24.0	22.3	16.7	16.7	16.7			15.6	14.2				10.9				
20.0	35.2	32.1	26.4	23.4	22.0	16.7	16.7	16.7	14.9		15.2	13.7				10.7				
22.0	33.5	30.5	25.5	22.8	21.8	16.7	16.7	16.7	14.4	13.1	14.8	13.3				10.5	9.8			
24.0	31.5	29.0	24.6	22.4	21.6	16.7	16.7	16.2	14.0	12.9	14.3	12.9	11.5			10.3	9.4			
26.0	27.6	27.7	23.9	21.9	21.4	16.7	16.7	15.6	13.7	12.7	13.8	12.5	11.1			10.1	9.0			
28.0	24.3	25.0	23.2	21.6		16.7	16.7	15.1	13.3	12.5	13.3	12.1	10.8	9.6		9.9	8.6	7.3		
30.0	21.1	21.8	22.6	21.3		16.7	16.7	14.6	13.0	12.4	12.9	11.8	10.5	9.3	8.5	9.5	8.3	7.1		
32.0	18.2	18.9	19.6	20.0		16.7	16.2	14.1	12.8	12.3	12.5	11.5	10.2	9.1	8.4	9.1	8.0	6.8		
34.0	15.7	16.3	16.9	17.1		16.6	15.6	13.7	12.5	12.2	12.2	11.2	9.9	8.9	8.2	8.7	7.7	6.6	6.0	
36.0	13.5	14.0	14.5	14.6		15.7	15.0	13.3	12.3		11.8	10.9	9.7	8.7	8.1	8.4	7.4	6.4	5.8	
38.0	11.5	11.9	12.3			14.2	14.4	13.0	12.2		11.3	10.5	9.4	8.5	8.1	8.1	7.2	6.2	5.7	5.2
40.0	9.5	10.0	10.4			12.4	13.1	12.7	12.1		10.7	10.3	9.2	8.3	8.0	7.8	6.9	6.1	5.6	5.1
42.0	7.7	8.1	8.3			10.8	11.5	12.2	12.0		10.1	9.9	8.9	8.2		7.5	6.7	5.9	5.4	5.1
44.0	6.0	6.3				9.3	9.9	10.6			9.6	9.5	8.7	8.1		7.2	6.5	5.8	5.3	5.0
46.0	4.2	4.7				7.7	8.4	9.0			9.2	9.1	8.5	8.0		7.0	6.3	5.6	5.2	5.0
48.0						6.3	6.9	7.4			8.7	8.8	8.3	7.9		6.8	6.1	5.5	5.1	5.0
50.0						5.0	5.5	5.8			7.4	8.3	8.1			6.6	6.0	5.4	5.1	
54.0							2.8				5.1	5.8	6.5			6.2	5.7	5.2	4.9	
58.0											3.2	3.6				5.3	5.4	5.0		
62.0																3.6	4.2	4.9		
66.0																2.0	2.4			
θ(°)	27~84.5	28~84.5	39~84.5	51~84.5	67~84.5	32~84.5	26~84.5	39~84.5	53~84.5	66~84.5	30~84.5	33~84.5	44~84.5	55~84.5	67~84.5	28~84.5	31~84.5	43~84.5	57~84.5	67~84.5
標準フック	80t					25t					11.3t									
フック質量	1270kg					870kg					440kg									
標準巻掛本数	4					2					1									

注)カウンタウエイト 118t、アウトリガ張出幅 8.5m

■TFB性能 TRA+45. 4mブーム+1. 6m+フルオートラフィングジブ 単位:t

作業半径(m)	10.3m					17.2m					24.1m					31.0m				
	オフセット					オフセット					オフセット					オフセット				
ジブ長さ(m)	5°	15°	30°	45°	60°	5°	15°	30°	45°	60°	5°	15°	30°	45°	60°	5°	15°	30°	45°	60°
9.0	28.2																			
10.0	28.1					16.7														
11.0	28.0	28.6				16.7														
12.0	27.9	28.5				16.7	16.7													
14.0	27.8	27.7	25.2			16.7	16.7				15.5									
16.0	27.8	26.0	23.8	22.3	21.3	16.7	16.7				15.2					10.6				
18.0	26.2	24.5	22.5	21.2	20.3	16.7	16.7				14.9	14.0				10.4				
20.0	24.7	23.1	21.4	20.3	19.5	16.7	16.7	16.7			14.6	13.6				10.2				
22.0	23.3	21.9	20.4	19.4	18.8	16.7	16.7	16.7	14.6		14.3	13.2				10.0	9.6			
24.0	22.1	20.8	19.5	18.6	18.1	16.7	16.7	16.2	14.2	12.9	14.0	12.8				9.8	9.3			
26.0	21.0	19.9	18.7	17.9	17.5	16.7	16.7	15.5	13.8	12.7	13.7	12.4	11.0			9.7	8.9			
28.0	20.0	19.0	17.9	17.3	16.9	16.7	16.1	14.8	13.5	12.6	13.3	12.1	10.7			9.5	8.6			
30.0	19.2	18.2	17.3	16.7		16.5	15.4	14.2	13.2	12.4	12.9	11.8	10.4	9.5		9.3	8.3	7.0		
32.0	18.4	17.5	16.7	16.2		15.7	14.8	13.7	13.0	12.3	12.6	11.5	10.2	9.2	8.4	9.1	8.0	6.8		
34.0	15.9	16.5	16.1	15.7		15.1	14.2	13.2	12.6	12.2	12.2	11.2	9.9	9.0	8.3	8.8	7.7	6.6	5.9	
36.0	13.7	14.2	14.8	15.1		14.5	13.6	12.8	12.3	12.1	11.9	10.9	9.7	8.8	8.2	8.4	7.4	6.4	5.8	
38.0	11.7	12.2	12.7	12.9		13.9	13.2	12.4	11.9		11.6	10.6	9.5	8.6	8.1	8.2	7.2	6.3	5.7	5.3
40.0	9.8	10.4	10.8			12.4	12.7	12.0	11.6		11.3	10.3	9.3	8.5	8.0	7.9	7.0	6.1	5.6	5.2
42.0	8.0	8.5	8.9			10.8	11.6	11.6	11.3		10.9	10.1	9.1	8.3	8.0	7.6	6.8	5.9	5.4	5.1
44.0	6.3	6.7	7.1			9.3	10.1	10.8	11.1		10.4	9.8	8.9	8.2		7.4	6.6	5.8	5.3	5.1
46.0	4.8	5.2	5.4			7.8	8.6	9.3	9.6		9.9	9.6	8.7	8.1		7.1	6.4	5.7	5.2	5.0
48.0	3.5	3.7				6.4	7.1	7.8			8.6	9.3	8.5	8.0		6.9	6.2	5.5	5.1	5.0
50.0		2.4				5.1	5.7	6.3			7.3	8.3	8.4	7.9		6.7	6.1	5.4	5.1	5.0
54.0						2.8	3.3	3.6			5.1	5.8	6.7			6.3	5.8	5.2	4.9	
58.0											3.1	3.7	4.3			5.1	5.5	5.0	4.8	
62.0																3.4	4.2	4.9		
66.0																1.9	2.5	3.1		
θ(°)	29~84.5	30~84.5	39~84.5	53~84.5	67~84.5	35~84.5	37~84.5	38~84.5	53~84.5	67~84.5	37~84.5	41~84.5	44~84.5	57~84.5	68~84.5	36~84.5	40~84.5	43~84.5	56~84.5	68~84.5
標準フック	80t					25t					11.3t									
フック質量	1270kg					870kg					440kg									
標準巻掛本数	4					2					1									

注)カウンタウエイト 118t、アウトリガ張出幅 8.5m

■TFB性能 TRA+50. 6mブーム+1. 6m+フルオートラフィングジブ 単位:t

ジブ長さ(m)	10.3m					17.2m					24.1m					31.0m							
	オフセット					オフセット					オフセット					オフセット							
作業半径(m)	5°	15°	30°	45°	60°	5°	15°	30°	45°	60°	5°	15°	30°	45°	60°	5°	15°	30°	45°	60°			
10.0	21.0																						
11.0	20.9																						
12.0	20.9	19.2				15.9																	
14.0	20.3	17.9	15.5			15.8																	
16.0	19.0	16.9	14.7	13.3		15.8	13.5							12.2									
18.0	17.8	15.9	14.0	12.7	12.0	14.7	12.8							12.2				9.0					
20.0	16.7	15.0	13.3	12.2	11.6	13.8	12.1	10.3						11.7	10.1			9.0					
22.0	15.8	14.3	12.7	11.8	11.2	13.0	11.4	9.8	8.8					11.0	9.5			8.9					
24.0	14.9	13.6	12.2	11.3	10.9	12.3	10.8	9.4	8.5	7.9				10.4	9.0	7.7		8.9	8.0				
26.0	14.2	13.0	11.7	11.0	10.6	11.6	10.3	9.0	8.2	7.7				9.8	8.6	7.3		8.8	7.6				
28.0	13.5	12.4	11.3	10.6	10.3	11.0	9.8	8.6	7.9	7.4				9.3	8.2	7.0		8.3	7.3				
30.0	12.9	11.9	10.9	10.3	10.1	10.5	9.4	8.3	7.6	7.2				8.8	7.8	6.7	5.9	7.9	6.9	5.9			
32.0	12.3	11.4	10.5	10.0	9.8	10.0	9.0	8.0	7.4	7.0				8.4	7.5	6.5	5.7	5.1	7.5	6.6	5.6		
34.0	11.9	11.0	10.2	9.8		9.5	8.6	7.7	7.2	6.8				8.0	7.1	6.2	5.4	4.9	7.2	6.3	5.3		
36.0	11.4	10.6	9.9	9.5		9.1	8.3	7.5	6.9	6.6				7.6	6.8	5.9	5.2	4.8	6.8	6.0	5.1	4.4	
38.0	11.0	10.3	9.6	9.3		8.8	8.0	7.2	6.6	6.4				7.3	6.6	5.6	5.0	4.6	6.5	5.8	4.8	4.2	
40.0	10.3	10.0	9.4	9.1		8.4	7.7	7.0	6.4					7.0	6.2	5.3	4.8	4.4	6.2	5.5	4.6	4.0	3.6
42.0	8.5	9.0	9.2	9.0		8.1	7.5	6.7	6.2					6.7	5.9	5.1	4.6	4.3	6.0	5.2	4.3	3.8	3.4
44.0	6.8	7.3	7.8			7.8	7.2	6.5	6.1					6.4	5.6	4.9	4.4	4.2	5.6	4.9	4.1	3.6	3.3
46.0	5.3	5.7	6.1			7.5	6.9	6.2	5.9					6.1	5.4	4.7	4.2		5.3	4.6	3.9	3.5	3.2
48.0	4.0	4.3	4.6			6.7	6.6	6.0	5.8					5.8	5.1	4.5	4.1		5.0	4.4	3.7	3.3	3.1
50.0	2.7	3.0	3.2			5.4	6.1	5.9						5.5	4.9	4.3	4.0		4.8	4.2	3.6	3.2	3.0
54.0						3.2	3.7	4.2						5.0	4.5	4.0	3.7		4.3	3.8	3.2	2.9	
58.0								1.9						3.2	3.9	3.7			3.9	3.4	3.0	2.7	
62.0															2.1	2.7			3.4	3.1	2.7		
66.0																			1.9	2.6	2.5		
70.0																					1.7		
θ(°)	37~84.5	38~84.5	39~84.5	52~84.5	66~84.5	41~84.5	43~84.5	39~84.5	54~84.5	67~84.5	44~84.5	41~84.5	44~84.5	56~84.5	68~84.5	42~84.5	45~84.5	43~84.5	60~84.5	70~84.5			
標準フック																25t						11.3t	
フック質量																870kg						440kg	
標準巻掛本数																2						1	

注)カウンタウエイト 118t、アウトリガ張出幅 8.5m

■TFB性能 TRA+55. 6mブーム+1. 6m+フルオートラフィングジブ 単位:t

ジブ長さ(m)	10.3m					17.2m					24.1m					31.0m								
	オフセット					オフセット					オフセット					オフセット								
作業半径(m)	5°	15°	30°	45°	60°	5°	15°	30°	45°	60°	5°	15°	30°	45°	60°	5°	15°	30°	45°	60°				
11.0	15.0																							
12.0	15.0																							
14.0	14.9	15.2				11.7																		
16.0	14.9	15.0	13.3			11.6									8.8									
18.0	14.8	14.1	12.6	11.6	11.0	11.6	11.5								8.8				6.8					
20.0	14.2	13.3	12.0	11.1	10.5	11.6	10.9	9.4							8.8				6.7					
22.0	13.1	12.6	11.4	10.6	10.0	11.5	10.3	9.0							8.8	9.0			6.7					
24.0	12.1	11.9	10.9	10.1	9.5	10.9	9.7	8.4	7.5						8.8	8.5			6.7					
26.0	11.1	11.0	10.4	9.6	9.1	10.3	9.2	7.9	7.1	6.5					8.8	8.1	6.8		6.7	7.0				
28.0	10.3	10.2	9.9	9.2	8.7	9.7	8.7	7.5	6.7	6.2					8.6	7.6	6.4		6.7	6.7				
30.0	9.5	9.4	9.4	8.7	8.4	9.0	8.2	7.1	6.4	5.9					8.0	7.2	6.0		6.7	6.2				
32.0	8.8	8.7	8.7	8.3	8.0	8.4	7.7	6.7	6.0	5.6					7.5	6.7	5.7	5.0	6.7	5.8	4.8			
34.0	8.2	8.1	8.1	8.0		7.8	7.2	6.3	5.7	5.4					6.9	6.3	5.4	4.7	4.3	6.3	5.4	4.5		
36.0	7.6	7.5	7.5	7.5		7.2	6.8	6.0	5.5	5.2					6.5	5.9	5.1	4.5	4.1	5.9	5.1	4.3		
38.0	7.0	7.0	6.9	7.0		6.7	6.4	5.7	5.2	5.0					6.0	5.6	4.8	4.3	3.9	5.5	4.8	3.5		
40.0	6.5	6.5	6.4	6.5		6.2	6.1	5.4	5.0	4.8					5.6	5.2	4.5	4.0	3.7	5.1	4.5	3.8	3.3	
42.0	6.1	6.0	6.0	6.0		5.8	5.7	5.1	4.8						5.2	4.9	4.3	3.8	3.6	4.8	4.2	3.5	3.1	
44.0	5.7	5.6	5.6	5.6		5.4	5.3	4.9	4.6						4.9	4.7	4.0	3.6	3.4	4.5	3.9	3.3	2.9	2.7
46.0	5.3	5.2	5.2			5.0	5.0	4.7	4.4						4.5	4.4	3.8	3.5	3.3	4.2	3.7	3.1	2.8	2.5
48.0	4.6	4.9	4.8			4.6	4.6	4.4	4.2						4.2	4.1	3.6	3.3		3.9	3.5	2.9	2.6	2.4
50.0	3.4	3.7	4.0			4.3	4.3	4.3	4.0						3.9	3.9	3.4	3.1		3.7	3.2	2.8	2.5	2.3
54.0						3.4	3.7	3.7							3.4	3.4	3.1	2.9		3.2	2.9	2.4	2.2	
58.0							2.0	2.4							2.9	2.9	2.8	2.6		2.8	2.5	2.2	1.9	
62.0															1.9	2.5	2.5			2.4	2.2	1.9	1.7	
66.0																				2.0	2.0	1.7		
70.0																						1.5		
θ(°)	44~84.5	45~84.5	46~84.5	54~84.5	68~84.5	46~84.5	43~84.5	45~84.5	56~84.5	68~84.5	44~84.5	47~84.5	49~84.5	55~84.5	69~84.5	47~84.5	50~84.5	49~84.5	59~84.5	72~84.5				
標準フック																25t						11.3t		
フック質量																870kg						440kg		
標準巻掛本数																2						1		

注)カウンタウエイト 118t、アウトリガ張出幅 8.5m

■TFB性能 TRA+60. 0mブーム+1. 6m+フルオートラフィングジブ 単位:t

ジブ長さ(m)	10.3m					17.2m					24.1m					31.0m							
	オフセット					オフセット					オフセット					オフセット							
作業半径(m)	5°	15°	30°	45°	60°	5°	15°	30°	45°	60°	5°	15°	30°	45°	60°	5°	15°	30°	45°	60°			
12.0	11.5																						
14.0	11.4	11.7				8.7																	
16.0	11.4	11.7	12.3			8.7																	
18.0	11.4	11.6	11.7	10.8		8.7	9.0								6.8								
20.0	11.4	11.6	11.1	10.3	9.6	8.6	8.9								6.8					5.3			
22.0	11.4	11.6	10.6	9.8	9.1	8.6	8.9	8.6							6.8	7.1				5.3			
24.0	10.6	10.6	10.1	9.2	8.7	8.6	8.8	8.1							6.8	7.0				5.3			
26.0	9.7	9.7	9.5	8.8	8.3	8.6	8.6	7.6	6.8						6.8	7.0				5.3	5.3		
28.0	8.9	8.9	8.9	8.3	7.9	7.9	8.0	7.2	6.4	5.9					6.8	7.0	5.9			5.3	5.3		
30.0	8.1	8.1	8.1	7.9	7.5	7.3	7.3	6.8	6.1	5.6					6.8	6.6	5.6			5.3	5.3		
32.0	7.4	7.4	7.4	7.5	7.2	6.7	6.7	6.4	5.8	5.4					6.5	6.2	5.2	4.6		5.3	5.3		
34.0	6.8	6.8	6.8	6.8	6.9	6.2	6.2	6.1	5.5	5.1					6.0	5.8	4.9	4.3		5.3	5.0	4.2	
36.0	6.2	6.2	6.2	6.2		5.6	5.7	5.7	5.2	4.9					5.5	5.4	4.6	4.1		5.3	4.7	3.9	
38.0	5.5	5.6	5.6	5.7		5.2	5.2	5.3	4.9	4.7					5.0	5.1	4.4	3.9	3.6	4.9	4.4	3.7	
40.0	4.3	4.9	5.1	5.2		4.7	4.8	4.9	4.7	4.5					4.6	4.7	4.1	3.7	3.4	4.5	4.1	3.4</	

■TFC性能

TRA+40. 4mブーム+1. 6m+フルオートラフィングジブ

単位:t

ジブ長さ(m)	10.3m					17.2m					24.1m					31.0m				
	オフセット					オフセット					オフセット					オフセット				
作業半径(m)	5°	15°	30°	45°	60°	5°	15°	30°	45°	60°	5°	15°	30°	45°	60°	5°	15°	30°	45°	60°
9.0	37.6																			
10.0	37.5	38.3				16.7														
11.0	37.4	38.1				16.7														
12.0	37.3	38.0				16.7					16.7									
14.0	37.2	37.8	30.0	25.5		16.7	16.7				16.4					10.9				
16.0	37.2	36.0	28.7	24.7	22.7	16.7	16.7				16.0					10.9				
18.0	37.1	33.9	27.5	24.0	22.3	16.7	16.7	16.7			15.6	14.2				10.9				
20.0	35.2	32.1	26.4	23.4	22.0	16.7	16.7	16.7	14.9		15.2	13.7				10.7				
22.0	33.5	30.5	25.5	22.8	21.8	16.7	16.7	16.7	14.4	13.1	14.8	13.3				10.5	9.8			
24.0	30.6	29.0	24.6	22.4	21.6	16.7	16.7	16.2	14.0	12.9	14.3	12.9	11.5			10.3	9.4			
26.0	26.8	27.6	23.9	21.9	21.4	16.7	16.7	15.6	13.7	12.7	13.8	12.5	11.1			10.1	9.0			
28.0	23.5	24.2	23.2	21.6		16.7	16.7	15.1	13.3	12.5	13.3	12.1	10.8	9.6		9.9	8.6	7.3		
30.0	20.6	21.3	22.0	21.3		16.7	16.7	14.6	13.0	12.4	12.9	11.8	10.5	9.3	8.5	9.5	8.3	7.1		
32.0	18.1	18.7	19.3	19.7		16.7	16.2	14.1	12.8	12.3	12.5	11.5	10.2	9.1	8.4	9.1	8.0	6.8		
34.0	15.7	16.3	16.9	17.1		16.6	15.6	13.7	12.5	12.2	11.2	9.9	8.9	8.2	8.7	7.7	6.6	6.0		
36.0	13.5	14.0	14.5	14.6		15.7	15.0	13.3	12.3		11.8	10.9	9.7	8.7	8.1	8.4	7.4	6.4	5.8	
38.0	11.2	11.7	12.3			14.2	14.4	13.0	12.2		11.3	10.5	9.4	8.5	8.1	8.1	7.2	6.2	5.7	5.2
40.0	9.1	9.6	10.0			12.4	13.1	12.7	12.1		10.7	10.3	9.2	8.3	8.0	7.8	6.9	6.1	5.6	5.1
42.0	7.3	7.7	7.9			10.6	11.5	12.2	12.0		10.1	9.9	8.9	8.2		7.5	6.7	5.9	5.4	5.1
44.0	5.6	5.9				8.9	9.7	10.5			9.6	9.5	8.7	8.1		7.2	6.5	5.8	5.3	5.0
46.0	4.1	4.3				7.4	8.0	8.7			9.2	9.1	8.5	8.0		7.0	6.3	5.6	5.2	5.0
48.0						6.0	6.5	7.0			8.4	8.8	8.3	7.9		6.8	6.1	5.5	5.1	5.0
50.0						4.7	5.1	5.4			7.1	8.0	8.1			6.6	6.0	5.4	5.1	
54.0							2.6				4.8	5.5	6.2			6.2	5.7	5.2	4.9	
58.0											2.8	3.3				5.0	5.4	5.0		
62.0																3.3	3.9	4.6		
66.0																1.7	2.2			
θ(°)	27~84.5	28~84.5	39~84.5	51~84.5	67~84.5	32~84.5	26~84.5	39~84.5	53~84.5	66~84.5	30~84.5	33~84.5	44~84.5	55~84.5	67~84.5	28~84.5	31~84.5	43~84.5	57~84.5	67~84.5
標準フック	80t					25t					11.3t									
フック質量	1270kg					870kg					440kg									
標準巻掛本数	4					2					1									

注)カウンタウエイト 118t、アウトリガ張出幅 8.0m

■TFC性能

TRA+45. 4mブーム+1. 6m+フルオートラフィングジブ

単位:t

ジブ長さ(m)	10.3m					17.2m					24.1m					31.0m				
	オフセット					オフセット					オフセット					オフセット				
作業半径(m)	5°	15°	30°	45°	60°	5°	15°	30°	45°	60°	5°	15°	30°	45°	60°	5°	15°	30°	45°	60°
9.0	28.2																			
10.0	28.1					16.7														
11.0	28.0	28.6				16.7														
12.0	27.9	28.5				16.7	16.7													
14.0	27.8	27.7	25.2			16.7	16.7				15.5									
16.0	27.8	26.0	23.8	22.3	21.3	16.7	16.7				15.2					10.6				
18.0	26.2	24.5	22.5	21.2	20.3	16.7	16.7				14.9	14.0				10.4				
20.0	24.7	23.1	21.4	20.3	19.5	16.7	16.7	16.7			14.6	13.6				10.2				
22.0	23.3	21.9	20.4	19.4	18.8	16.7	16.7	16.7	14.6		14.3	13.2				10.0	9.6			
24.0	22.1	20.8	19.5	18.6	18.1	16.7	16.7	16.2	14.2	12.9	14.0	12.8				9.8	9.3			
26.0	21.0	19.9	18.7	17.9	17.5	16.7	16.7	15.5	13.8	12.7	13.7	12.4	11.0			9.7	8.9			
28.0	20.0	19.0	17.9	17.3	16.9	16.7	16.1	14.8	13.5	12.6	13.3	12.1	10.7			9.5	8.6			
30.0	19.2	18.2	17.3	16.7		16.5	15.4	14.2	13.2	12.4	12.9	11.8	10.4	9.5		9.3	8.3	7.0		
32.0	18.3	17.5	16.7	16.2		15.7	14.8	13.7	13.0	12.3	12.6	11.5	10.2	9.2	8.4	9.1	8.0	6.8		
34.0	15.9	16.5	16.1	15.7		15.1	14.2	13.2	12.6	12.2	12.2	11.2	9.9	9.0	8.3	8.8	7.7	6.6	5.9	
36.0	13.7	14.2	14.8	15.1		14.5	13.6	12.8	12.3	12.1	11.9	10.9	9.7	8.8	8.2	8.4	7.4	6.4	5.8	
38.0	11.5	12.1	12.7	12.9		13.9	13.2	12.4	11.9		11.6	10.6	9.5	8.6	8.1	8.2	7.2	6.3	5.7	5.3
40.0	9.4	10.0	10.5			12.4	12.7	12.0	11.6		11.3	10.3	9.3	8.5	8.0	7.9	7.0	6.1	5.6	5.2
42.0	7.6	8.1	8.5			10.7	11.6	11.6	11.3		10.9	10.1	9.1	8.3	8.0	7.6	6.8	5.9	5.4	5.1
44.0	5.9	6.3	6.7			9.0	9.8	10.8	11.1		10.4	9.8	8.9	8.2		7.4	6.6	5.8	5.3	5.1
46.0	4.4	4.8	5.0			7.4	8.2	9.1	9.4		9.7	9.6	8.7	8.1		7.1	6.4	5.7	5.2	5.0
48.0	3.1	3.3				6.0	6.7	7.4			8.3	9.3	8.5	8.0		6.9	6.2	5.5	5.1	5.0
50.0						4.8	5.4	5.9			7.0	8.0	8.4	7.9		6.7	6.1	5.4	5.1	5.0
54.0						2.5	2.9	3.2			4.7	5.5	6.4			6.3	5.8	5.2	4.9	
58.0											2.8	3.4	4.0			4.8	5.5	5.0	4.8	
62.0																3.1	3.9	4.8		
66.0																1.6	2.2	2.8		
θ(°)	34~84.5	34~84.5	39~84.5	53~84.5	67~84.5	35~84.5	37~84.5	38~84.5	53~84.5	67~84.5	37~84.5	41~84.5	44~84.5	57~84.5	68~84.5	36~84.5	40~84.5	43~84.5	56~84.5	68~84.5
標準フック	80t					25t					11.3t									
フック質量	1270kg					870kg					440kg									
標準巻掛本数	4					2					1									

注)カウンタウエイト 118t、アウトリガ張出幅 8.0m

■TFC性能 TRA+50. 6mブーム+1. 6m+フルオートラフィングジブ 単位:t

ジブ長さ(m)	10.3m					17.2m					24.1m					31.0m									
	オフセット					オフセット					オフセット					オフセット									
作業半径(m)	5°	15°	30°	45°	60°	5°	15°	30°	45°	60°	5°	15°	30°	45°	60°	5°	15°	30°	45°	60°					
10.0	21.0																								
11.0	20.9																								
12.0	20.9	19.2																							
14.0	20.3	17.9	15.5																						
16.0	19.0	16.9	14.7	13.3											12.2										
18.0	17.8	15.9	14.0	12.7	12.0										12.2					9.0					
20.0	16.7	15.0	13.3	12.2	11.6	13.8	12.1								11.7	10.1				9.0					
22.0	15.8	14.3	12.7	11.8	11.2	13.0	11.4	9.8	8.8						11.0	9.5				8.9					
24.0	14.9	13.6	12.2	11.3	10.9	12.3	10.8	9.4	8.5	7.9	10.4	9.0	7.7							8.9					
26.0	14.2	13.0	11.7	11.0	10.6	11.6	10.3	9.0	8.2	7.7	9.8	8.6	7.3							8.8					
28.0	13.5	12.4	11.3	10.6	10.3	11.0	9.8	8.6	7.9	7.4	9.3	8.2	7.0							8.3					
30.0	12.9	11.9	10.9	10.3	10.1	10.5	9.4	8.3	7.6	7.2	8.8	7.8	6.7	5.9						7.9					
32.0	12.3	11.4	10.5	10.0	9.8	10.0	9.0	8.0	7.4	7.0	8.4	7.5	6.5	5.7	5.1					7.5					
34.0	11.9	11.0	10.2	9.8		9.5	8.6	7.7	7.2	6.8	8.0	7.1	6.2	5.4	4.9	7.2	6.3	5.3							
36.0	11.4	10.6	9.9	9.5		9.1	8.3	7.5	6.9	6.6	7.6	6.8	5.9	5.2	4.8	6.8	6.0	5.1	4.4						
38.0	11.0	10.3	9.6	9.3		8.8	8.0	7.2	6.6	6.4	7.3	6.6	5.6	5.0	4.6	6.5	5.8	4.8	4.2						
40.0	9.9	10.0	9.4	9.1		8.4	7.7	7.0	6.4		7.0	6.2	5.3	4.8	4.4	6.2	5.5	4.6	4.0	3.6					
42.0	8.1	8.6	9.2	9.0		8.1	7.5	6.7	6.2		6.7	5.9	5.1	4.6	4.3	6.0	5.2	4.3	3.8	3.4					
44.0	6.5	6.9	7.4			7.8	7.2	6.5	6.1		6.4	5.6	4.9	4.4	4.2	5.6	4.9	4.1	3.6	3.3					
46.0	5.0	5.4	5.8			7.5	6.9	6.2	5.9		6.1	5.4	4.7	4.2		5.3	4.6	3.9	3.5	3.2					
48.0	3.6	4.0	4.3			6.3	6.6	6.0	5.8		5.8	5.1	4.5	4.1		5.0	4.4	3.7	3.3	3.1					
50.0	2.4	2.7	2.9			5.1	5.7	5.9			5.5	4.9	4.3	4.0		4.8	4.2	3.6	3.2	3.0					
54.0						2.8	3.4	3.9			4.9	4.5	4.0	3.7		4.3	3.8	3.2	2.9						
58.0											2.9	3.6	3.7			3.9	3.4	3.0	2.7						
62.0													2.4			3.2	3.1	2.7							
66.0																1.7	2.4	2.5							
70.0																		1.5							
θ(°)	37~84.5	38~84.5	39~84.5	52~84.5	66~84.5	41~84.5	43~84.5	45~84.5	54~84.5	67~84.5	44~84.5	46~84.5	44~84.5	56~84.5	68~84.5	42~84.5	45~84.5	43~84.5	60~84.5	70~84.5					
標準フック																25t					11.3t				
フック質量																870kg					440kg				
標準巻掛本数																2					1				

注)カウンタウエイト 118t、アウトリガ張出幅 8.0m

■TFC性能 TRA+55. 6mブーム+1. 6m+フルオートラフィングジブ 単位:t

ジブ長さ(m)	10.3m					17.2m					24.1m					31.0m									
	オフセット					オフセット					オフセット					オフセット									
作業半径(m)	5°	15°	30°	45°	60°	5°	15°	30°	45°	60°	5°	15°	30°	45°	60°	5°	15°	30°	45°	60°					
11.0	15.0																								
12.0	15.0																								
14.0	14.9	15.2																							
16.0	14.9	15.0	13.3																						
18.0	14.8	14.1	12.6	11.6	11.0																				
20.0	14.2	13.3	12.0	11.1	10.5	11.6	10.9	9.4																	
22.0	13.1	12.6	11.4	10.6	10.0	11.5	10.3	9.0																	
24.0	12.1	11.9	10.9	10.1	9.5	10.9	9.7	8.4	7.5																
26.0	11.1	11.0	10.4	9.6	9.1	10.3	9.2	7.9	7.1	6.5	8.8	8.1	6.8												
28.0	10.3	10.2	9.9	9.2	8.7	9.7	8.7	7.5	6.7	6.2	8.6	7.6	6.4												
30.0	9.5	9.4	9.4	8.7	8.4	9.0	8.2	7.1	6.4	5.9	8.0	7.2	6.0												
32.0	8.8	8.7	8.7	8.3	8.0	8.4	7.7	6.7	6.0	5.6	7.5	6.7	5.7	5.0											
34.0	8.2	8.1	8.1	8.0		7.8	7.2	6.3	5.7	5.4	6.9	6.3	5.4	4.7	4.3	6.3	5.4	4.5							
36.0	7.6	7.5	7.5	7.5		7.2	6.8	6.0	5.5	5.2	6.5	5.9	5.1	4.5	4.1	5.9	5.1	4.3							
38.0	7.0	7.0	6.9	7.0		6.7	6.4	5.7	5.2	5.0	6.0	5.6	4.8	4.3	3.9	5.5	4.8	4.0	3.5						
40.0	6.5	6.5	6.4	6.5		6.2	6.1	5.4	5.0	4.8	5.6	5.2	4.5	4.0	3.7	5.1	4.5	3.8	3.3						
42.0	6.1	6.0	6.0	6.0		5.8	5.7	5.1	4.8		5.2	4.9	4.3	3.8	3.6	4.8	4.2	3.5	3.1						
44.0	5.7	5.6	5.6	5.6		5.4	5.3	4.9	4.6		4.9	4.7	4.0	3.6	3.4	4.5	3.9	3.3	2.9	2.7					
46.0	5.3	5.2	5.2			5.0	5.0	4.7	4.4		4.5	4.4	3.8	3.5	3.3	4.2	3.7	3.1	2.8	2.5					
48.0	4.3	4.7	4.8			4.6	4.6	4.4	4.2		4.2	4.1	3.6	3.3		3.9	3.5	2.9	2.6	2.4					
50.0	3.0	3.4	3.7			4.3	4.3	4.3	4.0		3.9	3.9	3.4	3.1		3.7	3.2	2.8	2.5	2.3					
54.0						3.1	3.7	3.7			3.4	3.4	3.1	2.9		3.2	2.9	2.4	2.2						
58.0								2.1			2.9	2.9	2.8	2.6		2.8	2.5	2.2	1.9						
62.0											1.6	2.2	2.5			2.4	2.2	1.9	1.7						
66.0																1.7	2.0	1.7							
70.0																		1.5							
θ(°)	44~84.5	45~84.5	46~84.5	54~84.5	68~84.5	46~84.5	48~84.5	45~84.5	56~84.5	68~84.5	44~84.5	47~84.5	49~84.5	55~84.5	69~84.5	47~84.5	50~84.5	49~84.5	59~84.5	72~84.5					
標準フック																25t					11.3t				
フック質量																870kg					440kg				
標準巻掛本数																2					1				

注)カウンタウエイト 118t、アウトリガ張出幅 8.0m

■TFC性能 TRA+60. 0mブーム+1. 6m+フルオートラフィングジブ 単位:t

ジブ長さ(m)	10.3m					17.2m					24.1m					31.0m				
	オフセット					オフセット					オフセット					オフセット				
作業半径(m)	5°	15°	30°	45°	60°	5°	15°	30°	45°	60°	5°	15°	30°	45°	60°	5°	15°	30°	45°	60°
12.0	11.5																			
14.0	11.4	11.7																		
16.0	11.4	11.7	12.3																	
18.0	11.4	11.6	11.7	10.8																
20.0	11.4	11.6	11.1	10.3	9.6	8.6	8.9													
22.0	11.4	11.6	10.6	9.8	9.1	8.6	8.9	8.6												
24.0	10.6	10.6	10.1	9.2	8.7	8.6	8.8	8.1												
26.0	9.7	9.7	9.5	8.8	8.3	8.6	8.6	7.6	6.8											
28.0	8.9	8.9	8.9	8.3	7.9	7.9	8.0	7.2	6.4	5.9	6.8	7.0	5.9							
30.0	8.1	8.1	8.1	7.9	7.5	7.3	7.3	6.8	6.1	5.6	6.8	6.6	5.6							
32.0	7.4	7.4	7.4	7.5	7.2	6.7	6.7	6.4	5.8	5.4	6.5	6.2	5.2	4.6						
34.0	6.8	6.8	6.8	6.8	6.9	6.2	6.2	6.1	5.5	5.1	6.0	5.8	4.9	4.3						
36.0	6.2	6.2	6.2	6.2		5.6	5.7	5.7	5.2	4.9	5.5	5.4	4.6	4.1						
38.0	5.5	5.6	5.6	5.7		5.2	5.2	5.3	4.9	4.7	5.0	5.1	4.4	3.9	3.6	4.9	4.4	3.7		
40.0	4.3	4.9	5.1	5.2		4.7	4.8	4.9	4.7	4.5	4.6	4.7	4.1	3.7	3.4	4.5	4.1	3.4	3.0	
42.0	3.2	3.7	4.4	4.7		4.3	4.3	4.4	4.5	4.3	4.2	4.3	3.9	3.5	3.2	4.1	3.8	3.2	2.8	
44.0	2.1	2.6	3.2	3.4		3.9	4.0	4.0	4.1		3.9	3.9	3.6	3.3	3.1	3.8	3.6	3.0	2.6	
46.0			2.1	2.3		3.6	3.6	3.7	3.8		3.5	3.6	3.4	3.1	2.9	3.4	3.3	2.8	2.5	
48.0						2.6	3.3	3.3	3.4		3.2	3.3	3.2	2.9	2.8	3.1	3.1	2.6	2.3	2.1
50.0						1.7	2.5	3.0	3.1		2.9	3.0	3.0	2.8		2.9	2.9	2.5	2.2	2.0
54.0								1.5	1.9		1.9	2.4	2.							

■TFD性能
TRA+40. 4mブーム+1. 6m+フルオートラフィングジブ 単位:t

作業半径(m)	10.3m					17.2m					24.1m					31.0m							
	オフセット					オフセット					オフセット					オフセット							
θ(°)	5°	15°	30°	45°	60°	5°	15°	30°	45°	60°	5°	15°	30°	45°	60°	5°	15°	30°	45°	60°			
9.0	37.6																						
10.0	37.5	38.3				16.7																	
11.0	37.4	38.1				16.7																	
12.0	37.3	38.0				16.7									16.7								
14.0	37.2	37.8	30.0	25.5		16.7	16.7							16.4					10.9				
16.0	37.2	36.0	28.7	24.7	22.7	16.7	16.7							16.0					10.9				
18.0	37.1	33.9	27.5	24.0	22.3	16.7	16.7	16.7						15.6	14.2				10.9				
20.0	35.2	32.1	26.4	23.4	22.0	16.7	16.7	16.7	14.9					15.2	13.7				10.7				
22.0	32.3	30.5	25.5	22.8	21.8	16.7	16.7	16.7	14.4	13.1				14.8	13.3				10.5	9.8			
24.0	27.3	28.3	24.6	22.4	21.6	16.7	16.7	16.2	14.0	12.9				14.3	12.9				10.3	9.4			
26.0	23.1	24.0	23.9	21.9	21.4	16.7	16.7	15.6	13.7	12.7				13.8	12.5	11.1			10.1	9.0			
28.0	19.6	20.4	21.4	21.6		16.7	16.7	15.1	13.3	12.5				13.3	12.1	10.8	9.6		9.9	8.6	7.3		
30.0	16.6	17.3	18.2	18.6		16.7	16.7	14.6	13.0	12.4				12.9	11.8	10.5	9.3	8.5	9.5	8.3	7.1		
32.0	14.0	14.6	15.4	15.7		16.7	16.2	14.1	12.8	12.3				12.5	11.5	10.2	9.1	8.4	9.1	8.0	6.8		
34.0	11.3	12.1	12.9	13.2		14.5	15.5	13.7	12.5	12.2				11.2	9.9	8.9	8.2	8.7	8.7	7.7	6.6	6.0	
36.0	9.0	9.7	10.3	10.6		12.4	13.4	13.3	12.3					11.8	10.9	9.7	8.7	8.1	8.4	7.4	6.4	5.8	
38.0	7.0	7.5	8.1			10.4	11.4	12.5	12.2					11.3	10.5	9.4	8.5	8.1	8.1	7.2	6.2	5.7	5.2
40.0	5.2	5.6	6.0			8.5	9.5	10.6	11.2					10.7	10.3	9.2	8.3	8.0	7.8	6.9	6.1	5.6	5.1
42.0	3.5	3.9	4.2			6.8	7.7	8.7	9.1					9.3	9.9	8.9	8.2		7.5	6.7	5.9	5.4	5.1
44.0		2.3				5.3	6.1	6.9						7.8	9.0	8.7	8.1		7.2	6.5	5.8	5.3	5.0
46.0						3.9	4.6	5.3						6.4	7.5	8.5	8.0		7.0	6.3	5.6	5.2	5.0
48.0						2.7	3.3	3.8						5.1	6.1	7.3	7.9		6.8	6.1	5.5	5.1	5.0
50.0							2.0	2.3						4.0	4.9	5.9			6.2	6.0	5.4	5.1	
54.0														2.0	2.6	3.3			4.1	5.1	5.2	4.9	
58.0																			2.4	3.2	4.2		
62.0																					2.1		
θ(°)	36~84.5	34~84.5	39~84.5	51~84.5	67~84.5	36~84.5	36~84.5	39~84.5	53~84.5	66~84.5	37~84.5	41~84.5	44~84.5	55~84.5	67~84.5	41~84.5	45~84.5	43~84.5	57~84.5	67~84.5			
標準フック	80t					25t					11.3t												
フック質量	1270kg					870kg					440kg												
標準巻掛本数	4					2					1												

注)カウンタウエイト 98t、アウトリガ張出幅 8.5m
または、カウンタウエイト 98t、アウトリガ張出幅 8.0m

■TFD性能
TRA+45. 4mブーム+1. 6m+フルオートラフィングジブ 単位:t

作業半径(m)	10.3m					17.2m					24.1m					31.0m								
	オフセット					オフセット					オフセット					オフセット								
θ(°)	5°	15°	30°	45°	60°	5°	15°	30°	45°	60°	5°	15°	30°	45°	60°	5°	15°	30°	45°	60°				
9.0	28.2																							
10.0	28.1																							
11.0	28.0	28.6				16.7																		
12.0	27.9	28.5				16.7																		
14.0	27.8	27.7	25.2			16.7	16.7							15.5										
16.0	27.8	26.0	23.8	22.3	21.3	16.7	16.7							15.2						10.6				
18.0	26.2	24.5	22.5	21.2	20.3	16.7	16.7							14.9	14.0					10.4				
20.0	24.7	23.1	21.4	20.3	19.5	16.7	16.7	16.7						14.6	13.6					10.2				
22.0	23.3	21.9	20.4	19.4	18.8	16.7	16.7	16.7	14.6					14.3	13.2					10.0	9.6			
24.0	22.1	20.8	19.5	18.6	18.1	16.7	16.7	16.2	14.2	12.9				14.0	12.8					9.8	9.3			
26.0	21.0	19.9	18.7	17.9	17.5	16.7	16.7	15.5	13.8	12.7				13.7	12.4	11.0				9.7	8.9			
28.0	19.8	19.0	17.9	17.3	16.9	16.7	16.1	14.8	13.5	12.6				13.3	12.1	10.7				9.5	8.6			
30.0	16.8	17.5	17.3	16.7		16.5	15.4	14.2	13.2	12.4				12.9	11.8	10.4	9.5			9.3	8.3	7.0		
32.0	14.2	14.9	15.7	16.1		15.7	14.8	13.7	13.0	12.3				12.6	11.5	10.2	9.2	8.4		9.1	8.0	6.8		
34.0	11.6	12.4	13.3	13.6		14.5	14.2	13.2	12.6	12.2				12.2	11.2	9.9	9.0	8.3		8.8	7.7	6.6	5.9	
36.0	9.3	10.0	10.8	11.2		12.5	13.5	12.8	12.3	12.1				11.9	10.9	9.7	8.8	8.2		8.4	7.4	6.4	5.8	
38.0	7.3	7.9	8.6	8.8		10.4	11.5	12.4	11.9					11.6	10.6	9.5	8.6	8.1		8.2	7.2	6.3	5.7	5.3
40.0	5.5	6.0	6.6			8.6	9.6	10.8	11.5					10.8	10.3	9.3	8.5	8.0		7.9	7.0	6.1	5.6	5.2
42.0	3.8	4.3	4.8			6.9	7.8	9.0	9.6					9.2	10.1	9.1	8.3	8.0		7.6	6.8	5.9	5.4	5.1
44.0	2.4	2.8	3.1			5.4	6.2	7.2	7.7					7.7	8.9	8.9	8.2			7.4	6.6	5.8	5.3	5.1
46.0						4.0	4.8	5.6	6.0					6.3	7.4	8.7	8.1			7.1	6.4	5.7	5.2	5.0
48.0						2.8	3.5	4.2						5.0	6.1	7.4	8.0			6.9	6.2	5.5	5.1	5.0
50.0							2.2	2.8						3.9	4.9	6.0	6.7			6.0	6.1	5.4	5.1	5.0
54.0														1.9	2.7	3.6				3.9	5.0	5.2	4.9	
58.0																				2.2	3.1	4.3	4.8	
62.0																					2.3			
θ(°)	41~84.5	42~84.5	43~84.5	53~84.5	67~84.5	45~84.5	44~84.5	46~84.5	53~84.5	67~84.5	43~84.5	47~84.5	50~84.5	57~84.5	68~84.5	46~84.5	50~84.5	49~84.5	56~84.5	68~84.5				
標準フック	80t					25t					11.3t													
フック質量	1270kg					870kg					440kg													
標準巻掛本数	4					2					1													

注)カウンタウエイト 98t、アウトリガ張出幅 8.5m
または、カウンタウエイト 98t、アウトリガ張出幅 8.0m

■TFE性能
TRA+55. 6mブーム+1. 6m+フルオートラフィングジブ 単位:t

ジブ長さ(m)	10.3m					17.2m					24.1m					31.0m				
	オフセット					オフセット					オフセット					オフセット				
作業半径(m)	5°	15°	30°	45°	60°	5°	15°	30°	45°	60°	5°	15°	30°	45°	60°	5°	15°	30°	45°	60°
11.0	15.0																			
12.0	15.0																			
14.0	14.9	15.2																		
16.0	14.9	15.0	13.3																	
18.0	14.8	14.1	12.6	11.6	11.0															
20.0	14.2	13.3	12.0	11.1	10.5	11.6	10.9	9.4												
22.0	13.1	12.6	11.4	10.6	10.0	11.5	10.3	9.0												
24.0	12.1	11.9	10.9	10.1	9.5	10.9	9.7	8.4	7.5											
26.0	11.1	11.0	10.4	9.6	9.1	10.3	9.2	7.9	7.1	6.5	8.8	8.1	6.8							
28.0	10.3	10.2	9.9	9.2	8.7	9.7	8.7	7.5	6.7	6.2	8.6	7.6	6.4							
30.0	9.5	9.4	9.4	8.7	8.4	9.0	8.2	7.1	6.4	5.9	8.0	7.2	6.0							
32.0	8.8	8.7	8.7	8.3	8.0	8.4	7.7	6.7	6.0	5.6	7.5	6.7	5.7	5.0						
34.0	8.0	8.1	8.1	8.0		7.8	7.2	6.3	5.7	5.4	6.9	6.3	5.4	4.7	4.3					
36.0	6.0	6.8	7.5	7.5		7.2	6.8	6.0	5.5	5.2	6.5	5.9	5.1	4.5	4.1	5.9	5.1	4.3		
38.0	4.2	4.9	5.7	6.2		6.6	6.4	5.7	5.2	5.0	6.0	5.6	4.8	4.3	3.9	5.5	4.8	4.0	3.5	
40.0			4.0	4.4		5.0	6.1	5.4	5.0	4.8	5.6	5.2	4.5	4.0	3.7	5.1	4.5	3.8	3.3	
42.0							4.6	5.1	4.8		5.2	4.9	4.3	3.8	3.6	4.8	4.2	3.5	3.1	
44.0								4.4	4.6		4.5	4.7	4.0	3.6	3.4	4.5	3.9	3.3	2.9	2.7
46.0											3.3	4.4	3.8	3.5	3.3	4.2	3.7	3.1	2.8	2.5
48.0												3.4	3.6	3.3		3.9	3.5	2.9	2.6	2.4
50.0													3.4	3.1			3.2	2.8	2.5	2.3
54.0																	2.4	2.2		
θ(°)	58~84.5	59~84.5	58~84.5	59~84.5	68~84.5	61~84.5	61~84.5	61~84.5	62~84.5	68~84.5	60~84.5	61~84.5	62~84.5	64~84.5	69~84.5	63~84.5	64~84.5	65~84.5	67~84.5	72~84.5
標準フック	25t										11.3t									
フック質量	870kg										440kg									
標準巻掛本数	2										1									

注)カウンタウエイト 78t、アウトリガ張出幅 8.5m
 または、カウンタウエイト 78t、アウトリガ張出幅 8.0m

■TFE性能
TRA+60. 0mブーム+1. 6m+フルオートラフィングジブ 単位:t

ジブ長さ(m)	10.3m					17.2m					24.1m					31.0m				
	オフセット					オフセット					オフセット					オフセット				
作業半径(m)	5°	15°	30°	45°	60°	5°	15°	30°	45°	60°	5°	15°	30°	45°	60°	5°	15°	30°	45°	60°
12.0	11.5																			
14.0	11.4	11.7																		
16.0	11.4	11.7	12.3																	
18.0	11.4	11.6	11.7	10.8																
20.0	11.4	11.6	11.1	10.3	9.6	8.6	8.9													
22.0	11.4	11.6	10.6	9.8	9.1	8.6	8.9	8.6												
24.0	10.6	10.6	10.1	9.2	8.7	8.6	8.8	8.1												
26.0	9.7	9.7	9.5	8.8	8.3	8.6	8.6	7.6	6.8											
28.0	8.9	8.9	8.9	8.3	7.9	7.9	8.0	7.2	6.4	5.9	6.8	7.0	5.9							
30.0	8.1	8.1	8.1	7.9	7.5	7.3	7.3	6.8	6.1	5.6	6.8	6.6	5.6							
32.0	7.4	7.4	7.4	7.5	7.2	6.7	6.7	6.4	5.8	5.4	6.5	6.2	5.2	4.6						
34.0	6.8	6.8	6.8	6.8	6.9	6.2	6.2	6.1	5.5	5.1	6.0	5.8	4.9	4.3						
36.0	5.9	6.2	6.2	6.2		5.6	5.7	5.7	5.2	4.9	5.5	5.4	4.6	4.1						
38.0			5.6	5.7		5.2	5.2	5.3	4.9	4.7	5.0	5.1	4.4	3.9	3.6	4.9	4.4	3.7		
40.0						4.7	4.8	4.9	4.7	4.5	4.6	4.7	4.1	3.7	3.4	4.5	4.1	3.4	3.0	
42.0							4.3	4.4	4.5	4.3	4.2	4.3	3.9	3.5	3.2	4.1	3.8	3.2	2.8	
44.0								4.0	4.1		3.9	3.9	3.6	3.3	3.1	3.8	3.6	3.0	2.6	
46.0									3.8			3.6	3.4	3.1	2.9	3.4	3.3	2.8	2.5	
48.0													3.2	2.9	2.8		3.1	2.6	2.3	2.1
50.0														2.8			2.9	2.5	2.2	2.0
54.0																	2.2	2.2	1.9	1.8
θ(°)	63~84.5	64~84.5	63~84.5	64~84.5	68~84.5	63~84.5	63~84.5	64~84.5	63~84.5	67~84.5	64~84.5	64~84.5	66~84.5	66~84.5	69~84.5	66~84.5	66~84.5	66~84.5	69~84.5	70~84.5
標準フック	25t										11.3t									
フック質量	870kg										440kg									
標準巻掛本数	2										1									

注)カウンタウエイト 78t、アウトリガ張出幅 8.5m
 または、カウンタウエイト 78t、アウトリガ張出幅 8.0m

■TFE性能
TRA+40. 4mブーム+1. 6m+フルオートラフィングジブ 単位:t

ジブ長さ(m)	10.3m					17.2m					24.1m					31.0m				
	オフセット					オフセット					オフセット					オフセット				
作業半径(m)	5°	15°	30°	45°	60°	5°	15°	30°	45°	60°	5°	15°	30°	45°	60°	5°	15°	30°	45°	60°
9.0	37.6																			
10.0	37.5	38.3																		
11.0	37.4	38.1																		
12.0	37.3	38.0																		
14.0	37.2	37.8	30.0	25.5																
16.0	37.2	36.0	28.7	24.7	22.7	16.7	16.7													
18.0	30.1	31.7	27.5	24.0	22.3	16.7	16.7	16.7												
20.0	24.1	25.5	26.4	23.4	22.0	16.7	16.7	16.7	14.9											
22.0	19.4	20.6	22.1	22.8	21.8	16.7	16.7	16.7	14.4	13.1	14.8	13.3								
24.0	15.3	16.6	18.0	18.9	19.3	16.7	16.7	16.2	14.0	12.9	14.3	12.9	11.5							
26.0	11.6	12.8	14.4	15.2	15.5	15.3	16.7	15.6	13.7	12.7	13.8	12.5	11.1							
28.0	8.6	9.6	10.9	11.8		12.2	14.0	15.1	13.3	12.5	13.3	12.1	10.8	9.6						
30.0	6.0	6.9	8.0	8.7		9.5	11.1	13.2	13.0	12.4	12.1	11.8	10.5	9.3	8.5	9.9	8.6	7.3		
32.0		4.6	5.5	6.0		7.2	8.7	10.6	11.9	12.3	9.8	11.5	10.2	9.1	8.4	9.1	8.0	6.8		
34.0						5.2	6.5	8.2	9.4	9.9	7.7	9.6	9.9	8.9	8.2	8.7	7.7	6.6	6.0	
36.0						3.5	4.7	6.2	7.1		6.0	7.6	9.7	8.7	8.1	8.3	7.4	6.4	5.8	
38.0								4.3	5.1		4.4	5.9	8.0	8.5	8.1	6.7	7.2	6.2	5.7	
40.0												4.4	6.3	7.6	8.0	5.3	6.9	6.1	5.6	5.1
42.0													4.7	5.9		4.0	5.7	5.9	5.4	5.1
44.0														4.3		2.8	4.4	5.8	5.3	5.0
46.0																	3.2	5.1	5.2	5.0
48.0																		3.9	5.1	5.0
50.0																		2.7	3.9	
θ(°)	56~84.5	55~84.5	57~84.5	58~84.5	67~84.5	54~84.5	58~84.5	58~84.5	59~84.5	66~84.5	58~84.5	59~84.5	61~84.5	61~84.5	67~84.5	57~84.5	59~84.5	60~84.5	63~84.5	67~84.5
標準フック	80t										11.3t									
フック質量	1270kg										870kg									
標準巻掛本数	4										2									

注)カウンタウエイト 78t、アウトリガ張出幅 6.8m
 または、カウンタウエイト 58t、アウトリガ張出幅 8.5m
 または、カウンタウエイト 58t、アウトリガ張出幅 8.0m

■TFF性能 TRA+45. 4mブーム+1. 6m+フルオートラフingジブ 単位:t

ジブ長さ(m)	10.3m					17.2m					24.1m					31.0m				
	オフセット					オフセット					オフセット					オフセット				
作業半径(m)	5°	15°	30°	45°	60°	5°	15°	30°	45°	60°	5°	15°	30°	45°	60°	5°	15°	30°	45°	60°
9.0	28.2																			
10.0	28.1																			
11.0	28.0	28.6								16.7										
12.0	27.9	28.5								16.7										
14.0	27.8	27.7	25.2							16.7	16.7				15.5					
16.0	27.8	26.0	23.8	22.3	21.3					16.7	16.7				15.2				10.6	
18.0	26.2	24.5	22.5	21.2	20.3					16.7	16.7				14.9	14.0			10.4	
20.0	24.3	23.1	21.4	20.3	19.5					16.7	16.7				14.6	13.6			10.2	
22.0	19.6	20.8	20.4	19.4	18.8					16.7	16.7	14.6			14.3	13.2			10.0	9.6
24.0	15.5	16.8	18.2	18.6	18.1					16.7	16.7	16.2	14.2	12.9	14.0	12.8			9.8	9.3
26.0	11.8	13.1	14.7	15.5	15.9	15.3				16.7	16.7	15.5	13.8	12.7	13.7	12.4	11.0		9.7	8.9
28.0	8.8	9.9	11.3	12.2	12.5	12.2	14.0	14.8	13.5	12.6	13.3	13.3	12.1	10.7				9.5	8.6	
30.0	6.2	7.2	8.4	9.1		9.5	11.2	13.2	13.2	12.4	11.9	11.8	10.4	9.5				9.3	8.3	7.0
32.0			5.9	6.5		7.2	8.7	10.7	12.1	12.3	9.6	11.5	10.2	9.2	8.4	9.1	8.0	6.8		
34.0						5.2	6.6	8.4	9.7	10.3	7.6	9.5	9.9	9.0	8.3	8.8	7.7	6.6	5.9	
36.0							4.7	6.3	7.4	7.9	5.8	7.6	9.7	8.8	8.2	8.0	7.4	6.4	5.8	
38.0								4.5	5.5			5.8	8.0	8.6	8.1	6.4	7.2	6.3	5.7	5.3
40.0												4.3	6.3	7.8	8.0	5.0	6.9	6.1	5.6	5.2
42.0													4.7	6.1	6.7	3.8	5.5	5.9	5.4	5.1
44.0														4.5			4.2	5.8	5.3	5.1
46.0																		5.1	5.2	5.0
48.0																		3.9	5.1	5.0
50.0																			4.0	4.6
θ(°)	61~84.5	62~84.5	61~84.5	62~84.5	67~84.5	62~84.5	62~84.5	62~84.5	63~84.5	67~84.5	63~84.5	63~84.5	65~84.5	65~84.5	68~84.5	62~84.5	64~84.5	65~84.5	66~84.5	68~84.5
標準フック	80t					25t					11.3t									
フック質量	1270kg					870kg					440kg									
標準巻掛本数	4					2					1									

注)カウンタウエイト 78t、アウトリガ張出幅 6.8m
 または、カウンタウエイト 58t、アウトリガ張出幅 8.5m
 または、カウンタウエイト 58t、アウトリガ張出幅 8.0m

■TFF性能 TRA+50. 5mブーム+1. 6m+フルオートラフingジブ 単位:t

ジブ長さ(m)	10.3m					17.2m					24.1m					31.0m					
	オフセット					オフセット					オフセット					オフセット					
作業半径(m)	5°	15°	30°	45°	60°	5°	15°	30°	45°	60°	5°	15°	30°	45°	60°	5°	15°	30°	45°	60°	
10.0	21.0																				
11.0	20.9																				
12.0	20.9	19.2						15.9													
14.0	20.3	17.9	15.5					15.8													
16.0	19.0	16.9	14.7	13.3				15.8	13.5					12.2							
18.0	17.8	15.9	14.0	12.7	12.0			14.7	12.8					12.2							
20.0	16.7	15.0	13.3	12.2	11.6			13.8	12.1	10.3			11.7	10.1				9.0			
22.0	15.8	14.3	12.7	11.8	11.2			13.0	11.4	9.8	8.8			11.0	9.5			8.9			
24.0	14.9	13.6	12.2	11.3	10.9	12.3	10.8	9.4	8.5	7.9			10.4	9.0	7.7			8.9	8.0		
26.0	12.3	13.0	11.7	11.0	10.6	11.6	10.3	9.0	8.2	7.7	9.8	8.6	7.3				8.8	7.6			
28.0	9.2	10.4	11.3	10.6	10.3	11.0	9.8	8.6	7.9	7.4	9.3	8.2	7.0				8.3	7.3			
30.0	6.7	7.7	8.9	9.7	10.1	9.7	9.4	8.3	7.6	7.2	8.8	7.8	6.7	5.9			7.9	6.9	5.9		
32.0			6.4	7.1	7.3	7.4	9.0	8.0	7.4	7.0	8.4	7.5	6.5	5.7	5.1		7.5	6.6	5.6		
34.0						5.5	6.9	7.7	7.2	6.8	7.6	7.1	6.2	5.4	4.9		7.2	6.3	5.3		
36.0								6.7	6.9	6.6	5.9	6.8	5.9	5.2	4.8		6.8	6.0	5.1	4.4	
38.0									5.9	6.3			6.0	5.6	5.0	4.6	6.4	5.8	4.8	4.2	
40.0													5.3	4.8	4.4		5.0	5.5	4.6	4.0	3.6
42.0													4.9	4.6	4.3			5.2	4.3	3.8	3.4
44.0														4.4	4.2			4.2	4.1	3.6	3.3
46.0																			3.9	3.5	3.2
48.0																			3.7	3.3	3.1
50.0																				3.2	3.0
θ(°)	63~84.5	64~84.5	64~84.5	65~84.5	66~84.5	63~84.5	66~84.5	66~84.5	66~84.5	67~84.5	66~84.5	67~84.5	67~84.5	67~84.5	68~84.5	66~84.5	67~84.5	68~84.5	69~84.5	70~84.5	
標準フック	80t					25t					11.3t										
フック質量	1270kg					870kg					440kg										
標準巻掛本数	4					2					1										

注)カウンタウエイト 78t、アウトリガ張出幅 6.8m
 または、カウンタウエイト 58t、アウトリガ張出幅 8.5m
 または、カウンタウエイト 58t、アウトリガ張出幅 8.0m

■TFF性能 TRA+55. 6mブーム+1. 6m+フルオートラフingジブ 単位:t

ジブ長さ(m)	10.3m					17.2m					24.1m					31.0m					
	オフセット					オフセット					オフセット					オフセット					
作業半径(m)	5°	15°	30°	45°	60°	5°	15°	30°	45°	60°	5°	15°	30°	45°	60°	5°	15°	30°	45°	60°	
11.0	15.0																				
12.0	15.0																				
14.0	14.9	15.2						11.7													
16.0	14.9	15.0	13.3					11.6						8.8							
18.0	14.8	14.1	12.6	11.6	11.0			11.6	11.5					8.8					6.8		
20.0	14.2	13.3	12.0	11.1	10.5	11.6	10.9	9.4						8.8					6.7		
22.0	13.1	12.6	11.4	10.6	10.0	11.5	10.3	9.0						8.8	9.0				6.7		
24.0	12.1	11.9	10.9	10.1	9.5	10.9	9.7	8.4	7.5					8.8	8.5				6.7		
26.0	11.1	11.0	10.4	9.6	9.1	10.3	9.2	7.9	7.1	6.5	8.8	8.1	6.8					6.7	7.0		
28.0	10.0	10.2	9.9	9.2	8.7	9.7	8.7	7.5	6.7	6.2	8.6	7.6	6.4					6.7	6.7		
30.0	7.4	8.4	9.4	8.7	8.4	9.0	8.2	7.1	6.4	5.9	8.0	7.2	6.0					6.7	6.2		
32.0			7.2	8.0	8.0	7.6	7.7	6.7	6.0	5.6	7.5	6.7	5.7	5.0				6.7	5.8	4.8	
34.0							7.1	6.3	5.7	5.4	6.9	6.3	5.4	4.7	4.3			6.3	5.4	4.5	
36.0								6.0	5.5	5.2	6.3	5.9	5.1	4.5	4.1			5.9	5.1	4.3	
38.0									5.2	5.0			5.6	4.8	4.3	3.9		5.5	4.8	4.0	3.5
40.0												4.9	4.5	4.0	3.7			5.0	4.5	3.8	3.3
42.0													4.3	3.8	3.6				4.2	3.5	3.1
44.0														3.6	3.4				3.3	2.9	2.7
46.0															3.3				3.1	2.8	2.5
48.0																				2.6	2.4
50.0																				2.5	2.3
θ(°)	66~84.5	67~84.5	67~84.5	68~84.5	68~84.5	68~84.5	68~84.5	69~84.5	69~84.5	69~84.5	68~84.5	68~84.5	69~84.5	70~84.5	69~84.5	69~84.5	71~84.5	71~84.5	71~84.5	72~84.5	
標準フック	25t					870kg					11.3t										
フック質量	870kg					440kg															
標準巻掛本数	2					1															

注)カウンタウエイト 78t、アウトリガ張出幅 6.8m
 または、カウンタウエイト 58t、アウトリガ張出幅 8.5m
 または、カウンタウエイト 58t、アウトリガ張出幅 8.0m

■TFE性能

TRA+60. 0mブーム+1. 6m+フルオートラフingジブ

単位:t

ジブ長さ(m)	10.3m					17.2m					24.1m					31.0m				
	オフセット					オフセット					オフセット					オフセット				
	5°	15°	30°	45°	60°	5°	15°	30°	45°	60°	5°	15°	30°	45°	60°	5°	15°	30°	45°	
12.0	11.5																			
14.0	11.4	11.7				8.7														
16.0	11.4	11.7	12.3			8.7														
18.0	11.4	11.6	11.7	10.8		8.7	9.0				6.8									
20.0	11.4	11.6	11.1	10.3	9.6	8.6	8.9				6.8						5.3			
22.0	11.4	11.6	10.6	9.8	9.1	8.6	8.9	8.6			6.8	7.1				5.3				
24.0	10.6	10.6	10.1	9.2	8.7	8.6	8.8	8.1			6.8	7.0				5.3				
26.0	9.7	9.7	9.5	8.8	8.3	8.6	8.6	7.6	6.8		6.8	7.0				5.3	5.3			
28.0	8.9	8.9	8.9	8.3	7.9	7.9	8.0	7.2	6.4	5.9	6.8	7.0	5.9			5.3	5.3			
30.0		8.1	8.1	7.9	7.5	7.3	7.3	6.8	6.1	5.6	6.8	6.6	5.6			5.3	5.3			
32.0				7.5	7.2	6.7	6.7	6.4	5.8	5.4	6.5	6.2	5.2	4.6		5.3	5.3			
34.0							6.2	6.1	5.5	5.1	6.0	5.8	4.9	4.3		5.3	5.0	4.2		
36.0								5.7	5.2	4.9		5.4	4.6	4.1		5.3	4.7	3.9		
38.0									4.9	4.7		5.1	4.4	3.9	3.6	4.9	4.4	3.7		
40.0													4.1	3.7	3.4		4.1	3.4	3.0	
42.0															3.5	3.2		3.2	2.8	
44.0															3.3	3.1		3.0	2.6	
46.0																			2.5	
48.0																			2.3	
θ(°)	70~84.5	69~84.5	70~84.5	70~84.5	70~84.5	70~84.5	70~84.5	71~84.5	71~84.5	71~84.5	71~84.5	71~84.5	71~84.5	72~84.5	71~84.5	72~84.5	71~84.5	73~84.5	74~84.5	74~84.5
標準フック	25t					11.3t					11.3t									
フック質量	870kg					440kg					440kg									
標準巻掛本数	2					1					1									

注)カウンタウエイト 78t、アウトリガ張出幅 6.8m
 または、カウンタウエイト 58t、アウトリガ張出幅 8.5m
 または、カウンタウエイト 58t、アウトリガ張出幅 8.0m

■TFG性能

TRA+40. 4mブーム+1. 6m+フルオートラフingジブ

単位:t

ジブ長さ(m)	10.3m					17.2m					24.1m					31.0m					
	オフセット					オフセット					オフセット					オフセット					
	5°	15°	30°	45°	60°	5°	15°	30°	45°	60°	5°	15°	30°	45°	60°	5°	15°	30°	45°	60°	
9.0	37.6																				
10.0	37.5	38.3				16.7															
11.0	37.4	38.1				16.7															
12.0	37.3	38.0				16.7															
14.0	37.2	37.8	30.0	25.5		16.7	16.7				16.4						10.9				
16.0	31.7	33.7	28.7	24.7	22.7	16.7	16.7				16.0						10.9				
18.0	24.7	26.4	27.5	24.0	22.3	16.7	16.7	16.7			15.6	14.2					10.9				
20.0	19.3	20.7	22.6	23.4	22.0	16.7	16.7	16.7	14.9		15.2	13.7					10.7				
22.0	14.6	16.2	17.9	19.1	19.7	16.7	16.7	16.7	14.4	13.1	14.8	13.3					10.5	9.8			
24.0	10.8	12.1	13.9	15.1	15.5	14.5	16.4	16.2	14.0	12.9	14.3	12.9	11.5				10.3	9.4			
26.0	7.6	8.8	10.3	11.3	11.6	11.2	13.2	15.5	13.7	12.7	13.8	12.5	11.1				10.1	9.0			
28.0		6.0	7.3	8.1		8.5	10.3	12.6	13.3	12.5	11.0	12.1	10.8	9.6			9.9	8.6	7.3		
30.0						6.1	7.7	9.8	11.4	12.3	8.7	10.9	10.5	9.3	8.5		9.5	8.3	7.1		
32.0				5.3			5.6	7.4	8.8	9.5	6.6	8.6	10.2	9.1	8.4		9.0	8.0	6.8		
34.0								5.3	6.5	7.0	4.9	6.7	9.1	8.9	8.2		7.2	7.7	6.6	6.0	
36.0									4.4			4.9	7.2	8.7	8.1		5.6	7.4	6.4	5.8	
38.0													5.4	7.0	7.9		4.2	6.1	6.2	5.7	5.2
40.0														5.2	5.9			4.7	6.1	5.6	5.1
42.0																			5.6	5.4	5.1
44.0																			4.3	5.3	5.0
46.0																				4.6	5.0
48.0																				3.3	3.9
θ(°)	62~84.5	61~84.5	63~84.5	61~84.5	67~84.5	61~84.5	63~84.5	63~84.5	62~84.5	66~84.5	62~84.5	64~84.5	66~84.5	66~84.5	67~84.5	63~84.5	65~84.5	67~84.5	65~84.5	67~84.5	67~84.5
標準フック	90t					25t					25t					11.3t					
フック質量	1270kg					870kg					440kg					440kg					
標準巻掛本数	4					2					2					1					

注)カウンタウエイト 58t、アウトリガ張出幅 6.8m
 または、カウンタウエイト 47t、アウトリガ張出幅 8.5m
 または、カウンタウエイト 47t、アウトリガ張出幅 8.0m

■TFG性能

TRA+45. 4mブーム+1. 6m+フルオートラフingジブ

単位:t

ジブ長さ(m)	10.3m					17.2m					24.1m					31.0m					
	オフセット					オフセット					オフセット					オフセット					
	5°	15°	30°	45°	60°	5°	15°	30°	45°	60°	5°	15°	30°	45°	60°	5°	15°	30°	45°	60°	
9.0	28.2																				
10.0	28.1																				
11.0	28.0	28.6				16.7															
12.0	27.9	28.5				16.7															
14.0	27.8	27.7	25.2			16.7	16.7				15.5										
16.0	27.8	26.0	23.8	22.3	21.3	16.7	16.7				15.2						10.6				
18.0	24.9	24.5	22.5	21.2	20.3	16.7	16.7				14.9	14.0					10.4				
20.0	19.5	20.9	21.4	20.3	19.5	16.7	16.7				14.6	13.6					10.2				
22.0	14.8	16.4	18.2	19.4	18.8	16.7	16.7	16.7	14.6		14.3	13.2					10.0	9.6			
24.0	11.0	12.4	14.1	15.4	15.9	14.4	16.5	16.2	14.2	12.9	14.0	12.8					9.8	9.3			
26.0	7.8	9.0	10.6	11.7	12.1	11.2	13.2	15.5	13.8	12.7	13.6	12.4	11.0				9.7	8.9			
28.0			7.6	8.5	8.8	8.5	10.3	12.7	13.5	12.6	10.9	12.1	10.7				9.5	8.6			
30.0						6.1	7.8	10.0	11.6	12.4	8.5	10.7	10.4	9.5			9.3	8.3	7.0		
32.0							5.6	7.6	9.0	9.8	6.5	8.5	10.2	9.2	8.4		8.7	8.0	6.8		
34.0								5.5	6.8	7.4		6.6	9.1	9.0	8.3		6.9	7.7	6.6	5.9	
36.0													7.2	8.8	8.2		5.3	7.4	6.4	5.8	
38.0													5.4	7.1	8.1		5.9	6.3	5.7	5.3	
40.0														5.4	6.2		4.5	6.1	5.6	5.2	
42.0																		5.6	5.4	5.1	
44.0																		4.3	5.3	5.1	
46.0																			4.6	5.0	
48.0																				4.2	
θ(°)	65~84.5	66~84.5	66~84.5	67~84.5	67~84.5	66~84.5	66~84.5	67~84.5	68~84.5	67~84.5	67~84.5	69~84.5	69~84.5	69~84.5	70~84.5	67~84.5	68~84.5	69~84.5	71~84.5	70~84.5	
標準フック	90t					25t					25t					11.3t					
フック質量	1270kg					870kg					440kg					440kg					
標準巻掛本数	4					2					2					1					

注)カウンタウエイト 58t、アウトリガ張出幅 6.8m
 または、カウンタウエイト 47t、アウトリガ張出幅 8.5m
 または、カウンタウエイト 47t、アウトリガ張出幅 8.0m

■TFG性能 TRA+50. 6mブーム+1. 6m+フルオートラフィングジブ 単位:t

ジブ長さ(m)	10.3m					17.2m					24.1m					31.0m						
	オフセット					オフセット					オフセット					オフセット						
	5°	15°	30°	45°	60°	5°	15°	30°	45°	60°	5°	15°	30°	45°	60°	5°	15°	30°	45°	60°		
10.0	21.0																					
11.0	20.9																					
12.0	20.9	19.2				15.9																
14.0	20.3	17.9	15.5			15.8																
16.0	19.0	16.9	14.7	13.3		15.8	13.5				12.2											
18.0	17.8	15.9	14.0	12.7	12.0	14.7	12.8				12.2					9.0						
20.0	16.7	15.0	13.3	12.2	11.6	13.8	12.1	10.3			11.7	10.1				9.0						
22.0	15.3	14.3	12.7	11.8	11.2	13.0	11.4	9.8	8.8		11.0	9.5				8.9						
24.0	11.4	12.8	12.2	11.3	10.9	12.3	10.8	9.4	8.5	7.9	10.4	9.0	7.7			8.9	8.0					
26.0	8.3	9.5	11.1	11.0	10.6	11.4	10.3	9.0	8.2	7.7	9.8	8.6	7.3			8.8	7.6					
28.0																8.3	7.3					
30.0																7.9	6.9	5.9				
32.0																7.9	7.4	7.0	5.1			
34.0																7.9	7.4	7.0	5.1			
36.0																6.7	6.2	5.4	4.9			
38.0																5.9	5.2	4.8	5.3			
40.0																	5.0	4.6	5.8			
42.0																		4.8	4.4			
44.0																			4.6	4.0	3.6	
46.0																				4.3	3.8	3.4
48.0																					3.6	3.3
θ(°)	67~84.5	69~84.5	68~84.5	69~84.5	70~84.5	69~84.5	69~84.5	70~84.5	70~84.5	69~84.5	69~84.5	70~84.5	72~84.5	71~84.5	73~84.5	69~84.5	71~84.5	73~84.5	73~84.5	72~84.5		
標準フック	25t															11.3t						
フック質量	870kg															440kg						
標準巻掛本数	2															1						

注)カウンタウエイト 58t、アウトリガ張出幅 6.8m
 または、カウンタウエイト 47t、アウトリガ張出幅 8.5m
 または、カウンタウエイト 47t、アウトリガ張出幅 8.0m

■TFG性能 TRA+55. 6mブーム+1. 6m+フルオートラフィングジブ 単位:t

ジブ長さ(m)	10.3m					17.2m					24.1m					31.0m				
	オフセット					オフセット					オフセット					オフセット				
	5°	15°	30°	45°	60°	5°	15°	30°	45°	60°	5°	15°	30°	45°	60°	5°	15°	30°	45°	
11.0	15.0																			
12.0	15.0																			
14.0	14.9	15.2				11.7														
16.0	14.9	15.0	13.3			11.6					8.8									
18.0	14.8	14.1	12.6	11.6	11.0	11.6	11.5				8.8					6.8				
20.0	14.2	13.3	12.0	11.1	10.5	11.6	10.9	9.4			8.8					6.7				
22.0	13.1	12.6	11.4	10.6	10.0	11.5	10.3	9.0			8.8	9.0				6.7				
24.0	12.1	11.9	10.9	10.1	9.5	10.9	9.7	8.4	7.5		8.8	8.5				6.7				
26.0	9.0	10.2	10.4	9.6	9.1	10.3	9.2	7.9	7.1	6.5	8.8	8.1	6.8			6.7	7.0			
28.0			8.8	9.2	8.7	8.9	8.7	7.5	6.7	6.2	8.6	7.6	6.4			6.7	6.7			
30.0																6.7	6.2			
32.0																6.7	6.2			
34.0																6.7	5.8	4.8		
36.0																6.3	5.4	4.5		
38.0																	5.1	4.5	4.1	
40.0																	4.8	4.3	3.9	
42.0																		4.0	3.7	
44.0																			3.6	
θ(°)	70~84.5	71~84.5	71~84.5	72~84.5	70~84.5	71~84.5	71~84.5	73~84.5	73~84.5	73~84.5	71~84.5	72~84.5	73~84.5	74~84.5	73~84.5	73~84.5	73~84.5	75~84.5	76~84.5	
標準フック	25t															11.3t				
フック質量	870kg															440kg				
標準巻掛本数	2															1				

注)カウンタウエイト 58t、アウトリガ張出幅 6.8m
 または、カウンタウエイト 47t、アウトリガ張出幅 8.5m
 または、カウンタウエイト 47t、アウトリガ張出幅 8.0m

■TFG性能 TRA+60. 0mブーム+1. 6m+フルオートラフィングジブ 単位:t

ジブ長さ(m)	10.3m					17.2m					24.1m					31.0m				
	オフセット					オフセット					オフセット					オフセット				
	5°	15°	30°	45°	60°	5°	15°	30°	45°	60°	5°	15°	30°	45°		5°	15°	30°	45°	
12.0	11.5																			
14.0	11.4	11.7				8.7														
16.0	11.4	11.7	12.3			8.7														
18.0	11.4	11.6	11.7	10.8		8.7	9.0				6.8									
20.0	11.4	11.6	11.1	10.3	9.6	8.6	8.9				6.8					5.3				
22.0	11.4	11.6	10.6	9.8	9.1	8.6	8.9	8.6			6.8	7.1				5.3				
24.0	10.6	10.6	10.1	9.2	8.7	8.6	8.8	8.1			6.8	7.0				5.3				
26.0		9.7	9.5	8.8	8.3	8.6	8.6	7.6	6.8		6.8	7.0				5.3	5.3			
28.0			8.8	8.3	7.9	7.9	8.0	7.2	6.4	5.9	6.8	7.0	5.9			5.3	5.3			
30.0																				
32.0																				
34.0																				
36.0																				
38.0																				
40.0																				
42.0																				
44.0																				
θ(°)	73~84.5	73~84.5	72~84.5	73~84.5	74~84.5	73~84.5	73~84.5	74~84.5	74~84.5	73~84.5	74~84.5	75~84.5	75~84.5	76~84.5	75~84.5	76~84.5	77~84.5	77~84.5		
標準フック	25t															11.3t				
フック質量	870kg															440kg				
標準巻掛本数	2															1				

注)カウンタウエイト 58t、アウトリガ張出幅 6.8m
 または、カウンタウエイト 47t、アウトリガ張出幅 8.5m
 または、カウンタウエイト 47t、アウトリガ張出幅 8.0m

8. TRA+ICA+フルオートラフィングジブ定格総荷重表

1. 定格総荷重表の性能区分 I F D ~ I F G は、下表のとおりです。

カウンタウエイト アウトリガ 張出幅	118 t	98 t	78 t	58 t	47 t
8.5m	I F D	I F D	I F E	I F F	I F G
8.0m	I F D	I F D	I F E	I F F	I F G
6.8m			I F F	I F G	

2. 定格総荷重は、つり具質量とフック質量（25 トフック：870 kg、11.3 トフック：440 kg）を含んだ値を示します。ESPブームのフックは取外してください。
3. 定格総荷重は、ブームのたわみを含んだ実際の作業半径に基づいています。
4. 各ブーム長さにおける各ブーム段の伸長状態（伸長割合%）は、下表のとおりです。

ブーム長さ	50.5m	55.6m	60.0m
伸縮ブーム1	90	90	100
伸縮ブーム2	90	90	100
伸縮ブーム3	90	90	100
伸縮ブーム4	45	90	100

5. ブーム長さ 50.5m未満での性能設定はありません。また、Bピン（ブーム固定ピン）を挿入していない状態では使用できません。
6. 定格総荷重表中の標準巻掛本数より少ない本数で使用する場合、最大荷重の上限は下表のとおりです。

掛数	2本	1本
最大荷重	22.5 t	11.3 t

7. 定格総荷重は、アウトリガを水平堅土上に設置したときの値です。
8. 定格総荷重表は、風による影響を含んでいません。瞬間最大風速が 10m/s 以上の風速では、クレーン作業を中止してください。
9. 定格総荷重表中の太線より上側はクレーンの強度に、下側はクレーンの安定に基づいています。
10. 「 θ (°)」は、無負荷状態で作動可能なブーム起伏角度範囲を示します。
11. 「オフセット」は下図のようにブームの中心線とジブの中心線とのなす角度を示します。

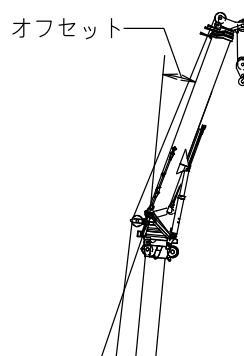

■IFD性能

TRA+ICA+50. 5mブーム+1. 6mフルオートラフィングジブ 単位:t

ジブ長さ(m)	10.3m		17.2m		24.1m		31.0m	
	オフセット		オフセット		オフセット		オフセット	
	5°	15°	5°	15°	5°	15°	5°	15°
10.0	25.0							
11.0	24.1							
12.0	23.1	20.2	16.7					
14.0	21.6	18.9	16.7					
16.0	20.2	17.9	16.7	14.2	14.1			
18.0	19.0	16.9	15.6	13.5	13.2		10.1	
20.0	17.9	16.1	14.7	12.8	12.4	10.6	10.0	
22.0	15.6	14.8	13.9	12.1	11.7	10.0	9.8	
24.0	13.7	12.9	13.1	11.5	11.0	9.5	9.6	8.4
26.0	11.9	11.4	11.8	11.0	10.5	9.1	9.3	8.0
28.0	10.5	10.0	10.4	9.9	9.9	8.6	8.9	7.6
30.0	9.1	8.7	9.2	8.8	9.2	8.1	8.4	7.1
32.0	8.0	7.6	8.1	7.8	8.2	7.7	8.0	6.7
34.0	6.9	6.6	7.2	6.9	7.3	7.0	7.6	6.4
36.0	6.0	5.7	6.3	6.0	6.5	6.3	6.8	6.0
38.0	5.1	4.8	5.5	5.3	5.7	5.6	6.1	5.7
40.0	4.3	4.1	4.8	4.6	5.0	4.9	5.4	5.3
42.0	3.6	3.4	4.1	3.9	4.4	4.3	4.8	4.8
44.0	2.9	2.7	3.5	3.3	3.8	3.8	4.3	4.2
46.0	2.3		2.9	2.8	3.3	3.3	3.8	3.7
48.0			2.4	2.3	2.8	2.8	3.3	3.3
50.0			1.9		2.4	2.3	2.8	2.8
54.0							2.0	2.0
θ(°)	43~84.5	48~84.5	46~84.5	51~84.5	52~84.5	55~84.5	54~84.5	58~84.5
標準フック	25t		25t		25t		11.3t	
フック質量	870kg		870kg		870kg		440kg	
標準巻掛本数	3		2		2		1	

注)カウンタウエイト 118t、アウトリガ張出幅 8.5m
 または、カウンタウエイト 118t、アウトリガ張出幅 8.0m
 または、カウンタウエイト 98t、アウトリガ張出幅 8.5m
 または、カウンタウエイト 98t、アウトリガ張出幅 8.0m

■IFD性能

TRA+ICA+60. 0mブーム+1. 6mフルオートラフィングジブ 単位:t

ジブ長さ(m)	10.3m		17.2m		24.1m		31.0m	
	オフセット		オフセット		オフセット		オフセット	
	5°	15°	5°	15°	5°	15°	5°	15°
12.0	17.0							
14.0	17.0	15.6	11.0					
16.0	16.3	14.6	11.0					
18.0	15.3	13.6	11.0	11.0	9.5			
20.0	14.4	12.8	11.0	10.7	9.5		8.0	
22.0	13.4	12.1	11.0	10.0	9.5	8.4	8.0	
24.0	11.6	10.9	10.9	9.4	9.3	7.9	8.0	
26.0	10.0	9.5	10.2	8.8	8.7	7.4	7.7	6.4
28.0	8.6	8.2	9.0	8.3	8.1	6.9	7.2	6.0
30.0	7.4	7.0	7.8	7.5	7.6	6.5	6.7	5.6
32.0	6.3	6.0	6.8	6.5	6.9	6.1	6.2	5.3
34.0	5.3	5.1	5.8	5.6	6.0	5.8	5.8	4.9
36.0	4.4	4.2	5.0	4.8	5.3	5.1	5.5	4.6
38.0	3.6	3.4	4.2	4.1	4.5	4.5	4.8	4.4
40.0	2.9	2.7	3.5	3.4	3.9	3.8	4.2	4.1
42.0	2.2	2.1	2.9	2.8	3.3	3.3	3.6	3.6
44.0			2.3	2.2	2.7	2.7	3.1	3.1
46.0			1.8	1.7	2.2	2.2	2.6	2.7
48.0					1.8	1.8	2.1	2.2
50.0							1.7	1.8
θ(°)	56~84.5	58~84.5	58~84.5	60~84.5	60~84.5	63~84.5	63~84.5	66~84.5
標準フック	25t		25t		11.3t		11.3t	
フック質量	870kg		870kg		440kg		440kg	
標準巻掛本数	2		1		1		1	

注)カウンタウエイト 118t、アウトリガ張出幅 8.5m
 または、カウンタウエイト 118t、アウトリガ張出幅 8.0m
 または、カウンタウエイト 98t、アウトリガ張出幅 8.5m
 または、カウンタウエイト 98t、アウトリガ張出幅 8.0m

■IFD性能

TRA+ICA+55. 6mブーム+1. 6mフルオートラフィングジブ 単位:t

ジブ長さ(m)	10.3m		17.2m		24.1m		31.0m	
	オフセット		オフセット		オフセット		オフセット	
	5°	15°	5°	15°	5°	15°	5°	15°
11.0	18.5							
12.0	18.5							
14.0	18.5	16.9	15.9					
16.0	17.7	15.9	14.8			11.3		
18.0	16.6	15.0	13.9	11.9	11.3		9.0	
20.0	15.7	14.0	13.0	11.1	11.3		9.0	
22.0	14.4	13.2	12.1	10.4	10.8	9.1	9.0	
24.0	12.5	11.8	11.3	9.8	10.1	8.5	8.9	
26.0	10.9	10.3	10.6	9.2	9.4	8.0	8.2	6.9
28.0	9.4	9.0	9.3	8.7	8.8	7.5	7.7	6.5
30.0	8.2	7.8	8.2	7.8	8.2	7.1	7.2	6.1
32.0	7.1	6.7	7.2	6.9	7.5	6.6	6.7	5.7
34.0	6.0	5.8	6.3	6.0	6.6	6.3	6.3	5.3
36.0	5.1	4.9	5.4	5.2	5.9	5.7	5.9	5.0
38.0	4.3	4.1	4.7	4.5	5.1	5.0	5.3	4.7
40.0	3.6	3.4	4.0	3.9	4.5	4.4	4.7	4.5
42.0	2.9	2.7	3.4	3.3	3.9	3.8	4.1	4.1
44.0	2.3	2.1	2.8	2.7	3.3	3.2	3.6	3.6
46.0			2.3	2.2	2.8	2.7	3.1	3.1
48.0					2.3	2.3	2.6	2.7
50.0					1.8	1.8	2.2	2.3
54.0								1.5
θ(°)	51~84.5	52~84.5	55~84.5	57~84.5	56~84.5	59~84.5	61~84.5	61~84.5
標準フック	25t		25t		11.3t		11.3t	
フック質量	870kg		870kg		440kg		440kg	
標準巻掛本数	2		2		1		1	

注)カウンタウエイト 118t、アウトリガ張出幅 8.5m
 または、カウンタウエイト 118t、アウトリガ張出幅 8.0m
 または、カウンタウエイト 98t、アウトリガ張出幅 8.5m
 または、カウンタウエイト 98t、アウトリガ張出幅 8.0m

■IFE性能

TRA+ICA+50. 5mブーム+1. 6mフルオートラフィングジブ 単位:t

ジブ長さ(m)	10.3m		17.2m		24.1m		31.0m	
	オフセット		オフセット		オフセット		オフセット	
	5°	15°	5°	15°	5°	15°	5°	15°
10.0	25.0							
11.0	24.1							
12.0	23.1	20.2	16.7					
14.0	21.6	18.9	16.7					
16.0	20.2	17.9	16.7	14.2	14.1			
18.0	19.0	16.9	15.6	13.5	13.2		10.1	
20.0	17.9	16.1	14.7	12.8	12.4	10.6	10.0	
22.0	15.6	14.8	13.9	12.1	11.7	10.0	9.8	
24.0	13.7	12.9	13.1	11.5	11.0	9.5	9.6	8.4
26.0	11.9	11.4	11.8	11.0	10.5	9.1	9.3	8.0
28.0	10.5	10.0	10.4	9.9	9.9	8.6	8.9	7.6
30.0	9.1	8.7	9.2	8.8	9.2	8.1	8.4	7.1
32.0	8.0	7.6	8.1	7.8	8.2	7.7	8.0	6.7
34.0	6.9	6.6	7.2	6.9	7.3	7.0	7.6	6.4
36.0	6.0	5.7	6.3	6.0	6.5	6.3	6.8	6.0
38.0	5.1	4.8	5.5	5.3	5.7	5.6	6.1	5.7
40.0	4.1	4.1	4.8	4.6	5.0	4.9	5.4	5.3
42.0		3.2	4.1	3.9	4.4	4.3	4.8	4.8
44.0			3.5	3.3	3.8	3.8	4.3	4.2
46.0			2.8	2.8	3.3	3.3	3.8	3.7
48.0				2.3	2.8	2.8	3.3	3.3
50.0					2.4	2.3	2.8	2.8
54.0							2.0	2.0
θ(°)	51~84.5	50~84.5	51~84.5	51~84.5	52~84.5	55~84.5	54~84.5	58~84.5
標準フック	25t		25t		11.3t		11.3t	
フック質量	870kg		870kg		440kg		440kg	
標準巻掛本数	3		2		1		1	

注)カウンタウエイト 78t、アウトリガ張出幅 8.5m
 または、カウンタウエイト 78t、アウトリガ張出幅 8.0m

■IFE性能

TRA+ICA+55. 6mブーム+1. 6m+フルオートラフィングジブ 単位:t

ジブ長さ(m)	10.3m		17.2m		24.1m		31.0m	
	オフセット		オフセット		オフセット		オフセット	
	5°	15°	5°	15°	5°	15°	5°	15°
11.0	18.5							
12.0	18.5							
14.0	18.5	16.9	15.9					
16.0	17.7	15.9	14.8		11.3			
18.0	16.6	15.0	13.9	11.9	11.3		9.0	
20.0	15.7	14.0	13.0	11.1	11.3		9.0	
22.0	14.4	13.2	12.1	10.4	10.8	9.1	9.0	
24.0	12.5	11.8	11.3	9.8	10.1	8.5	8.9	
26.0	10.9	10.3	10.6	9.2	9.4	8.0	8.2	6.9
28.0	9.4	9.0	9.3	8.7	8.8	7.5	7.7	6.5
30.0	8.2	7.8	8.2	7.8	8.2	7.1	7.2	6.1
32.0	7.1	6.7	7.2	6.9	7.5	6.6	6.7	5.7
34.0	6.0	5.8	6.3	6.0	6.6	6.3	6.3	5.3
36.0	5.1	4.9	5.4	5.2	5.9	5.7	5.9	5.0
38.0	4.3	4.1	4.7	4.5	5.1	5.0	5.3	4.7
40.0	3.6	3.4	4.0	3.9	4.5	4.4	4.7	4.5
42.0	2.9	2.7	3.4	3.3	3.9	3.8	4.1	4.1
44.0			2.8	2.7	3.3	3.2	3.6	3.6
46.0			2.3	2.2	2.8	2.7	3.1	3.1
48.0					2.3	2.3	2.6	2.7
50.0					1.8	1.8	2.2	2.3
54.0								1.5
θ(°)	53~84.5	54~84.5	55~84.5	57~84.5	56~84.5	59~84.5	61~84.5	61~84.5
標準フック	25t				11.3t			
フック質量	870kg				440kg			
標準巻掛本数	2				1			

注)カウンタウエイト 78t、アウトリガ張出幅 8.5m
または、カウンタウエイト 78t、アウトリガ張出幅 8.0m

■IFE性能

TRA+ICA+60. 0mブーム+1. 6m+フルオートラフィングジブ 単位:t

ジブ長さ(m)	10.3m		17.2m		24.1m		31.0m	
	オフセット		オフセット		オフセット		オフセット	
	5°	15°	5°	15°	5°	15°	5°	15°
12.0	17.0							
14.0	17.0	15.6	11.0					
16.0	16.3	14.6	11.0					
18.0	15.3	13.6	11.0	11.0	9.5			
20.0	14.4	12.8	11.0	10.7	9.5		8.0	
22.0	13.4	12.1	11.0	10.0	9.5	8.4	8.0	
24.0	11.6	10.9	10.9	9.4	9.3	7.9	8.0	
26.0	10.0	9.5	10.2	8.8	8.7	7.4	7.7	6.4
28.0	8.6	8.2	9.0	8.3	8.1	6.9	7.2	6.0
30.0	7.4	7.0	7.8	7.5	7.6	6.5	6.7	5.6
32.0	6.3	6.0	6.8	6.5	6.9	6.1	6.2	5.3
34.0	5.3	5.1	5.8	5.6	6.0	5.8	5.8	4.9
36.0	4.4	4.2	5.0	4.8	5.3	5.1	5.5	4.6
38.0	3.6	3.4	4.2	4.1	4.5	4.5	4.8	4.4
40.0	2.9	2.7	3.5	3.4	3.9	3.8	4.2	4.1
42.0		2.1	2.9	2.8	3.3	3.3	3.6	3.6
44.0			2.3	2.2	2.7	2.7	3.1	3.1
46.0			1.8	1.7	2.2	2.2	2.6	2.7
48.0					1.8	1.8	2.1	2.2
50.0							1.7	1.8
θ(°)	58~84.5	58~84.5	58~84.5	60~84.5	60~84.5	63~84.5	63~84.5	66~84.5
標準フック	25t				11.3t			
フック質量	870kg				440kg			
標準巻掛本数	2				1			

注)カウンタウエイト 78t、アウトリガ張出幅 8.5m
または、カウンタウエイト 78t、アウトリガ張出幅 8.0m

■IFF性能

TRA+ICA+50. 5mブーム+1. 6m+フルオートラフィングジブ 単位:t

ジブ長さ(m)	10.3m		17.2m		24.1m		31.0m	
	オフセット		オフセット		オフセット		オフセット	
	5°	15°	5°	15°	5°	15°	5°	15°
10.0	25.0							
11.0	24.1							
12.0	23.1	20.2	16.7					
14.0	21.6	18.9	16.7					
16.0	20.2	17.9	16.7	14.2	14.1			
18.0	19.0	16.9	15.6	13.5	13.2		10.1	
20.0	17.9	16.1	14.7	12.8	12.4	10.6	10.0	
22.0	15.6	14.8	13.9	12.1	11.7	10.0	9.8	
24.0	13.7	12.9	13.1	11.5	11.0	9.5	9.6	8.4
26.0	11.9	11.4	11.8	11.0	10.5	9.1	9.3	8.0
28.0	10.5	10.0	10.4	9.9	9.9	8.6	8.9	7.6
30.0	8.8	8.7	9.2	8.8	9.2	8.1	8.4	7.1
32.0	6.5	7.4	8.1	7.8	8.2	7.7	8.0	6.7
34.0		5.4	7.2	6.9	7.3	7.0	7.6	6.4
36.0			5.6	6.0	6.5	6.3	6.8	6.0
38.0			4.1	5.1	5.7	5.6	6.1	5.7
40.0					4.6	4.9	5.4	5.3
42.0						4.3	4.8	4.8
44.0							4.1	4.2
46.0								3.7
48.0								3.3
θ(°)	61~84.5	60~84.5	59~84.5	62~84.5	62~84.5	63~84.5	63~84.5	63~84.5
標準フック	25t				11.3t			
フック質量	870kg				440kg			
標準巻掛本数	3				2			

注)カウンタウエイト 78t、アウトリガ張出幅 6.8m
または、カウンタウエイト 58t、アウトリガ張出幅 8.5m
または、カウンタウエイト 58t、アウトリガ張出幅 8.0m

■IFF性能

TRA+ICA+55. 6mブーム+1. 6m+フルオートラフィングジブ 単位:t

ジブ長さ(m)	10.3m		17.2m		24.1m		31.0m	
	オフセット		オフセット		オフセット		オフセット	
	5°	15°	5°	15°	5°	15°	5°	15°
11.0	18.5							
12.0	18.5							
14.0	18.5	16.9	15.9					
16.0	17.7	15.9	14.8			11.3		
18.0	16.6	15.0	13.9	11.9	11.3		9.0	
20.0	15.7	14.0	13.0	11.1	11.3		9.0	
22.0	14.4	13.2	12.1	10.4	10.8	9.1	9.0	
24.0	12.5	11.8	11.3	9.8	10.1	8.5	8.9	
26.0	10.9	10.3	10.6	9.2	9.4	8.0	8.2	6.9
28.0	9.4	9.0	9.3	8.7	8.8	7.5	7.7	6.5
30.0	8.2	7.8	8.2	7.8	8.2	7.1	7.2	6.1
32.0	7.1	6.7	7.2	6.9	7.5	6.6	6.7	5.7
34.0	5.4	5.8	6.3	6.0	6.6	6.3	6.3	5.3
36.0			5.4	5.2	5.9	5.7	5.9	5.0
38.0				4.5	5.1	5.0	5.3	4.7
40.0					4.5	4.4	4.7	4.5
42.0					3.8	3.8	4.1	4.1
44.0						3.2	3.6	3.6
46.0								3.1
48.0								2.7
θ(°)	62~84.5	63~84.5	64~84.5	64~84.5	63~84.5	64~84.5	65~84.5	65~84.5
標準フック	25t				11.3t			
フック質量	870kg				440kg			
標準巻掛本数	2				1			

注)カウンタウエイト 78t、アウトリガ張出幅 6.8m
または、カウンタウエイト 58t、アウトリガ張出幅 8.5m
または、カウンタウエイト 58t、アウトリガ張出幅 8.0m

■IFG性能

TRA+ICA+60. 0mブーム+1. 6mフルオートラフィングジブ 単位:t

ジブ長さ(m)	10.3m		17.2m		24.1m		31.0m	
	オフセット		オフセット		オフセット		オフセット	
	5°	15°	5°	15°	5°	15°	5°	15°
12.0	17.0							
14.0	17.0	15.6	11.0					
16.0	16.3	14.6	11.0					
18.0	15.3	13.6	11.0	11.0	9.5			
20.0	14.4	12.8	11.0	10.7	9.5		8.0	
22.0	13.4	12.1	11.0	10.0	9.5	8.4	8.0	
24.0	11.6	10.9	10.9	9.4	9.3	7.9	8.0	
26.0	10.0	9.5	10.2	8.8	8.7	7.4	7.7	6.4
28.0	8.6	8.2	9.0	8.3	8.1	6.9	7.2	6.0
30.0	7.4	7.0	7.8	7.5	7.6	6.5	6.7	5.6
32.0	6.3	6.0	6.8	6.5	6.9	6.1	6.2	5.3
34.0		5.1	5.8	5.6	6.0	5.8	5.8	4.9
36.0			5.0	4.8	5.3	5.1	5.5	4.6
38.0				4.1	4.5	4.5	4.8	4.4
40.0					3.9	3.8	4.2	4.1
42.0						3.3	3.6	3.6
44.0								3.1
46.0								2.7
θ(°)	66~84.5	65~84.5	67~84.5	67~84.5	67~84.5	68~84.5	68~84.5	69~84.5
標準フック	25t				11.3t			
フック質量	870kg				440kg			
標準巻掛本数	2				1			

注)カウンタウエイト 78t、アウトリガ張出幅 6.8m
 または、カウンタウエイト 58t、アウトリガ張出幅 8.5m
 または、カウンタウエイト 58t、アウトリガ張出幅 8.0m

■IFG性能

TRA+ICA+50. 5mブーム+1. 6mフルオートラフィングジブ 単位:t

ジブ長さ(m)	10.3m		17.2m		24.1m		31.0m	
	オフセット		オフセット		オフセット		オフセット	
	5°	15°	5°	15°	5°	15°	5°	15°
10.0	25.0							
11.0	24.1							
12.0	23.1	20.2	16.7					
14.0	21.6	18.9	16.7					
16.0	20.2	17.9	16.7	14.2	14.1			
18.0	19.0	16.9	15.6	13.5	13.2		10.1	
20.0	17.9	16.1	14.7	12.8	12.4	10.6	10.0	
22.0	15.6	14.8	13.9	12.1	11.7	10.0	9.8	
24.0	13.5	12.9	13.1	11.5	11.0	9.5	9.6	8.4
26.0	10.4	11.4	11.8	11.0	10.5	9.1	9.3	8.0
28.0	7.7	8.7	10.4	9.9	9.9	8.6	8.9	7.6
30.0		6.4	8.2	8.8	9.2	8.1	8.4	7.1
32.0			6.2	7.6	8.1	7.7	8.0	6.7
34.0				5.7	6.4	7.0	7.6	6.4
36.0						6.3	6.7	6.0
38.0						4.9	5.3	5.7
40.0							4.1	5.3
42.0								4.5
θ(°)	65~84.5	64~84.5	65~84.5	66~84.5	67~84.5	67~84.5	66~84.5	68~84.5
標準フック	25t				25t		11.3t	
フック質量	870kg				870kg		440kg	
標準巻掛本数	3				2		1	

注)カウンタウエイト 58t、アウトリガ張出幅 6.8m
 または、カウンタウエイト 47t、アウトリガ張出幅 8.5m
 または、カウンタウエイト 47t、アウトリガ張出幅 8.0m

■IFG性能

TRA+ICA+55. 6mブーム+1. 6mフルオートラフィングジブ 単位:t

ジブ長さ(m)	10.3m		17.2m		24.1m		31.0m	
	オフセット		オフセット		オフセット		オフセット	
	5°	15°	5°	15°	5°	15°	5°	15°
11.0	18.5							
12.0	18.5							
14.0	18.5	16.9	15.9					
16.0	17.7	15.9	14.8		11.3			
18.0	16.6	15.0	13.9	11.9	11.3		9.0	
20.0	15.7	14.0	13.0	11.1	11.3		9.0	
22.0	14.4	13.2	12.1	10.4	10.8	9.1	9.0	
24.0	12.5	11.8	11.3	9.8	10.1	8.5	8.9	
26.0	10.9	10.3	10.6	9.2	9.4	8.0	8.2	6.9
28.0	8.5	9.0	9.3	8.7	8.8	7.5	7.7	6.5
30.0	6.2	7.1	8.2	7.8	8.2	7.1	7.2	6.1
32.0			6.5	6.9	7.5	6.6	6.7	5.7
34.0				6.0	6.6	6.3	6.3	5.3
36.0					5.3	5.7	5.9	5.0
38.0						5.0	5.3	4.7
40.0								4.5
42.0								4.1
θ(°)	66~84.5	67~84.5	68~84.5	68~84.5	68~84.5	69~84.5	70~84.5	70~84.5
標準フック	25t				11.3t			
フック質量	870kg				440kg			
標準巻掛本数	2				1			

注)カウンタウエイト 58t、アウトリガ張出幅 6.8m
 または、カウンタウエイト 47t、アウトリガ張出幅 8.5m
 または、カウンタウエイト 47t、アウトリガ張出幅 8.0m

■IFG性能

TRA+ICA+60. 0mブーム+1. 6mフルオートラフィングジブ 単位:t

ジブ長さ(m)	10.3m		17.2m		24.1m		31.0m	
	オフセット		オフセット		オフセット		オフセット	
	5°	15°	5°	15°	5°	15°	5°	15°
12.0	17.0							
14.0	17.0	15.6	11.0					
16.0	16.3	14.6	11.0					
18.0	15.3	13.6	11.0	11.0	9.5			
20.0	14.4	12.8	11.0	10.7	9.5		8.0	
22.0	13.4	12.1	11.0	10.0	9.5	8.4	8.0	
24.0	11.6	10.9	10.9	9.4	9.3	7.9	8.0	
26.0	10.0	9.5	10.2	8.8	8.7	7.4	7.7	6.4
28.0	8.4	8.2	9.0	8.3	8.1	6.9	7.2	6.0
30.0		7.0	7.8	7.5	7.6	6.5	6.7	5.6
32.0			6.6	6.5	6.9	6.1	6.2	5.3
34.0				5.6	6.0	5.8	5.8	4.9
36.0						5.1	5.5	4.6
38.0								4.4
40.0								4.1
θ(°)	69~84.5	69~84.5	70~84.5	70~84.5	71~84.5	72~84.5	72~84.5	73~84.5
標準フック	25t				11.3t			
フック質量	870kg				440kg			
標準巻掛本数	2				1			

注)カウンタウエイト 58t、アウトリガ張出幅 6.8m
 または、カウンタウエイト 47t、アウトリガ張出幅 8.5m
 または、カウンタウエイト 47t、アウトリガ張出幅 8.0m

9. TRA+ラフィングジブ、 TRA+ラフィングジブ+エクステンションジブ定格総荷重表

1. 定格総荷重表の性能区分TLA～TLFは、下表のとおりです。

カウンタウエイト アウトリガ 張出幅	138 t	118 t	98 t	78 t	58 t
8.5m	TLA	TLB	TLD	TLE	TLF
8.0m	/	TLC	TLD	TLE	TLF
6.8m	/	/	/	TLF	/

2. 定格総荷重は、つり具質量とフック質量（80トフック：1,270 kg、25トフック：870 kg、11.3トフック：440 kg）を含んだ値を示します。

3. 定格総荷重は、ブームのたわみを含んだ実際の作業半径に基づいています。

4. 各ブーム長さにおける各ブーム段の伸長状態（伸長割合%）は、下表のとおりです。

ブーム長さ	35.3m	40.4m	45.4m	50.5m	55.6m
伸縮ブーム1	90	90	90	90	90
伸縮ブーム2	90	90	90	90	90
伸縮ブーム3	0	45	90	90	90
伸縮ブーム4	0	0	0	45	90

5. ブーム長さ 35.3m未満での性能設定はありません。また、Bピン（ブーム固定ピン）を挿入していない状態では使用できません。

6. 定格総荷重表中の標準巻掛本数よりも少ない本数で使用する場合

・巻掛本数の下限および最大荷重の上限は下表のとおりです。

ジブ長さ	20 m	29 m
最小巻掛本数	3本	2本
最大荷重	33.5 t	22.5 t

7. 定格総荷重は、アウトリガを水平堅土上に設置したときの値です。

8. 定格総荷重表は、風による影響を含んでいません。瞬間最大風速が10m/s以上の風速では、クレーン作業を中止してください。

9. 定格総荷重表中の太線より上側はクレーンの強度に、下側はクレーンの安定に基づいています。

10. 「θ」は、無負荷状態で作動可能なジブオフセット角度範囲を示します。

オフセットは下図のようにブームの中心線とジブの中心線とのなす角度を示します。

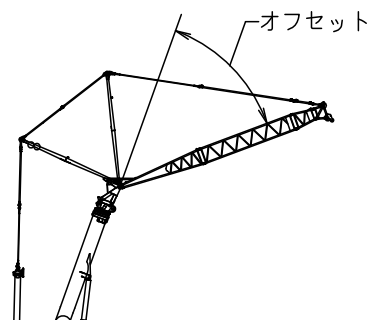

●TLA性能

TRA+2.1m+20mラフィングジブ

単位:t

ブーム長さ	35.3m			40.4m			45.4m			50.5m			55.6m	
ブーム起伏角 作業半径(m)	75°	65°	55°	75°	65°	75°	65°	83°	75°	65°	83°	75°		
16.0								11.9				7.5		
18.0								11.9				7.5		
20.0	34.6							11.9				7.5		
22.0	34.6			29.2				11.9				7.5		
24.0	34.6			29.2		18.8		11.9				7.5		
26.0	34.6			29.2		18.8			11.9					
28.0	33.8	30.7		29.2		18.8			11.9				7.5	
30.0		28.7				18.8			11.9				7.5	
32.0		26.9			25.1				11.9				7.5	
34.0		25.1			23.6		18.8							
36.0			20.4		22.2		18.8				11.9			
38.0			19.2				18.8				11.9			
40.0			18.0								11.9			
θ(°)	5~50	5~40	5~34	5~39	5~36	5~41	5~33	5~45	5~42	5~29	5~39	5~32		
標準フック	80t			80t			25t							
フック質量	1270kg			1270kg			870kg							
標準巻掛本数	4			3			3							

注)カウンタウエイト 138t、アウトリガ張出幅 8.5m

●TLA性能

TRA+2.1m+29mラフィングジブ

単位:t

ブーム長さ	35.3m			40.4m			45.4m			50.5m				55.6m					
ブーム起伏角 作業半径(m)	75°	65°	55°	83°	75°	65°	55°	83°	75°	65°	55°	83°	75°	65°	55°	83°	75°	65°	
16.0				20.3				13.4											
18.0				20.3				13.4				7.7						4.7	
20.0				20.3				13.4				7.7						4.7	
22.0	24.7			20.3				13.4				7.7						4.7	
24.0	24.7			20.3	20.3			13.4				7.7						4.7	
26.0	24.7			20.3	20.3			13.4	13.4			7.7						4.7	
28.0	24.7			20.3	20.3			13.4	13.4			7.7	7.7					4.7	
30.0	24.7			20.3	20.3			13.4	13.4			7.7	7.7					4.7	4.7
32.0	24.5	24.7			20.3			13.4	13.4			7.7	7.7					4.7	4.7
34.0	23.8	23.9			20.3				13.4				7.7					4.7	4.7
36.0	22.8	22.5			20.3	20.3			13.4				7.7					4.7	4.7
38.0		21.3			20.1	19.7			13.4	13.4			7.7					4.7	4.7
40.0		20.1				18.6				13.4			7.7					4.7	4.7
42.0		19.0	16.2			17.6				13.4				7.7				4.7	4.7
44.0			15.3			16.7				13.4				7.7					4.7
46.0			14.4			15.9	13.2			13.4				7.7					4.7
48.0			13.7				12.5			13.4				7.7					4.7
50.0							11.9					10.6		7.7					4.7
54.0												9.6					7.7		
58.0																7.6			
θ(°)	5~49	5~39	5~32	5~49	5~50	5~48	5~26	5~52	5~43	5~44	5~29	5~48	5~43	5~41	5~33	5~44	5~44	5~30	
標準フック	25t									25t									
フック質量	870kg									870kg									
標準巻掛本数	3									2									

注)カウンタウエイト 138t、アウトリガ張出幅 8.5m

●TLA性能

TRA+2.1m+38mラフィングジブ

単位:t

ブーム長さ	35.3m				40.4m				45.4m				50.5m			
ブーム起伏角 作業半径(m)	83°	75°	65°	55°	83°	75°	65°	55°	83°	75°	65°	55°	83°	75°	65°	55°
16.0	16.9															
18.0	16.9				13.4				9.0							
20.0	16.9				13.4				9.0				5.2			
22.0	16.9				13.4				9.0				5.2			
24.0	16.9				13.4				9.0				5.2			
26.0	16.9	16.9			13.4				9.0				5.2			
28.0	16.9	16.9			13.4	13.4			9.0				5.2			
30.0	16.9	16.9			13.4	13.4			9.0	9.0			5.2			
32.0	16.9	16.9			13.4	13.4			9.0	9.0			5.2	5.2		
34.0	16.7	16.9			13.4	13.4			9.0	9.0			5.2	5.2		
36.0	15.9	16.9			13.4	13.4			9.0	9.0			5.2	5.2		
38.0	15.2	16.9	16.9		13.4	13.4			9.0	9.0			5.2	5.2		
40.0		16.4	16.9			13.4	13.4		9.0	9.0			5.2	5.2		
42.0		15.6	16.9			13.4	13.4			9.0	9.0			5.2		
44.0		15.0	16.9			13.4	13.4			9.0	9.0			5.2		
46.0			16.3			13.4	13.4			9.0	9.0			5.2	5.2	
48.0			15.5	13.0			13.4			9.0	9.0			5.2	5.2	
50.0			14.7	12.3			13.4				9.0				5.2	
54.0				11.1			12.3	9.8			9.0				5.2	
58.0					10.0			8.9					7.6		5.2	5.2
62.0													6.9			5.2
66.0																5.2
θ(°)	5~54	5~49	5~39	5~41	5~50	5~50	5~45	5~27	5~53	5~51	5~35	5~29	5~50	5~44	5~40	5~31
標準フック	25t									25t						
フック質量	870kg									870kg						
標準巻掛本数	2									2						

注)カウンタウエイト 138t、アウトリガ張出幅 8.5m

●TLA性能

TRA+2.1m+47mラフィングジブ

単位:t

ブーム長さ ブーム起伏角 作業半径(m)	35.3m				40.4m				45.4m				50.5m			
	83°	75°	65°	55°	83°	75°	65°	55°	83°	75°	65°	55°	83°	75°	65°	55°
18.0	11.2				9.0											
20.0	11.2				9.0				6.2							
22.0	11.2				9.0				6.2				3.6			
24.0	11.2				9.0				6.2				3.6			
26.0	11.2				9.0				6.2				3.6			
28.0	11.2	11.2			9.0				6.2				3.6			
30.0	11.2	11.2			9.0	9.0			6.2				3.6			
32.0	11.2	11.2			9.0	9.0			6.2	6.2			3.6			
34.0	11.2	11.2			9.0	9.0			6.2	6.2			3.6	3.6		
36.0	11.2	11.2			9.0	9.0			6.2	6.2			3.6	3.6		
38.0	11.2	11.2			9.0	9.0			6.2	6.2			3.6	3.6		
40.0	11.2	11.2			9.0	9.0			6.2	6.2			3.6	3.6		
42.0	11.0	11.2	11.2		9.0	9.0			6.2	6.2			3.6	3.6		
44.0	10.4	11.2	11.2		9.0	9.0			6.2	6.2			3.6	3.6		
46.0	10.0	11.2	11.2		9.0	9.0	9.0		6.2	6.2			3.6	3.6		
48.0		10.7	11.2		9.0	9.0	9.0		6.2	6.2	6.2		3.6	3.6		
50.0		10.2	11.2			9.0	9.0			6.2	6.2			3.6	3.6	
54.0		9.4	10.8	10.0		9.0	9.0			6.2	6.2			3.6	3.6	
58.0			9.8	9.1			9.0	7.8			6.2			3.6	3.6	
62.0				8.2			9.0	7.0			6.2	5.7			3.6	
66.0				7.4				6.3			6.2	5.1			3.6	3.6
70.0								5.6				4.6				3.6
74.0																3.1
θ(°)	5~54	5~55	5~39	5~37	5~57	5~49	5~43	5~41	5~54	5~45	5~49	5~29	5~51	5~51	5~39	5~31
標準フック	25t															
フック質量	870kg															
標準巻掛本数	2															

注)カウンタウエイト 138t、アウトリガ張出幅 8.5m

●TLA性能

TRA+2.1m+47mラフィングジブ+9mエクステンションジブ

単位:t

ブーム長さ ブーム起伏角 作業半径(m)	35.3m				40.4m				45.4m				50.5m			
	83°	75°	65°	55°	83°	75°	65°	55°	83°	75°	65°	55°	83°	75°	65°	55°
22.0	6.9															
24.0	6.9				5.1				4.0							
26.0	6.9				5.1				4.0				2.7			
28.0	6.9				5.1				4.0				2.7			
30.0	6.9				5.1				4.0				2.7			
32.0	6.9				5.1				4.0				2.7			
34.0	6.9	6.9			5.1				4.0				2.7			
36.0	6.9	6.9			5.1	5.1			4.0				2.7			
38.0	6.9	6.9			5.1	5.1			4.0	4.0			2.7			
40.0	6.9	6.9			5.1	5.1			4.0	4.0			2.7	2.7		
42.0	6.9	6.9			5.1	5.1			4.0	4.0			2.7	2.7		
44.0	6.9	6.9			5.1	5.1			4.0	4.0			2.7	2.7		
46.0	6.9	6.9			5.1	5.1			4.0	4.0			2.7	2.7		
48.0	6.9	6.9	6.9		5.1	5.1			4.0	4.0			2.7	2.7		
50.0	6.9	6.9	6.9		5.1	5.1			4.0	4.0			2.7	2.7		
54.0		6.9	6.9		5.1	5.1	5.1		4.0	4.0	4.0		2.7	2.7		
58.0		6.9	6.9			5.1	5.1			4.0	4.0			2.7	2.7	
62.0			6.9	6.9			5.1	5.1			4.0			2.7	2.7	
66.0				6.8			5.1	5.1			4.0				2.7	
70.0					6.1			5.0				3.9			2.7	
74.0												3.4				2.3
78.0																2.0
θ(°)	5~44	5~42	5~28	5~23	5~50	5~39	5~31	5~17	5~48	5~35	5~26	5~18	5~46	5~39	5~29	5~19
標準フック	11.3t															
フック質量	440kg															
標準巻掛本数	1															

注)カウンタウエイト 138t、アウトリガ張出幅 8.5m

●TLA性能

TRA+2.1m+47mラフィングジブ+17mエクステンションジブ

単位:t

ブーム長さ ブーム起伏角 作業半径(m)	35.3m				40.4m				45.4m				50.5m			
	83°	75°	65°	55°	83°	75°	65°	55°	83°	75°	65°	55°	83°	75°	65°	55°
26.0	4.6															
28.0	4.6				3.4				2.6							
30.0	4.6				3.4				2.6				1.9			
32.0	4.6				3.4				2.6				1.9			
34.0	4.6				3.4				2.6				1.9			
36.0	4.6				3.4				2.6				1.9			
38.0	4.6	4.6			3.4				2.6				1.9			
40.0	4.6	4.6			3.4				2.6				1.9			
42.0	4.6	4.6			3.4	3.4			2.6	2.6			1.9			
44.0	4.6	4.6			3.4	3.4			2.6	2.6			1.9	1.9		
46.0	4.6	4.6			3.4	3.4			2.6	2.6			1.9	1.9		
48.0	4.6	4.6			3.4	3.4			2.6	2.6			1.9	1.9		
50.0	4.6	4.6			3.4	3.4			2.6	2.6			1.9	1.9		
54.0	4.6	4.6	4.6		3.4	3.4			2.6	2.6			1.9	1.9		
58.0	4.6	4.6	4.6		3.4	3.4	3.4		2.6	2.6			1.9	1.9		
62.0	4.6	4.6	4.6		3.4	3.4	3.4		2.6	2.6	2.6		1.9	1.9	1.9	
66.0		4.6	4.6			3.4	3.4			2.6	2.6			1.9	1.9	
70.0			4.6	4.6		3.4	3.4			2.6	2.6			1.9	1.9	
74.0				4.6	4.6		3.4	3.4			2.6	2.6			1.9	1.9
78.0					4.6			3.4			2.6	2.6			1.9	1.8
82.0								3.4				2.5				1.5
86.0												2.1				
θ(°)	5~53	5~43	5~37	5~24	5~51	5~48	5~32	5~26	5~49	5~44	5~35	5~27	5~47	5~40	5~30	5~14
標準フック	11.3t															
フック質量	440kg															
標準巻掛本数	1															

注)カウンタウエイト 138t、アウトリガ張出幅 8.5m

●TLA性能

TRA+2.1m+47mラフingジブ+25mエクステンションジブ

単位:t

ブーム長さ ブーム起伏角 作業半径(m)	35.3m				40.4m				45.4m				50.5m		
	83°	75°	65°	55°	83°	75°	65°	55°	83°	75°	65°	55°	83°	75°	65°
26.0	3.0														
28.0	3.0				2.1										
30.0	3.0				2.1				1.6					1.3	
32.0	3.0				2.1				1.6					1.3	
34.0	3.0				2.1				1.6					1.3	
36.0	3.0				2.1				1.6					1.3	
38.0	3.0				2.1				1.6					1.3	
40.0	3.0	3.0			2.1				1.6					1.3	
42.0	3.0	3.0			2.1				1.6					1.3	
44.0	3.0	3.0			2.1	2.1			1.6	1.6				1.3	
46.0	3.0	3.0			2.1	2.1			1.6	1.6				1.3	1.3
48.0	3.0	3.0			2.1	2.1			1.6	1.6	1.6			1.3	1.3
50.0	3.0	3.0			2.1	2.1			1.6	1.6	1.6			1.3	1.3
54.0	3.0	3.0			2.1	2.1			1.6	1.6	1.6			1.3	1.3
58.0	3.0	3.0	3.0		2.1	2.1			1.6	1.6	1.6			1.3	1.3
62.0	3.0	3.0	3.0		2.1	2.1	2.1		1.6	1.6	1.6			1.3	1.3
66.0	3.0	3.0	3.0		2.1	2.1	2.1		1.6	1.6	1.6			1.3	1.3
70.0	3.0	3.0	3.0		2.1	2.1	2.1		1.6	1.6	1.6			1.3	1.3
74.0		3.0	3.0	3.0		2.1	2.1			1.6	1.6			1.3	1.3
78.0		3.0	3.0	3.0		2.1	2.1	2.1		1.6	1.6			1.3	1.3
82.0			3.0	3.0			2.1	2.1			1.6	1.6		1.3	1.3
86.0				3.0			2.1	2.1			1.6	1.6			
90.0				3.0				2.1				1.6			
θ(°)	5~55	5~53	5~39	5~35	5~53	5~49	5~42	5~27	5~51	5~46	5~37	5~22	5~49	5~50	5~26
標準フック	11.3t														
フック質量	440kg														
標準巻掛本数	1														

注)カウンタウエイト 138t、アウトリガ張出幅 8.5m

●TLB性能

TRA+2.1m+20mラフingジブ

単位:t

ブーム長さ ブーム起伏角 作業半径(m)	35.3m				40.4m				45.4m				50.5m			55.6m	
	83°	75°	65°	55°	83°	75°	65°	55°	83°	75°	65°	55°	83°	75°	65°		
11.0	34.6																
12.0	34.6																
14.0	34.6				29.2				18.8								
16.0	34.6				29.2				18.8			11.9			7.5		
18.0	34.6				29.2				18.8			11.9			7.5		
20.0	34.6	34.6			29.2				18.8			11.9			7.5		
22.0	34.6	34.6			29.2	29.2			18.8			11.9			7.5		
24.0		34.6				29.2			18.8			11.9			7.5		
26.0		34.6				29.2			18.8			11.9					
28.0		33.6	29.1			29.2			18.8			11.9			7.5		
30.0			27.0						18.8			11.9			7.5		
32.0			25.2				24.0					11.9			7.5		
34.0			23.4				22.2				18.8						
36.0				18.2			20.6				18.8			11.9			
38.0				17.0							18.1			11.9			
40.0				15.8								11.9					
θ(°)	5~51	5~50	5~40	5~34	5~46	5~39	5~36	5~41	5~41	5~33	5~45	5~42	5~29	5~39	5~32		
標準フック	80t				80t				25t								
フック質量	1270kg				1270kg				870kg								
標準巻掛本数	4				3				3								

注)カウンタウエイト 118t、アウトリガ張出幅 8.5m

●TLB性能

TRA+2.1m+29mラフingジブ

単位:t

ブーム長さ ブーム起伏角 作業半径(m)	35.3m				40.4m				45.4m				50.5m				55.6m			
	83°	75°	65°	55°	83°	75°	65°	55°	83°	75°	65°	55°	83°	75°	65°	55°	83°	75°	65°	
14.0	24.7																			
16.0	24.7				20.3				13.4											
18.0	24.7				20.3				13.4				7.7						4.7	
20.0	24.7				20.3				13.4				7.7						4.7	
22.0	24.7	24.7			20.3				13.4				7.7						4.7	
24.0	24.7	24.7			20.3	20.3			13.4				7.7						4.7	
26.0	24.7	24.7			20.3	20.3			13.4	13.4			7.7						4.7	
28.0	24.1	24.7			20.3	20.3			13.4	13.4			7.7	7.7					4.7	
30.0	23.2	24.7			20.3	20.3			13.4	13.4			7.7	7.7					4.7	4.7
32.0		24.5	24.3			20.3			13.4	13.4			7.7	7.7					4.7	4.7
34.0		23.8	22.7			20.3			13.4	13.4			7.7	7.7					4.7	4.7
36.0		22.8	21.1			20.3	19.8			13.4			7.7						4.7	4.7
38.0			19.6			20.1	18.4			13.4	13.4			7.7					4.7	4.7
40.0			18.3				17.2				13.4			7.7					4.7	4.7
42.0			17.2	14.0			16.1				13.4					7.7			4.7	4.7
44.0				13.2			15.1				13.4					7.7				4.7
46.0				12.3			14.2	11.1			13.3					7.7				4.7
48.0				11.6				10.4			12.5					7.7				4.7
50.0								9.8					8.5			7.7				4.7
54.0													7.4						6.3	
58.0																			5.4	
θ(°)	5~53	5~49	5~39	5~32	5~49	5~50	5~48	5~26	5~52	5~43	5~44	5~29	5~48	5~43	5~41	5~33	5~44	5~44	5~30	
標準フック	25t				25t				25t				25t							
フック質量	870kg				870kg				870kg				870kg							
標準巻掛本数	3				3				2				2							

注)カウンタウエイト 118t、アウトリガ張出幅 8.5m

●TLB性能

TRA+2.1m+38mラフィングジブ

単位:t

ブーム長さ	35.3m				40.4m				45.4m				50.5m			
ブーム起伏角 作業半径 (m)	83°	75°	65°	55°	83°	75°	65°	55°	83°	75°	65°	55°	83°	75°	65°	55°
16.0	16.9															
18.0	16.9				13.4				9.0							
20.0	16.9				13.4				9.0				5.2			
22.0	16.9				13.4				9.0				5.2			
24.0	16.9				13.4				9.0				5.2			
26.0	16.9	16.9			13.4				9.0				5.2			
28.0	16.9	16.9			13.4	13.4			9.0				5.2			
30.0	16.9	16.9			13.4	13.4			9.0	9.0			5.2			
32.0	16.9	16.9			13.4	13.4			9.0	9.0			5.2	5.2		
34.0	16.7	16.9			13.4	13.4			9.0	9.0			5.2	5.2		
36.0	15.9	16.9			13.4	13.4			9.0	9.0			5.2	5.2		
38.0	15.2	16.9	16.9		13.4	13.4			9.0	9.0			5.2	5.2		
40.0		16.4	16.9			13.4	13.4		9.0	9.0			5.2	5.2		
42.0		15.8	16.6			13.4	13.4			9.0	9.0			5.2		
44.0		15.0	15.6			13.4	13.4			9.0	9.0			5.2		
46.0			14.7			13.4	13.4			9.0	9.0			5.2	5.2	
48.0			13.8	11.0			12.8			9.0	9.0			5.2	5.2	
50.0			13.0	10.3			12.1				9.0				5.2	
54.0				9.2			10.8	7.9			9.0				5.2	
58.0				8.1				6.9				5.6			5.2	4.4
62.0												4.8				3.7
66.0																3.1
θ (°)	5~54	5~49	5~39	5~41	5~50	5~50	5~45	5~27	5~53	5~51	5~35	5~29	5~50	5~44	5~40	5~31
標準フック	25t															
フック質量	870kg															
標準巻掛本数	2															

注)カウンタウエイト 118t、アウトリガ張出幅 8.5m

●TLB性能

TRA+2.1m+47mラフィングジブ

単位:t

ブーム長さ	35.3m				40.4m				45.4m				50.5m		
ブーム起伏角 作業半径 (m)	83°	75°	65°	55°	83°	75°	65°	55°	83°	75°	65°	55°	83°	75°	65°
18.0	11.2				9.0										
20.0	11.2				9.0				6.2						
22.0	11.2				9.0				6.2				3.6		
24.0	11.2				9.0				6.2				3.6		
26.0	11.2				9.0				6.2				3.6		
28.0	11.2	11.2			9.0	9.0			6.2				3.6		
30.0	11.2	11.2			9.0	9.0			6.2				3.6		
32.0	11.2	11.2			9.0	9.0			6.2	6.2			3.6		
34.0	11.2	11.2			9.0	9.0			6.2	6.2			3.6	3.6	
36.0	11.2	11.2			9.0	9.0			6.2	6.2			3.6	3.6	
38.0	11.2	11.2			9.0	9.0			6.2	6.2			3.6	3.6	
40.0	11.2	11.2			9.0	9.0			6.2	6.2			3.6	3.6	
42.0	11.0	11.2	11.2		9.0	9.0			6.2	6.2			3.6	3.6	
44.0	10.4	11.2	11.2		9.0	9.0			6.2	6.2			3.6	3.6	
46.0	10.0	11.2	11.2		9.0	9.0	9.0		6.2	6.2			3.6	3.6	
48.0		10.7	11.2		9.0	9.0	9.0		6.2	6.2	6.2		3.6	3.6	
50.0		10.2	11.2			9.0	9.0			6.2	6.2			3.6	3.6
54.0		9.4	10.8	8.3		9.0	9.0			6.2	6.2			3.6	3.6
58.0			9.8	7.2			9.0	5.9			6.2			3.6	3.6
62.0				6.3				8.0	5.1			6.2	3.8		3.6
66.0				5.5					4.3				6.2	3.2	3.6
70.0									3.7					2.6	
θ (°)	5~54	5~55	5~39	5~37	5~57	5~49	5~43	5~41	5~54	5~45	5~49	5~29	5~51	5~51	5~39
標準フック	25t														
フック質量	870kg														
標準巻掛本数	2														

注)カウンタウエイト 118t、アウトリガ張出幅 8.5m

●TLB性能

TRA+2.1m+47mラフィングジブ+9mエクステンションジブ

単位:t

ブーム長さ	35.3m				40.4m				45.4m				50.5m		
ブーム起伏角 作業半径 (m)	83°	75°	65°	55°	83°	75°	65°	55°	83°	75°	65°	55°	83°	75°	65°
22.0	6.9														
24.0	6.9				5.1				4.0						
26.0	6.9				5.1				4.0				2.7		
28.0	6.9				5.1				4.0				2.7		
30.0	6.9				5.1				4.0				2.7		
32.0	6.9				5.1				4.0				2.7		
34.0	6.9	6.9			5.1				4.0				2.7		
36.0	6.9	6.9			5.1	5.1			4.0				2.7		
38.0	6.9	6.9			5.1	5.1			4.0	4.0			2.7		
40.0	6.9	6.9			5.1	5.1			4.0	4.0			2.7	2.7	
42.0	6.9	6.9			5.1	5.1			4.0	4.0			2.7	2.7	
44.0	6.9	6.9			5.1	5.1			4.0	4.0			2.7	2.7	
46.0	6.9	6.9			5.1	5.1			4.0	4.0			2.7	2.7	
48.0	6.9	6.9	6.9		5.1	5.1			4.0	4.0			2.7	2.7	
50.0	6.9	6.9	6.9		5.1	5.1			4.0	4.0			2.7	2.7	
54.0		6.9	6.9		5.1	5.1	5.1		4.0	4.0	4.0		2.7	2.7	
58.0		6.9	6.9			5.1	5.1			4.0	4.0			2.7	2.7
62.0			6.9	5.9			5.1				4.0			2.7	2.7
66.0				5.0			5.1	3.9				4.0			2.7
70.0				4.3				3.2					2.0		2.7
74.0													1.5		
θ (°)	5~44	5~42	5~28	5~23	5~50	5~39	5~31	5~17	5~48	5~35	5~26	5~18	5~46	5~39	5~29
標準フック	11.3t														
フック質量	440kg														
標準巻掛本数	1														

注)カウンタウエイト 118t、アウトリガ張出幅 8.5m

●TLB性能

TRA+2. 1m+47mラフingジブ+17mエクステンションジブ

単位:t

ブーム長さ ブーム起伏角 作業半径(m)	35.3m				40.4m				45.4m			50.5m		
	83°	75°	65°	55°	83°	75°	65°	55°	83°	75°	65°	83°	75°	65°
26.0	4.6													
28.0	4.6				3.4				2.6					
30.0	4.6				3.4				2.6			1.9		
32.0	4.6				3.4				2.6			1.9		
34.0	4.6				3.4				2.6			1.9		
36.0	4.6				3.4				2.6			1.9		
38.0	4.6	4.6			3.4				2.6			1.9		
40.0	4.6	4.6			3.4				2.6			1.9		
42.0	4.6	4.6			3.4	3.4			2.6	2.6		1.9		
44.0	4.6	4.6			3.4	3.4			2.6	2.6		1.9	1.9	
46.0	4.6	4.6			3.4	3.4			2.6	2.6		1.9	1.9	
48.0	4.6	4.6			3.4	3.4			2.6	2.6		1.9	1.9	
50.0	4.6	4.6			3.4	3.4			2.6	2.6		1.9	1.9	
54.0	4.6	4.6	4.6		3.4	3.4			2.6	2.6		1.9	1.9	
58.0	4.6	4.6	4.6		3.4	3.4	3.4		2.6	2.6		1.9	1.9	
62.0	4.6	4.6	4.6		3.4	3.4	3.4		2.6	2.6	2.6	1.9	1.9	1.9
66.0		4.6	4.6			3.4	3.4			2.6	2.6	2.6	1.9	1.9
70.0			4.6	4.5		3.4	3.4			2.6	2.6		1.9	1.9
74.0			4.6	3.9			3.4	2.8			2.6			1.9
78.0				3.3				2.3			2.6			1.9
82.0								1.8						
θ(°)	5~53	5~43	5~37	5~24	5~51	5~48	5~32	5~26	5~49	5~44	5~35	5~47	5~40	5~30
標準フック	11.3t													
フック質量	440kg													
標準巻掛本数	1													

注)カウンタウエイト 118t、アウトリガ張出幅 8.5m

●TLB性能

TRA+2. 1m+47mラフingジブ+25mエクステンションジブ

単位:t

ブーム長さ ブーム起伏角 作業半径(m)	35.3m				40.4m				45.4m			50.5m		
	83°	75°	65°	55°	83°	75°	65°	55°	83°	75°	65°	83°	75°	65°
26.0	3.0													
28.0	3.0				2.1									
30.0	3.0				2.1				1.6			1.3		
32.0	3.0				2.1				1.6			1.3		
34.0	3.0				2.1				1.6			1.3		
36.0	3.0				2.1				1.6			1.3		
38.0	3.0				2.1				1.6			1.3		
40.0	3.0	3.0			2.1				1.6			1.3		
42.0	3.0	3.0			2.1				1.6			1.3		
44.0	3.0	3.0			2.1	2.1			1.6	1.6		1.3		
46.0	3.0	3.0			2.1	2.1			1.6	1.6		1.3	1.3	
48.0	3.0	3.0			2.1	2.1			1.6	1.6		1.3	1.3	
50.0	3.0	3.0			2.1	2.1			1.6	1.6		1.3	1.3	
54.0	3.0	3.0			2.1	2.1			1.6	1.6		1.3	1.3	
58.0	3.0	3.0	3.0		2.1	2.1			1.6	1.6		1.3	1.3	
62.0	3.0	3.0	3.0		2.1	2.1	2.1		1.6	1.6		1.3	1.3	
66.0	3.0	3.0	3.0		2.1	2.1	2.1		1.6	1.6	1.6	1.3	1.3	1.3
70.0	3.0	3.0	3.0		2.1	2.1	2.1		1.6	1.6	1.6	1.3	1.3	1.3
74.0		3.0	3.0	3.0		2.1	2.1			1.6	1.6		1.3	1.3
78.0		3.0	3.0	3.0		2.1	2.1	2.1		1.6	1.6		1.3	1.3
82.0			3.0	2.8			2.1	1.8			1.6		1.3	1.3
86.0				2.3				2.1			1.6			
90.0				1.9										
θ(°)	5~55	5~53	5~39	5~35	5~53	5~49	5~42	5~15	5~51	5~46	5~37	5~49	5~50	5~26
標準フック	11.3t													
フック質量	440kg													
標準巻掛本数	1													

注)カウンタウエイト 118t、アウトリガ張出幅 8.5m

●TLC性能

TRA+2. 1m+20mラフingジブ

単位:t

ブーム長さ ブーム起伏角 作業半径(m)	35.3m				40.4m			45.4m			50.5m			55.6m		
	83°	75°	65°	55°	83°	75°	65°	83°	75°	65°	83°	75°	65°	83°	75°	
11.0	34.6															
12.0	34.6															
14.0	34.6				29.2			18.8								
16.0	34.6				29.2			18.8			11.9			7.5		
18.0	34.6				29.2			18.8			11.9			7.5		
20.0	34.6	34.6			29.2			18.8			11.9			7.5		
22.0	34.6	34.6			29.2	29.2		18.8			11.9			7.5		
24.0		34.6				29.2			18.8		11.9			7.5		
26.0		34.6				29.2			18.8			11.9				
28.0		32.8	28.4			29.2			18.8			11.9			7.5	
30.0			26.3						18.8			11.9			7.5	
32.0			24.5					23.3				11.9			7.5	
34.0			22.8					21.7		18.8						
36.0				18.2				20.3		18.8			11.9			
38.0				17.0						18.1			11.9			
40.0				15.8									11.9			
θ(°)	5~51	5~50	5~40	5~34	5~46	5~39	5~36	5~41	5~41	5~33	5~45	5~42	5~29	5~39	5~32	
標準フック	80t				80t						25t					
フック質量	1270kg				1270kg						870kg					
標準巻掛本数	4				3						3					

注)カウンタウエイト 118t、アウトリガ張出幅 8.0m

●TLC性能

TRA+2. 1m+29mラフィングジブ

単位:t

ブーム長さ	35.3m				40.4m				45.4m				50.5m				55.6m			
ブーム起伏角 作業半径(m)	83°	75°	65°	55°	83°	75°	65°	55°	83°	75°	65°	55°	83°	75°	65°	55°	83°	75°	65°	
14.0	24.7																			
16.0	24.7				20.3				13.4											
18.0	24.7				20.3				13.4				7.7				4.7			
20.0	24.7				20.3				13.4				7.7				4.7			
22.0	24.7	24.7			20.3				13.4				7.7				4.7			
24.0	24.7	24.7			20.3	20.3			13.4				7.7				4.7			
26.0	24.7	24.7			20.3	20.3			13.4	13.4			7.7				4.7			
28.0	24.1	24.7			20.3	20.3			13.4	13.4			7.7	7.7			4.7			
30.0	23.2	24.7			20.3	20.3			13.4	13.4			7.7	7.7			4.7	4.7		
32.0		24.5	23.6			20.3			13.4	13.4			7.7	7.7			4.7	4.7		
34.0		23.8	22.0			20.3				13.4				7.7				4.7		
36.0		22.8	20.6			20.3	19.4			13.4				7.7				4.7		
38.0			19.3			20.1	18.2			13.4	13.4			7.7				4.7		
40.0			18.2				17.1				13.4			7.7				4.7		
42.0			17.1	14.0			16.1				13.4				7.7			4.7		
44.0				13.2			15.1				13.4				7.7			4.7		
46.0				12.3			14.2	10.9			13.3				7.7			4.7		
48.0				11.6				10.2			12.5				7.7			4.7		
50.0								9.5							7.7			4.7		
54.0													8.2							
58.0													7.1				5.9			
θ(°)	5~53	5~49	5~39	5~32	5~49	5~50	5~48	5~26	5~52	5~43	5~44	5~29	5~48	5~43	5~41	5~33	5~44	5~44	5~30	
標準フック	25t								25t											
フック質量	870kg								870kg											
標準巻掛本数	3								2											

注)カウンタウエイト 118t、アウトリガ張出幅 8.0m

●TLC性能

TRA+2. 1m+38mラフィングジブ

単位:t

ブーム長さ	35.3m				40.4m				45.4m				50.5m			
ブーム起伏角 作業半径(m)	83°	75°	65°	55°	83°	75°	65°	55°	83°	75°	65°	55°	83°	75°	65°	55°
16.0	16.9															
18.0	16.9				13.4				9.0							
20.0	16.9				13.4				9.0				5.2			
22.0	16.9				13.4				9.0				5.2			
24.0	16.9				13.4				9.0				5.2			
26.0	16.9	16.9			13.4				9.0				5.2			
28.0	16.9	16.9			13.4	13.4			9.0				5.2			
30.0	16.9	16.9			13.4	13.4			9.0	9.0			5.2			
32.0	16.9	16.9			13.4	13.4			9.0	9.0			5.2	5.2		
34.0	16.7	16.9			13.4	13.4			9.0	9.0			5.2	5.2		
36.0	15.9	16.9			13.4	13.4			9.0	9.0			5.2	5.2		
38.0	15.2	16.9	16.9		13.4	13.4			9.0	9.0			5.2	5.2		
40.0		16.4	16.9			13.4	13.4		9.0	9.0			5.2	5.2		
42.0		15.6	16.5			13.4	13.4			9.0	9.0			5.2		
44.0		15.0	15.6			13.4	13.4			9.0	9.0			5.2		
46.0			14.7			13.4	13.4			9.0	9.0			5.2	5.2	
48.0			13.8	10.9			12.8			9.0	9.0			5.2	5.2	
50.0			13.0	10.2			12.1				9.0				5.2	
54.0				8.9			10.8	7.6			9.0				5.2	
58.0				7.8				6.6					5.3		5.2	4.1
62.0													4.5			3.4
66.0																2.8
θ(°)	5~54	5~49	5~39	5~41	5~50	5~50	5~45	5~27	5~53	5~51	5~35	5~29	5~50	5~44	5~40	5~31
標準フック	25t								25t							
フック質量	870kg								870kg							
標準巻掛本数	2								2							

注)カウンタウエイト 118t、アウトリガ張出幅 8.0m

●TLC性能

TRA+2. 1m+47mラフィングジブ

単位:t

ブーム長さ	35.3m				40.4m				45.4m				50.5m		
ブーム起伏角 作業半径(m)	83°	75°	65°	55°	83°	75°	65°	55°	83°	75°	65°	55°	83°	75°	65°
18.0	11.2				9.0										
20.0	11.2				9.0				6.2						
22.0	11.2				9.0				6.2				3.6		
24.0	11.2				9.0				6.2				3.6		
26.0	11.2				9.0				6.2				3.6		
28.0	11.2	11.2			9.0				6.2				3.6		
30.0	11.2	11.2			9.0	9.0			6.2				3.6		
32.0	11.2	11.2			9.0	9.0			6.2	6.2			3.6		
34.0	11.2	11.2			9.0	9.0			6.2	6.2			3.6	3.6	
36.0	11.2	11.2			9.0	9.0			6.2	6.2			3.6	3.6	
38.0	11.2	11.2			9.0	9.0			6.2	6.2			3.6	3.6	
40.0	11.2	11.2			9.0	9.0			6.2	6.2			3.6	3.6	
42.0	11.0	11.2	11.2		9.0	9.0			6.2	6.2			3.6	3.6	
44.0	10.4	11.2	11.2		9.0	9.0			6.2	6.2			3.6	3.6	
46.0	10.0	11.2	11.2		9.0	9.0	9.0		6.2	6.2			3.6	3.6	
48.0		10.7	11.2		9.0	9.0	9.0		6.2	6.2	6.2		3.6	3.6	
50.0		10.2	11.2			9.0	9.0			6.2	6.2			3.6	3.6
54.0		9.4	10.8	8.0		9.0	9.0			6.2	6.2			3.6	3.6
58.0			9.8	7.0			8.9	5.6			6.2			3.6	3.6
62.0				6.1			7.8	4.8			6.2	3.5			3.6
66.0				5.2				4.1				5.9	2.9		3.6
70.0								3.4					2.3		
θ(°)	5~54	5~55	5~39	5~37	5~57	5~49	5~43	5~41	5~54	5~45	5~49	5~29	5~51	5~51	5~39
標準フック	25t								25t						
フック質量	870kg								870kg						
標準巻掛本数	2								2						

注)カウンタウエイト 118t、アウトリガ張出幅 8.0m

●TLC性能

TRA+2.1m+47mラフィングジブ+9mエクステンションジブ

単位:t

ブーム長さ	35.3m				40.4m				45.4m			50.5m		
ブーム起伏角 作業半径(m)	83°	75°	65°	55°	83°	75°	65°	55°	83°	75°	65°	83°	75°	65°
22.0	6.9													
24.0	6.9				5.1				4.0					
26.0	6.9				5.1				4.0				2.7	
28.0	6.9				5.1				4.0				2.7	
30.0	6.9				5.1				4.0				2.7	
32.0	6.9				5.1				4.0				2.7	
34.0	6.9	6.9			5.1				4.0				2.7	
36.0	6.9	6.9			5.1	5.1			4.0				2.7	
38.0	6.9	6.9			5.1	5.1			4.0	4.0			2.7	
40.0	6.9	6.9			5.1	5.1			4.0	4.0			2.7	2.7
42.0	6.9	6.9			5.1	5.1			4.0	4.0			2.7	2.7
44.0	6.9	6.9			5.1	5.1			4.0	4.0			2.7	2.7
46.0	6.9	6.9			5.1	5.1			4.0	4.0			2.7	2.7
48.0	6.9	6.9	6.9		5.1	5.1			4.0	4.0			2.7	2.7
50.0	6.9	6.9	6.9		5.1	5.1			4.0	4.0			2.7	2.7
54.0		6.9	6.9		5.1	5.1	5.1		4.0	4.0	4.0		2.7	2.7
58.0		6.9	6.9			5.1	5.1			4.0	4.0		4.0	2.7
62.0			6.9	5.6			5.1				4.0			2.7
66.0				4.8			5.1	3.6			4.0			2.7
70.0				4.1				3.0						2.7
θ(°)	5~44	5~42	5~28	5~23	5~50	5~39	5~31	5~17	5~48	5~35	5~26	5~48	5~39	5~29
標準フック	11.3t													
フック質量	440kg													
標準巻掛本数	1													

注)カウンタウエイト 118t、アウトリガ張出幅 8.0m

●TLC性能

TRA+2.1m+47mラフィングジブ+17mエクステンションジブ

単位:t

ブーム長さ	35.3m				40.4m				45.4m			50.5m		
ブーム起伏角 作業半径(m)	83°	75°	65°	55°	83°	75°	65°	55°	83°	75°	65°	83°	75°	65°
26.0	4.6													
28.0	4.6				3.4				2.6					
30.0	4.6				3.4				2.6				1.9	
32.0	4.6				3.4				2.6				1.9	
34.0	4.6				3.4				2.6				1.9	
36.0	4.6				3.4				2.6				1.9	
38.0	4.6	4.6			3.4				2.6				1.9	
40.0	4.6	4.6			3.4				2.6				1.9	
42.0	4.6	4.6			3.4	3.4			2.6	2.6			1.9	
44.0	4.6	4.6			3.4	3.4			2.6	2.6			1.9	1.9
46.0	4.6	4.6			3.4	3.4			2.6	2.6			1.9	1.9
48.0	4.6	4.6			3.4	3.4			2.6	2.6			1.9	1.9
50.0	4.6	4.6			3.4	3.4			2.6	2.6			1.9	1.9
54.0	4.6	4.6	4.6		3.4	3.4			2.6	2.6			1.9	1.9
58.0	4.6	4.6	4.6		3.4	3.4	3.4		2.6	2.6			1.9	1.9
62.0	4.6	4.6	4.6		3.4	3.4	3.4		2.6	2.6	2.6		1.9	1.9
66.0		4.6	4.6			3.4	3.4			2.6	2.6		1.9	1.9
70.0			4.6	4.3		3.4	3.4			2.6	2.6		1.9	1.9
74.0			4.6	3.6			3.4	2.5			2.6			1.9
78.0				3.1				2.0			2.6			1.9
82.0								1.6						
θ(°)	5~53	5~43	5~37	5~24	5~51	5~48	5~32	5~26	5~49	5~44	5~35	5~47	5~40	5~30
標準フック	11.3t													
フック質量	440kg													
標準巻掛本数	1													

注)カウンタウエイト 118t、アウトリガ張出幅 8.0m

●TLC性能

TRA+2.1m+47mラフィングジブ+25mエクステンションジブ

単位:t

ブーム長さ	35.3m				40.4m				45.4m			50.5m		
ブーム起伏角 作業半径(m)	83°	75°	65°	55°	83°	75°	65°	55°	83°	75°	65°	83°	75°	65°
26.0	3.0													
28.0	3.0				2.1									
30.0	3.0				2.1				1.6				1.3	
32.0	3.0				2.1				1.6				1.3	
34.0	3.0				2.1				1.6				1.3	
36.0	3.0				2.1				1.6				1.3	
38.0	3.0				2.1				1.6				1.3	
40.0	3.0	3.0			2.1				1.6				1.3	
42.0	3.0	3.0			2.1				1.6				1.3	
44.0	3.0	3.0			2.1	2.1			1.6	1.6			1.3	
46.0	3.0	3.0			2.1	2.1			1.6	1.6			1.3	1.3
48.0	3.0	3.0			2.1	2.1			1.6	1.6			1.3	1.3
50.0	3.0	3.0			2.1	2.1			1.6	1.6			1.3	1.3
54.0	3.0	3.0			2.1	2.1			1.6	1.6			1.3	1.3
58.0	3.0	3.0	3.0		2.1	2.1			1.6	1.6			1.3	1.3
62.0	3.0	3.0	3.0		2.1	2.1	2.1		1.6	1.6			1.3	1.3
66.0	3.0	3.0	3.0		2.1	2.1	2.1		1.6	1.6	1.6		1.3	1.3
70.0	3.0	3.0	3.0		2.1	2.1	2.1		1.6	1.6	1.6		1.3	1.3
74.0		3.0	3.0	3.0		2.1	2.1			1.6	1.6		1.3	1.3
78.0		3.0	3.0	3.0		2.1	2.1	2.0		1.6	1.6		1.3	1.3
82.0			3.0	2.6			2.1	1.6			1.6		1.3	1.3
86.0				2.1				2.1			1.6			
90.0				1.7										
θ(°)	5~55	5~53	5~39	5~35	5~53	5~49	5~42	5~15	5~51	5~46	5~37	5~49	5~50	5~26
標準フック	11.3t													
フック質量	440kg													
標準巻掛本数	1													

注)カウンタウエイト 118t、アウトリガ張出幅 8.0m

●TLD性能

TRA+2.1m+20mラフィングジブ

単位:t

ブーム長さ ブーム起伏角 作業半径 (m)	35.3m				40.4m				45.4m				50.5m			55.6m	
	83°	75°	65°	55°	83°	75°	65°	55°	83°	75°	65°	55°	83°	75°	65°	83°	75°
11.0	34.6																
12.0	34.6																
14.0	34.6				29.2			18.8									
16.0	34.6				29.2			18.8				11.9			7.5		
18.0	34.6				29.2			18.8				11.9			7.5		
20.0	34.6	34.6			29.2			18.8				11.9			7.5		
22.0	34.6	34.6			29.2	29.2		18.8				11.9			7.5		
24.0		34.6				29.2			18.8			11.9			7.5		
26.0		33.2				29.2			18.8				11.9				
28.0		30.2	25.1			29.1			18.8				11.9				7.5
30.0			23.0						18.8				11.9				7.5
32.0			21.1					19.7					11.9				7.5
34.0			19.5					18.2				17.0					
36.0				14.5				16.8				15.8				11.9	
38.0				13.5								14.6				11.9	
40.0				12.4												11.9	
θ (°)	5~51	5~50	5~40	5~34	5~46	5~39	5~36	5~41	5~41	5~33	5~45	5~42	5~29	5~39	5~32		
標準フック	80t				80t				25t								
フック質量	1270kg				1270kg				870kg								
標準巻掛本数	4				3				3								

注)カウンタウエイト 98t、アウトリガ張出幅 8.5m
または、カウンタウエイト 98t、アウトリガ張出幅 8.0m

●TLD性能

TRA+2.1m+29mラフィングジブ

単位:t

ブーム長さ ブーム起伏角 作業半径 (m)	35.3m				40.4m				45.4m				50.5m				55.6m		
	83°	75°	65°	55°	83°	75°	65°	55°	83°	75°	65°	55°	83°	75°	65°	55°	83°	75°	65°
14.0	24.7																		
16.0	24.7				20.3				13.4										
18.0	24.7				20.3				13.4				7.7					4.7	
20.0	24.7				20.3				13.4				7.7					4.7	
22.0	24.7	24.7			20.3				13.4				7.7					4.7	
24.0	24.7	24.7			20.3	20.3			13.4				7.7					4.7	
26.0	24.7	24.7			20.3	20.3			13.4	13.4			7.7					4.7	
28.0	24.1	24.7			20.3	20.3			13.4	13.4			7.7	7.7				4.7	
30.0	23.2	24.7			20.3	20.3			13.4	13.4			7.7	7.7				4.7	4.7
32.0		24.5	20.3			20.3			13.4	13.4			7.7	7.7				4.7	4.7
34.0		23.1	18.7			20.3			13.4	13.4			7.7	7.7				4.7	4.7
36.0		21.4	17.4			20.3	16.1		13.4	13.4			7.7	7.7				4.7	4.7
38.0			16.1			19.1	14.9		13.4	13.4			7.7	7.7				4.7	4.7
40.0			15.0				13.9			12.8			7.7	7.7				4.7	4.7
42.0			14.0		10.6		13.0			11.9				7.7				4.7	4.7
44.0				9.8			12.1			11.0				7.7					4.7
46.0				9.1			11.3	7.5		10.2				7.7					4.7
48.0				8.4				6.9		9.5				7.7					4.7
50.0								6.4					5.1	7.7					4.7
54.0													4.2				3.1		
58.0																	2.4		
θ (°)	5~53	5~49	5~39	5~32	5~49	5~50	5~48	5~26	5~52	5~43	5~44	5~29	5~48	5~43	5~41	5~33	5~44	5~44	5~30
標準フック	25t								25t										
フック質量	870kg								870kg										
標準巻掛本数	3								2										

注)カウンタウエイト 98t、アウトリガ張出幅 8.5m
または、カウンタウエイト 98t、アウトリガ張出幅 8.0m

●TLD性能

TRA+2.1m+38mラフィングジブ

単位:t

ブーム長さ ブーム起伏角 作業半径 (m)	35.3m				40.4m				45.4m				50.5m		
	83°	75°	65°	55°	83°	75°	65°	55°	83°	75°	65°	55°	83°	75°	65°
16.0	16.9														
18.0	16.9				13.4				9.0						
20.0	16.9				13.4				9.0				5.2		
22.0	16.9				13.4				9.0				5.2		
24.0	16.9				13.4				9.0				5.2		
26.0	16.9	16.9			13.4				9.0				5.2		
28.0	16.9	16.9			13.4	13.4			9.0				5.2		
30.0	16.9	16.9			13.4	13.4			9.0	9.0			5.2		
32.0	16.9	16.9			13.4	13.4			9.0	9.0			5.2	5.2	
34.0	16.7	16.9			13.4	13.4			9.0	9.0			5.2	5.2	
36.0	15.9	16.9			13.4	13.4			9.0	9.0			5.2	5.2	
38.0	15.2	16.9	15.5		13.4	13.4			9.0	9.0			5.2	5.2	
40.0		16.4	14.5			13.4	13.2		9.0	9.0			5.2	5.2	
42.0		15.6	13.5			13.4	12.4			9.0	9.0			5.2	
44.0		15.0	12.6			13.4	11.5			9.0	9.0			5.2	
46.0			11.8			13.4	10.7			9.0	9.0			5.2	5.2
48.0			11.1	7.6			9.9			9.0	8.7			5.2	5.2
50.0			10.4	7.1			9.3				8.0				5.2
54.0				6.1			8.0	4.7			6.9				5.2
58.0				5.1				3.9							5.2
62.0													2.6		
θ (°)	5~54	5~49	5~39	5~41	5~50	5~50	5~45	5~27	5~53	5~51	5~35	5~29	5~50	5~44	5~40
標準フック					25t										
フック質量					870kg										
標準巻掛本数					2										

注)カウンタウエイト 98t、アウトリガ張出幅 8.5m
または、カウンタウエイト 98t、アウトリガ張出幅 8.0m

●TLD性能

TRA+2.1m+47mラフingジブ

単位:t

ブーム長さ	35.3m				40.4m				45.4m			50.5m			
ブーム起伏角 作業半径(m)	83°	75°	65°	55°	83°	75°	65°	55°	83°	75°	65°	83°	75°	65°	
18.0	11.2				9.0										
20.0	11.2				9.0				6.2						
22.0	11.2				9.0				6.2				3.6		
24.0	11.2				9.0				6.2				3.6		
26.0	11.2				9.0				6.2				3.6		
28.0	11.2	11.2			9.0				6.2				3.6		
30.0	11.2	11.2			9.0	9.0			6.2				3.6		
32.0	11.2	11.2			9.0	9.0			6.2	6.2			3.6		
34.0	11.2	11.2			9.0	9.0			6.2	6.2			3.6	3.6	
36.0	11.2	11.2			9.0	9.0			6.2	6.2			3.6	3.6	
38.0	11.2	11.2			9.0	9.0			6.2	6.2			3.6	3.6	
40.0	11.2	11.2			9.0	9.0			6.2	6.2			3.6	3.6	
42.0	11.0	11.2	11.2		9.0	9.0			6.2	6.2			3.6	3.6	
44.0	10.4	11.2	11.2		9.0	9.0			6.2	6.2			3.6	3.6	
46.0	10.0	11.2	11.1		9.0	9.0	9.0		6.2	6.2			3.6	3.6	
48.0		10.7	10.3		9.0	9.0	9.0		6.2	6.2	6.2		3.6	3.6	
50.0		10.2	9.6			9.0	8.4			6.2	6.2	6.2		3.6	3.6
54.0		9.4	8.3	5.1		9.0	7.2			6.2	6.0			3.6	3.6
58.0			7.2	4.3			6.2	3.0			5.1			3.6	3.6
62.0				3.6				5.3	2.3			4.3			3.4
66.0				2.9								3.6			2.8
θ(°)	5~54	5~55	5~39	5~37	5~57	5~49	5~43	5~18	5~54	5~45	5~49	5~51	5~51	5~39	
標準フック	25t														
フック質量	870kg														
標準巻掛本数	2														

注)カウンタウエイト 98t、アウトリガ張出幅 8.5m
または、カウンタウエイト 98t、アウトリガ張出幅 8.0m

●TLD性能

TRA+2.1m+47mラフingジブ+9mエクステンションジブ

単位:t

ブーム長さ	35.3m				40.4m			45.4m			50.5m			
ブーム起伏角 作業半径(m)	83°	75°	65°	55°	83°	75°	65°	83°	75°	65°	83°	75°	65°	
22.0	6.9													
24.0	6.9				5.1			4.0						
26.0	6.9				5.1			4.0			2.7			
28.0	6.9				5.1			4.0			2.7			
30.0	6.9				5.1			4.0			2.7			
32.0	6.9				5.1			4.0			2.7			
34.0	6.9	6.9			5.1			4.0			2.7			
36.0	6.9	6.9			5.1	5.1		4.0			2.7			
38.0	6.9	6.9			5.1	5.1		4.0	4.0		2.7			
40.0	6.9	6.9			5.1	5.1		4.0	4.0		2.7	2.7		
42.0	6.9	6.9			5.1	5.1		4.0	4.0		2.7	2.7		
44.0	6.9	6.9			5.1	5.1		4.0	4.0		2.7	2.7		
46.0	6.9	6.9			5.1	5.1		4.0	4.0		2.7	2.7		
48.0	6.9	6.9	6.9		5.1	5.1		4.0	4.0		2.7	2.7		
50.0	6.9	6.9	6.9		5.1	5.1		4.0	4.0		2.7	2.7		
54.0		6.9	6.9		5.1	5.1	5.1	4.0	4.0	4.0	2.7	2.7		
58.0		6.9	6.9			5.1	5.1		4.0	4.0	2.7	2.7	2.7	
62.0			6.0	3.1			5.0			3.9		2.7	2.7	
66.0				2.5			4.2			3.2			2.4	
70.0				1.9									1.8	
θ(°)	5~44	5~42	5~28	5~23	5~50	5~39	5~31	5~48	5~35	5~26	5~46	5~39	5~29	
標準フック	11.3t													
フック質量	440kg													
標準巻掛本数	1													

注)カウンタウエイト 98t、アウトリガ張出幅 8.5m
または、カウンタウエイト 98t、アウトリガ張出幅 8.0m

●TLE性能

TRA+2.1m+20mラフingジブ

単位:t

ブーム長さ	35.3m				40.4m			45.4m			50.5m			55.6m		
ブーム起伏角 作業半径(m)	83°	75°	65°	55°	83°	75°	65°	83°	75°	65°	83°	75°	65°	83°	75°	
11.0	34.6															
12.0	34.6															
14.0	34.6				29.2			18.8								
16.0	34.6				29.2			18.8			11.9				7.5	
18.0	34.6				29.2			18.8			11.9				7.5	
20.0	34.6	34.6			29.2			18.8			11.9				7.5	
22.0	34.6	34.6			29.2	29.2		18.8			11.9				7.5	
24.0		31.0				29.2			18.8		11.9				7.5	
26.0		27.9				26.7			18.8			11.9				
28.0		25.2	20.1			24.1			18.8			11.9				
30.0			18.3						18.8			11.9			7.5	
32.0			16.7									11.9			7.5	
34.0			15.3													
36.0				10.1												
38.0				9.3											9.4	
40.0				8.4											8.6	
θ(°)	5~51	5~50	5~40	5~34	5~46	5~39	5~36	5~41	5~41	5~33	5~45	5~42	5~29	5~39	5~32	
標準フック	80t															
フック質量	1270kg				1270kg				870kg				25t			
標準巻掛本数	4				3				3				3			

注)カウンタウエイト 78t、アウトリガ張出幅 8.5m
または、カウンタウエイト 78t、アウトリガ張出幅 8.0m

●TLE性能

TRA+2.1m+29mラフingジブ

単位:t

ブーム長さ	35.3m				40.4m				45.4m			50.5m			55.6m		
ブーム起伏角 作業半径 (m)	83°	75°	65°	55°	83°	75°	65°	55°	83°	75°	65°	83°	75°	65°	83°	75°	65°
14.0	24.7																
16.0	24.7				20.3				13.4								
18.0	24.7				20.3				13.4			7.7				4.7	
20.0	24.7				20.3				13.4			7.7				4.7	
22.0	24.7	24.7			20.3				13.4			7.7				4.7	
24.0	24.7	24.7			20.3	20.3			13.4			7.7				4.7	
26.0	24.7	24.7			20.3	20.3			13.4	13.4		7.7				4.7	
28.0	24.1	24.7			20.3	20.3			13.4	13.4		7.7	7.7			4.7	
30.0	23.2	22.5			20.3	20.3			13.4	13.4		7.7	7.7			4.7	4.7
32.0		20.6	15.9			19.6			13.4	13.4		7.7	7.7			4.7	4.7
34.0		19.0	14.6			18.0				13.4			7.7				4.7
36.0		17.5	13.5			16.6	12.0			13.4			7.7				4.7
38.0			12.4			15.4	11.0			13.4			7.7				4.7
40.0			11.5				10.2					8.8		7.7			4.7
42.0			10.7	6.8			9.3					8.1			6.8		4.7
44.0				6.2			8.6					7.4			6.3		4.7
46.0				5.7			7.9	4.1				6.8			5.7		4.6
48.0				5.1				3.7				6.2			5.2		4.1
50.0								3.3							4.7		3.7
θ (°)	5~53	5~49	5~39	5~32	5~49	5~50	5~48	5~26	5~52	5~43	5~44	5~48	5~43	5~41	5~44	5~44	5~30
標準フック	25t				25t				25t				25t				
フック質量	870kg				870kg				870kg				870kg				
標準巻掛本数	3				3				2				2				

注)カウンタウイト 78t、アウトリガ張出幅 8.5m
または、カウンタウイト 78t、アウトリガ張出幅 8.0m

●TLE性能

TRA+2.1m+38mラフingジブ

単位:t

ブーム長さ	35.3m				40.4m				45.4m			50.5m				
ブーム起伏角 作業半径 (m)	83°	75°	65°	55°	83°	75°	65°	83°	75°	65°	83°	75°	65°			
16.0	16.9															
18.0	16.9				13.4			9.0								
20.0	16.9				13.4			9.0			5.2					
22.0	16.9				13.4			9.0			5.2					
24.0	16.9				13.4			9.0			5.2					
26.0	16.9	16.9			13.4			9.0			5.2					
28.0	16.9	16.9			13.4	13.4		9.0			5.2					
30.0	16.9	16.9			13.4	13.4		9.0	9.0		5.2					
32.0	16.9	16.9			13.4	13.4		9.0	9.0		5.2	5.2				
34.0	16.7	16.9			13.4	13.4		9.0	9.0		5.2	5.2				
36.0	15.9	16.9			13.4	13.4		9.0	9.0		5.2	5.2				
38.0	15.2	15.9	11.8		13.4	13.4		9.0	9.0		5.2	5.2				
40.0		14.7	10.9			13.4	9.4	9.0	9.0		5.2	5.2				
42.0		13.7	10.0			13.0	8.6		9.0	7.1		5.2				
44.0		12.8	9.3			12.1	7.9		9.0	6.5		5.2				
46.0			8.6			11.3	7.3		9.0	5.9		5.2	4.7			
48.0			7.9	4.4			6.7		9.0	5.4		5.2	4.2			
50.0			7.3	4.0			6.1			4.9			3.8			
54.0				3.2			5.2			4.1			3.1			
58.0				2.5									2.4			
θ (°)	5~54	5~49	5~39	5~41	5~50	5~50	5~45	5~53	5~51	5~35	5~50	5~44	5~40			
標準フック	25t				25t				25t				25t			
フック質量	870kg				870kg				870kg				870kg			
標準巻掛本数	2				2				2				2			

注)カウンタウイト 78t、アウトリガ張出幅 8.5m
または、カウンタウイト 78t、アウトリガ張出幅 8.0m

●TLE性能

TRA+2.1m+47mラフingジブ

単位:t

ブーム長さ	35.3m			40.4m			45.4m			50.5m						
ブーム起伏角 作業半径 (m)	83°	75°	65°	83°	75°	65°	83°	75°	65°	83°	75°	65°				
18.0	11.2			9.0												
20.0	11.2			9.0			6.2									
22.0	11.2			9.0			6.2			3.6						
24.0	11.2			9.0			6.2			3.6						
26.0	11.2			9.0			6.2			3.6						
28.0	11.2	11.2		9.0			6.2			3.6						
30.0	11.2	11.2		9.0	9.0		6.2			3.6						
32.0	11.2	11.2		9.0	9.0		6.2	6.2		3.6						
34.0	11.2	11.2		9.0	9.0		6.2	6.2		3.6	3.6					
36.0	11.2	11.2		9.0	9.0		6.2	6.2		3.6	3.6					
38.0	11.2	11.2		9.0	9.0		6.2	6.2		3.6	3.6					
40.0	11.2	11.2		9.0	9.0		6.2	6.2		3.6	3.6					
42.0	11.0	11.2	9.1	9.0	9.0		6.2	6.2		3.6	3.6					
44.0	10.4	11.2	8.3	9.0	9.0		6.2	6.2		3.6	3.6					
46.0	10.0	11.2	7.7	9.0	9.0	6.3	6.2	6.2		3.6	3.6					
48.0		10.7	7.0	9.0	9.0	5.7	6.2	6.2	4.4	3.6	3.6					
50.0		10.0	6.5		9.0	5.2		6.2	3.9		3.6	2.8				
54.0		8.8	5.5		8.1	4.3		6.2	3.2		3.6	2.1				
58.0			4.6			3.6			2.5		3.6					
62.0						2.9			1.9							
θ (°)	5~54	5~55	5~39	5~57	5~49	5~43	5~54	5~45	5~36	5~51	5~51	5~15				
標準フック	25t				25t				25t				25t			
フック質量	870kg				870kg				870kg				870kg			
標準巻掛本数	2				2				2				2			

注)カウンタウイト 78t、アウトリガ張出幅 8.5m
または、カウンタウイト 78t、アウトリガ張出幅 8.0m

●TLF性能

TRA+2. 1m+20mラフィングジブ

単位:t

ブーム長さ	35.3m				40.4m			45.4m			50.5m			55.6m		
ブーム起伏角 作業半径(m)	83°	75°	65°	55°	83°	75°	65°	83°	75°	65°	83°	75°	65°	83°	75°	
11.0	34.6															
12.0	34.6															
14.0	34.6				29.2			18.8								
16.0	34.6				29.2			18.8			11.9				7.5	
18.0	34.6				29.2			18.8			11.9				7.5	
20.0	34.6	31.6			29.2			18.8			11.9				7.5	
22.0	32.7	27.7			29.2	26.2		18.8			11.9				7.5	
24.0		24.6				23.3			18.8		11.9				7.5	
26.0		22.0				20.8			18.8			11.9				
28.0		19.9	14.7			18.8			17.8			11.9			7.5	
30.0			13.3						16.1			11.9			7.5	
32.0			12.1					10.4				11.9			7.5	
34.0			11.0					9.4			7.9					
36.0				5.6				8.5			7.1			5.7		
38.0				5.0							6.4			5.1		
40.0				4.4										4.6		
θ(°)	5~51	5~50	5~40	5~34	5~46	5~39	5~36	5~41	5~41	5~33	5~45	5~42	5~29	5~39	5~32	
標準フック	80t				80t			25t								
フック質量	1270kg				1270kg			870kg								
標準巻掛本数	4				3			3								

注)カウンタウエイト 78t、アウトリガ張出幅 6.8m
 または、カウンタウエイト 58t、アウトリガ張出幅 8.5m
 または、カウンタウエイト 58t、アウトリガ張出幅 8.0m

●TLF性能

TRA+2. 1m+29mラフィングジブ

単位:t

ブーム長さ	35.3m				40.4m			45.4m			50.5m			55.6m		
ブーム起伏角 作業半径(m)	83°	75°	65°	55°	83°	75°	65°	83°	75°	65°	83°	75°	65°	83°	75°	
14.0	24.7															
16.0	24.7				20.3			13.4								
18.0	24.7				20.3			13.4			7.7				4.7	
20.0	24.7				20.3			13.4			7.7				4.7	
22.0	24.7	24.7			20.3			13.4			7.7				4.7	
24.0	24.7	24.0			20.3	20.3		13.4			7.7				4.7	
26.0	24.7	21.4			20.3	20.1		13.4	13.4		7.7				4.7	
28.0	23.3	19.4			20.3	18.1		13.4	13.4		7.7	7.7			4.7	
30.0	21.1	17.6			20.3	16.5		13.4	13.4		7.7	7.7			4.7	
32.0		16.0	11.2			15.0		13.4	13.4		7.7	7.7			4.7	
34.0		14.7	10.1			13.7			12.9		7.7				4.7	
36.0		13.5	9.2			12.6	7.6		11.8		7.7				4.7	
38.0			8.4			11.6	6.8		10.9	5.4	7.7				4.7	
40.0			7.6				6.2			4.8	7.7				4.7	
42.0			6.9	3.0			5.6			4.3			3.1		4.7	
44.0				2.6			5.0			3.9				2.7		
46.0				2.3			4.5			3.4				2.3		
48.0										3.0				2.0		
θ(°)	5~53	5~49	5~39	5~23	5~49	5~50	5~48	5~52	5~43	5~44	5~48	5~43	5~32	5~44	5~44	
標準フック	25t				25t			25t								
フック質量	870kg				870kg			870kg								
標準巻掛本数	3				2			2								

注)カウンタウエイト 78t、アウトリガ張出幅 6.8m
 または、カウンタウエイト 58t、アウトリガ張出幅 8.5m
 または、カウンタウエイト 58t、アウトリガ張出幅 8.0m

10. 作業半径 - 揚程図

[ESPブーム1]

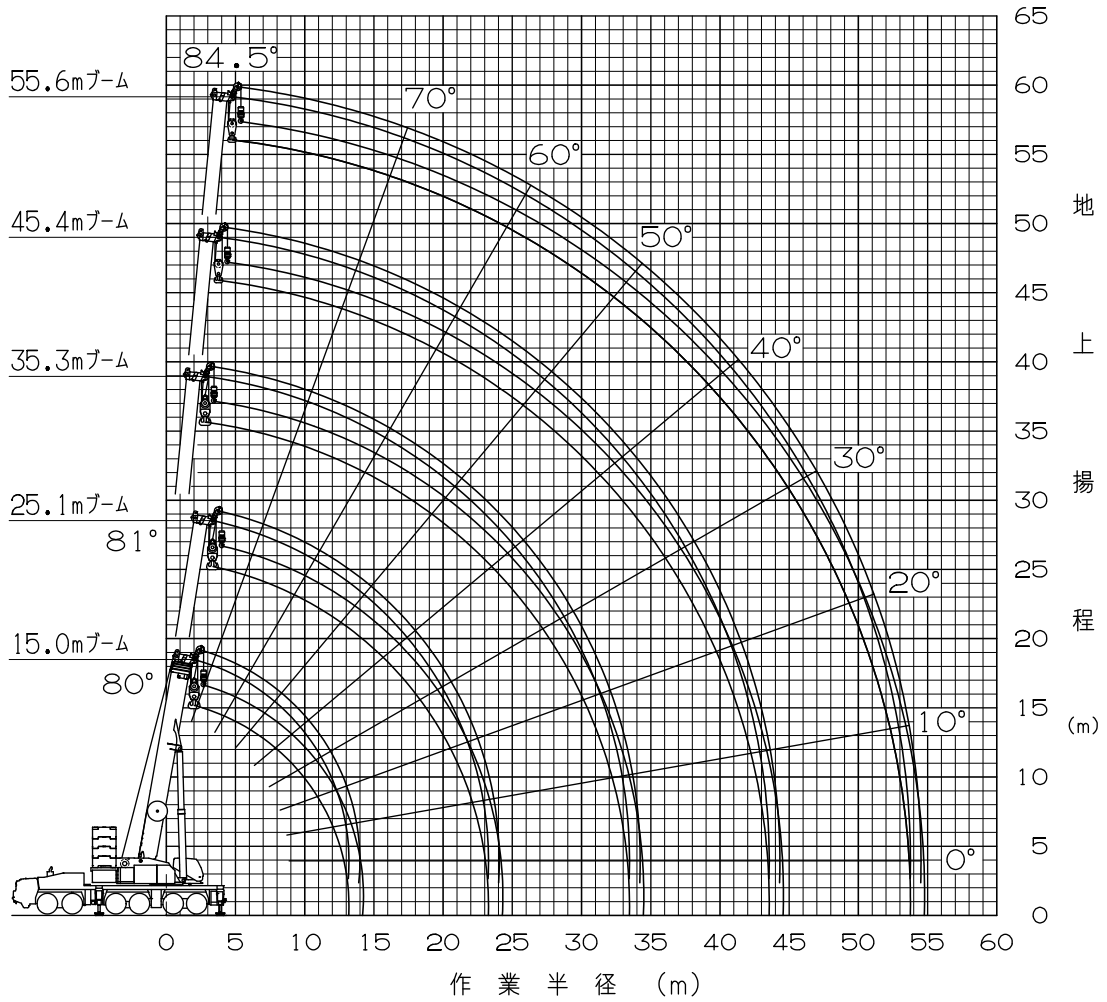

注意

- ◆ 上図はブームのたわみを含んでいません。
- ◆ D, E, G, H性能の最大作業半径を図示しています。

[ESPブーム2]

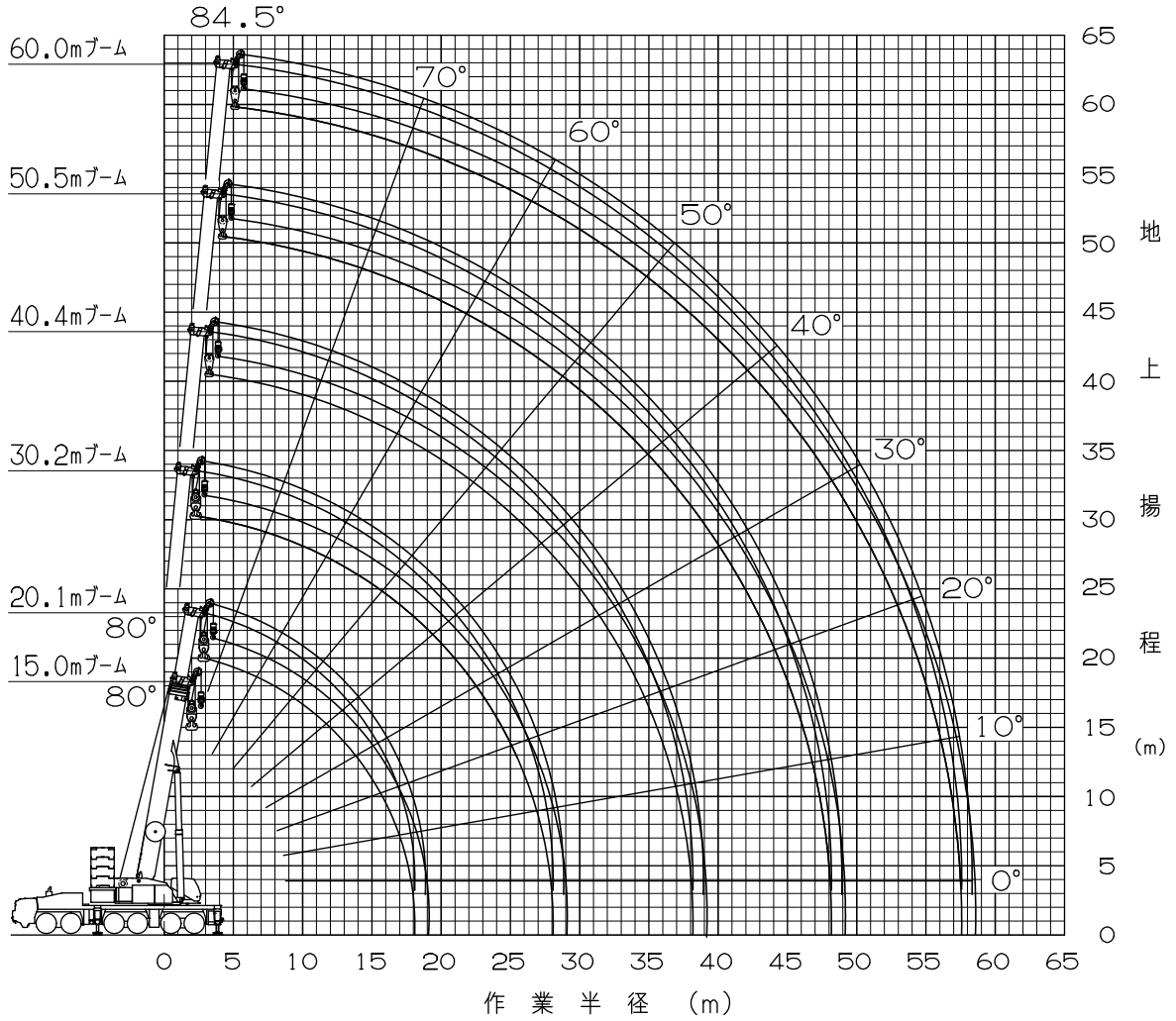

注意

- ◆ 上図はブームのたわみを含んでいません。
- ◆ D, E, G, H性能の最大作業半径を図示しています。

[40.4mブーム+1.6m+フルオートラフィングジブ]

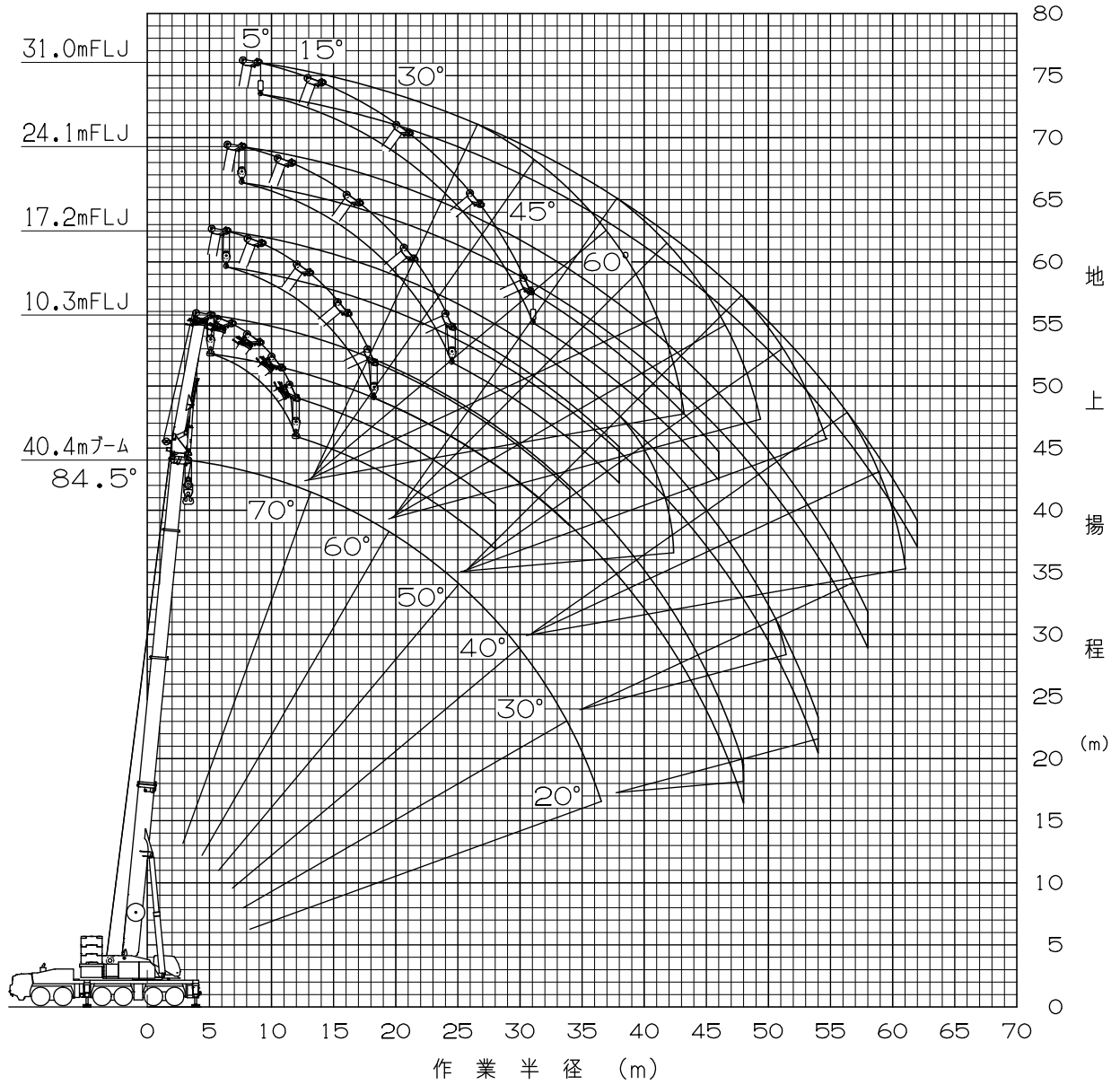

注意

- ◆ 上図はブームおよびジブのたわみを含んでいません。
- ◆ FC性能の最大作業半径を図示しています。

[45.4mブーム+1.6m+フルオートラフィングジブ]

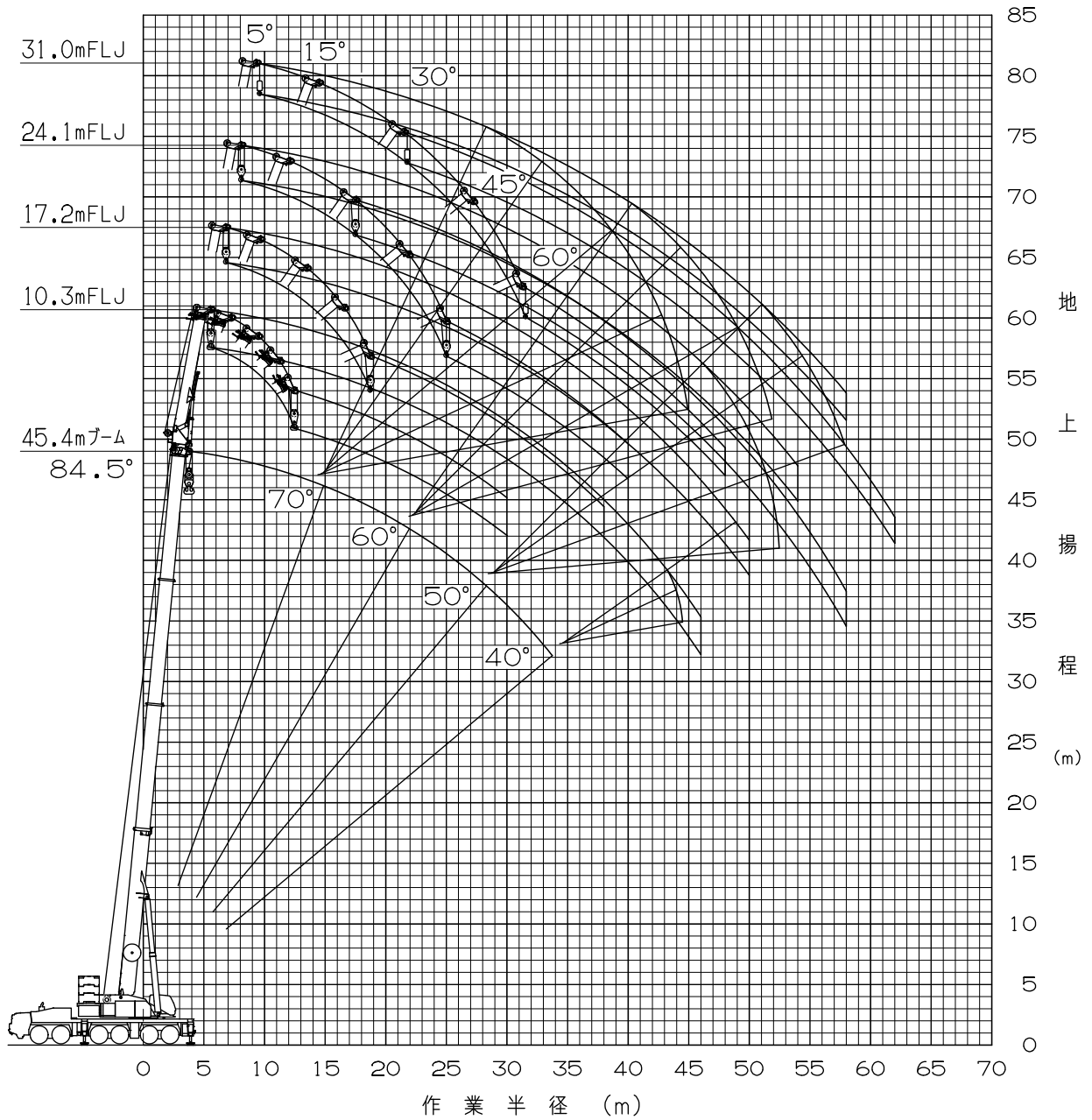

注意

- ◆ 上図はブームおよびジブのたわみを含んでいません。
- ◆ FC性能の最大作業半径を図示しています。

[50.5mブーム+1.6m+フルオートラフィングジブ]

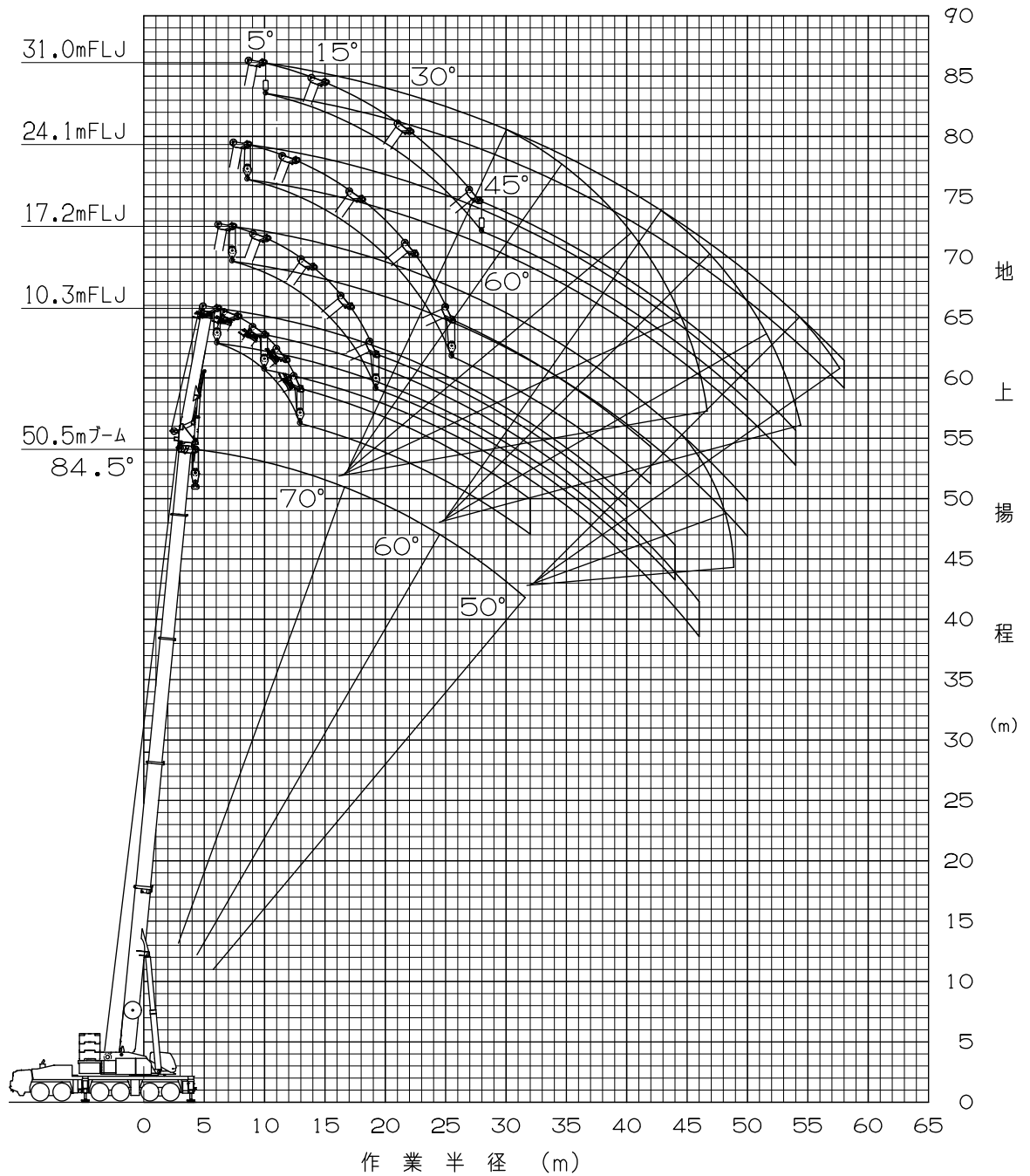

注意

- ◆ 上図はブームおよびジブのたわみを含んでいません。
- ◆ FC性能の最大作業半径を図示しています。

[55.6mブーム+1.6m+フルオートラフィングジブ]

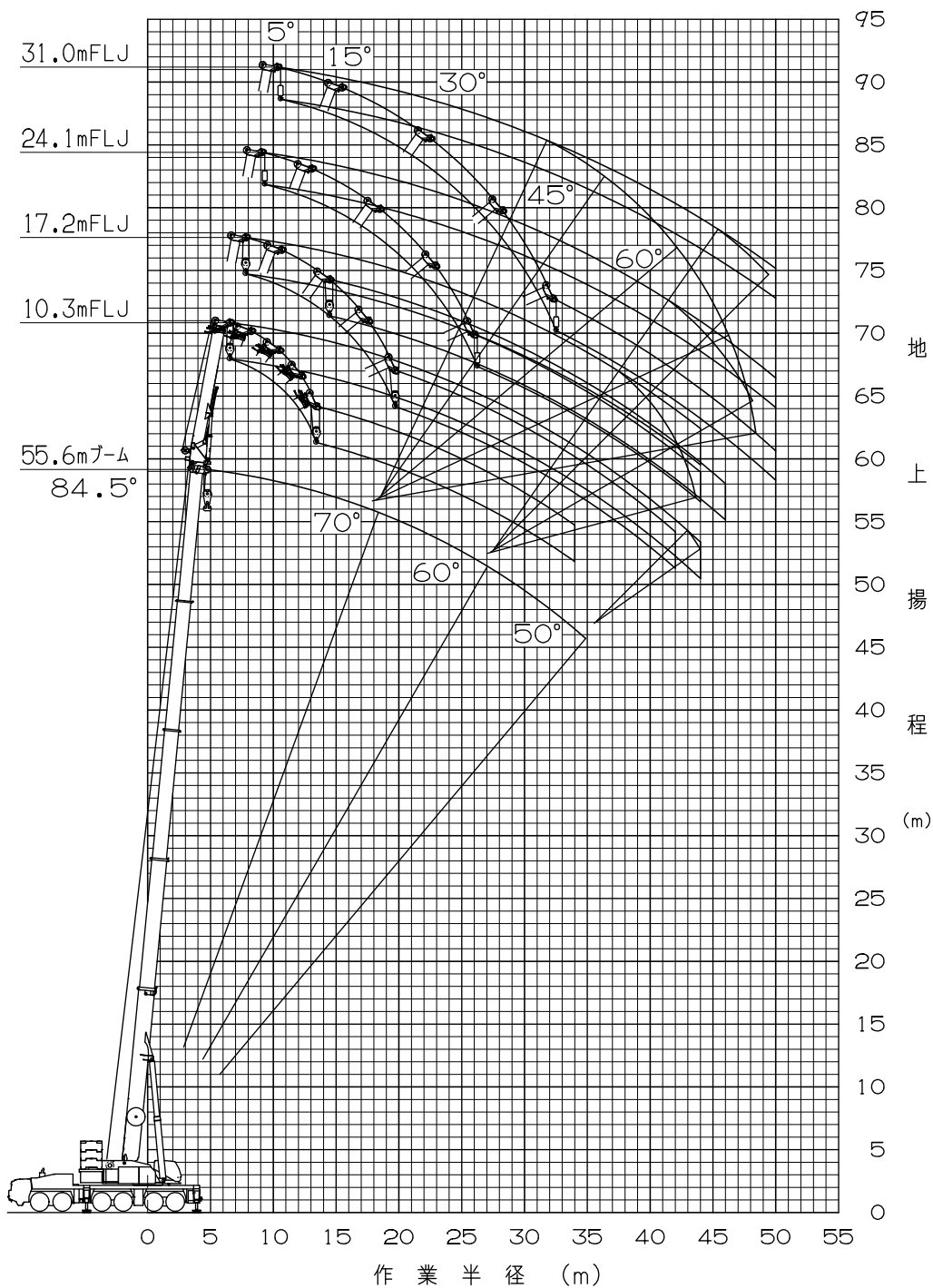

- 注意
- ◆ 上図はブームおよびジブのたわみを含んでいません。
 - ◆ FC性能の最大作業半径を図示しています。

[60.0mブーム+1.6m+フルオートラフィングジブ]

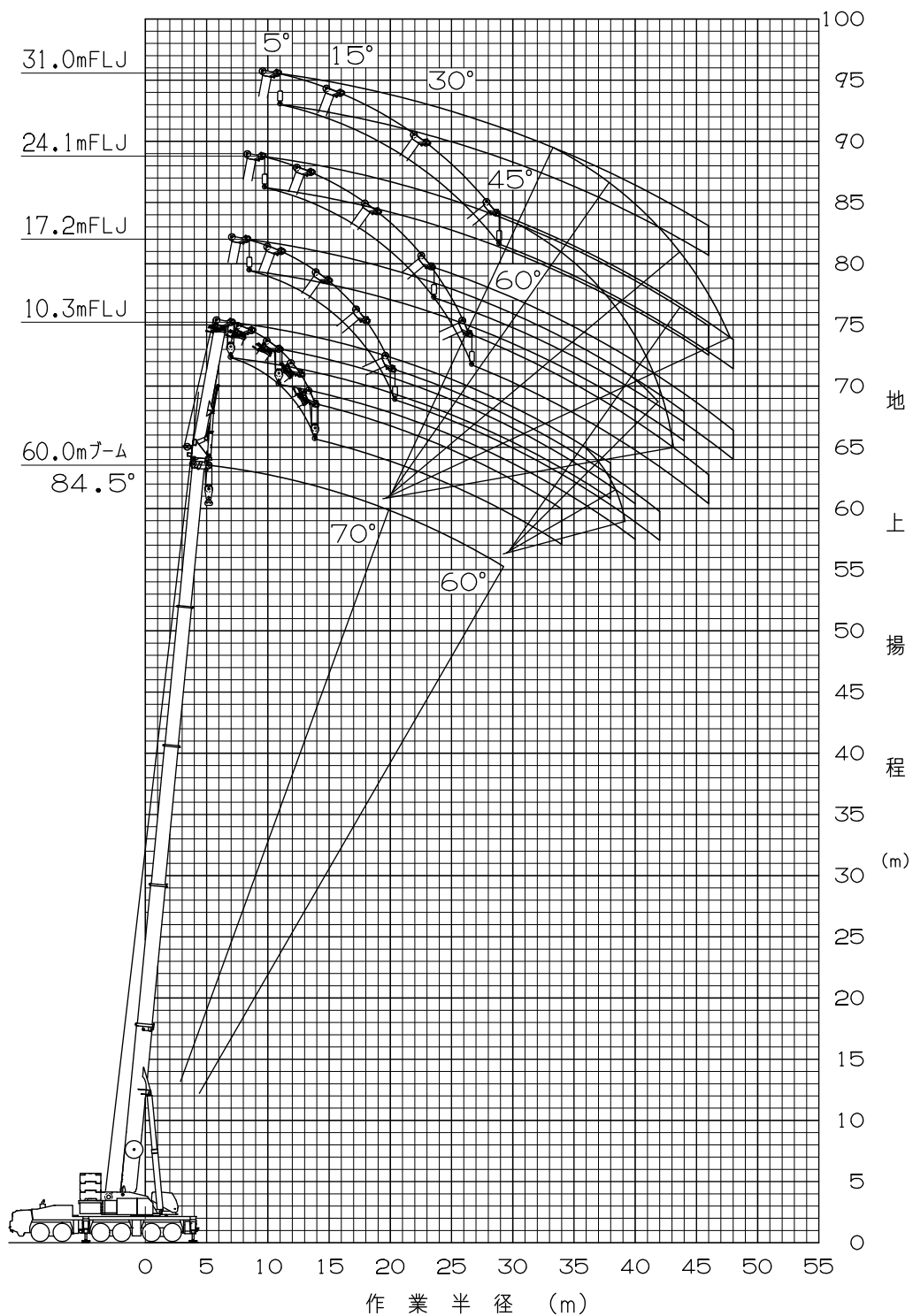

- 注意**
- ◆ 上図はブームおよびジブのたわみを含んでいません。
 - ◆ FC性能の最大作業半径を図示しています。

[2.1m+20mラフィングジブ]

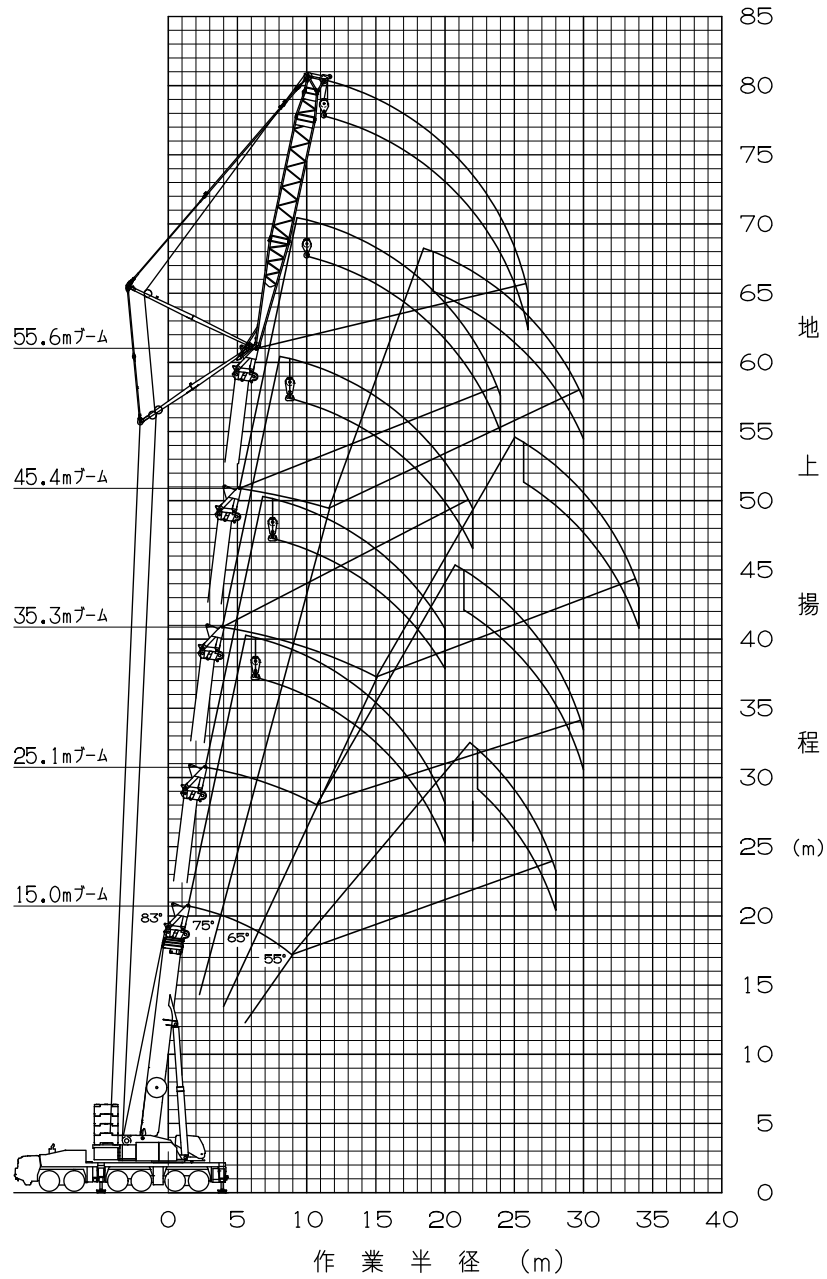

注意

- ◆ 上図はブームおよびジブのたわみを含んでいません。
- ◆ L/B性能の最大作業半径を図示しています。
- ◆ 20.1m、30.2m、40.4m、50.5mブームの揚程図は図示していません。

[2.1m+29mラフィングジブ]

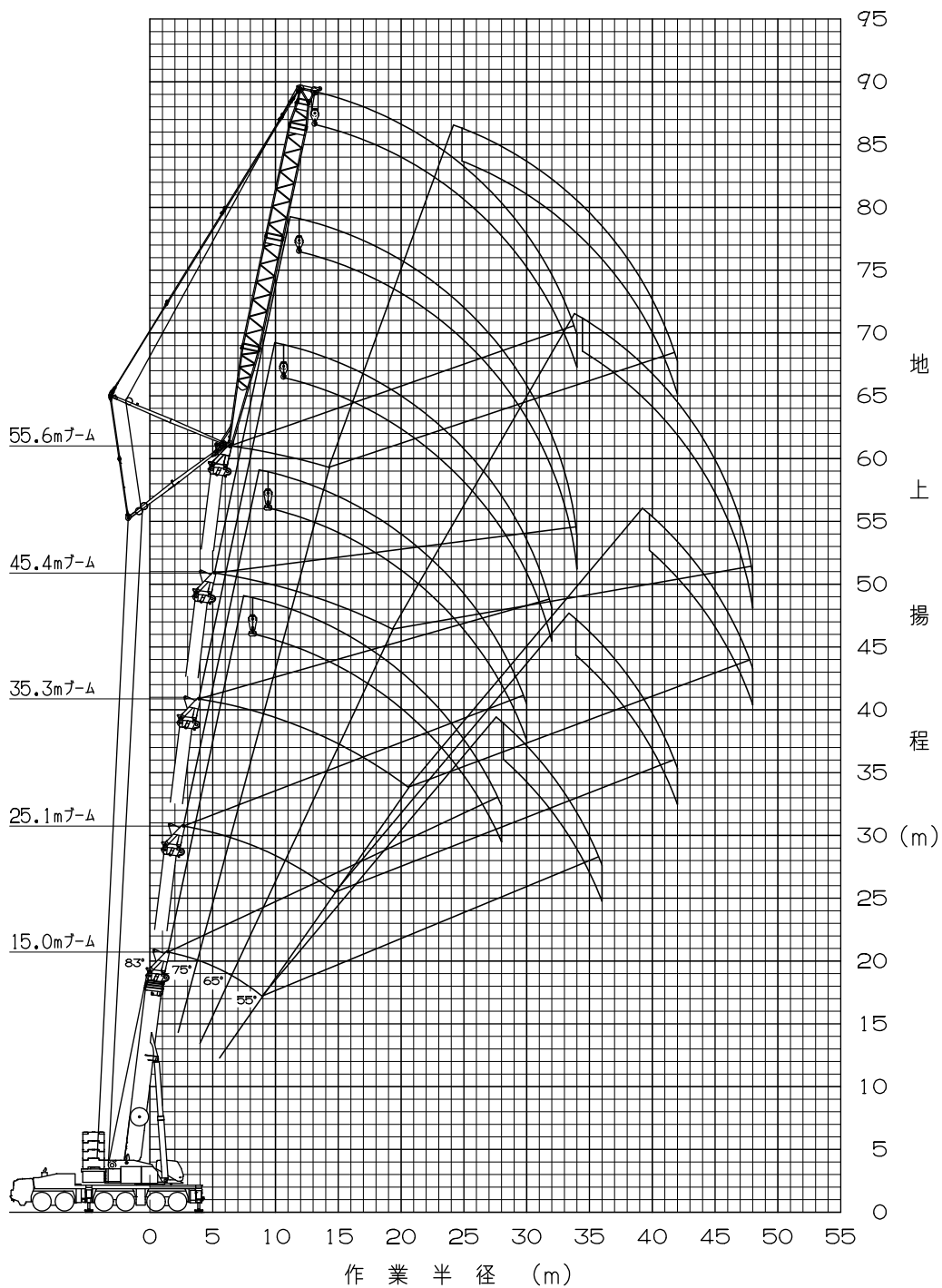

- 注意**
- ◆ 上図はブームおよびジブのたわみを含んでいません。
 - ◆ LA性能の最大作業半径を図示しています。
 - ◆ 20.1m、30.2m、40.4m、50.5mブームの揚程図は図示していません。

[2.1m+38mラフィングジブ]

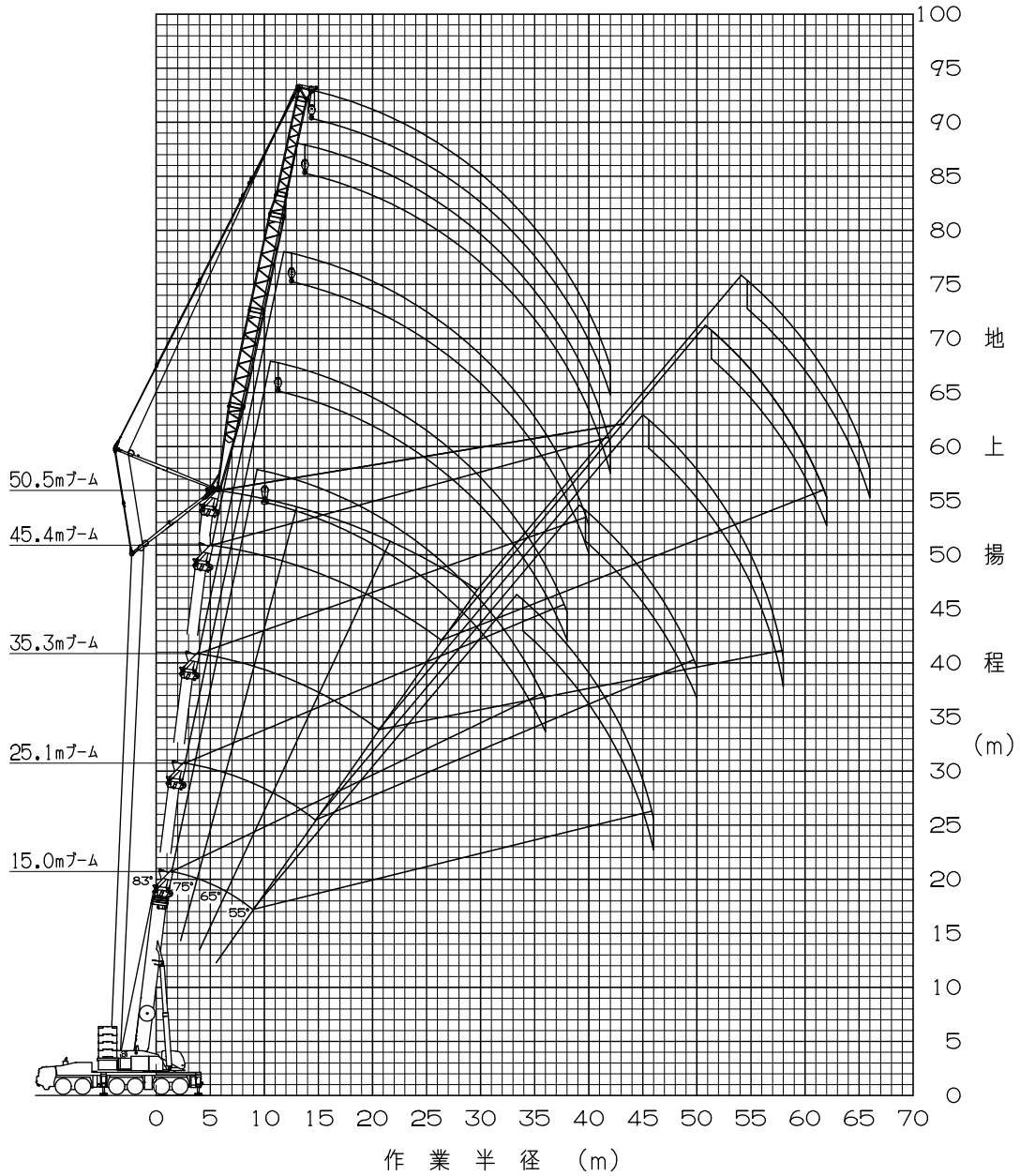

注意

- ◆ 上図はブームおよびジブのたわみを含んでいません。
- ◆ LA性能の最大作業半径を図示しています。
- ◆ 20.1m、30.2m、40.4mブームの揚程図は図示していません。

[2.1m+47mラフィングジブ]

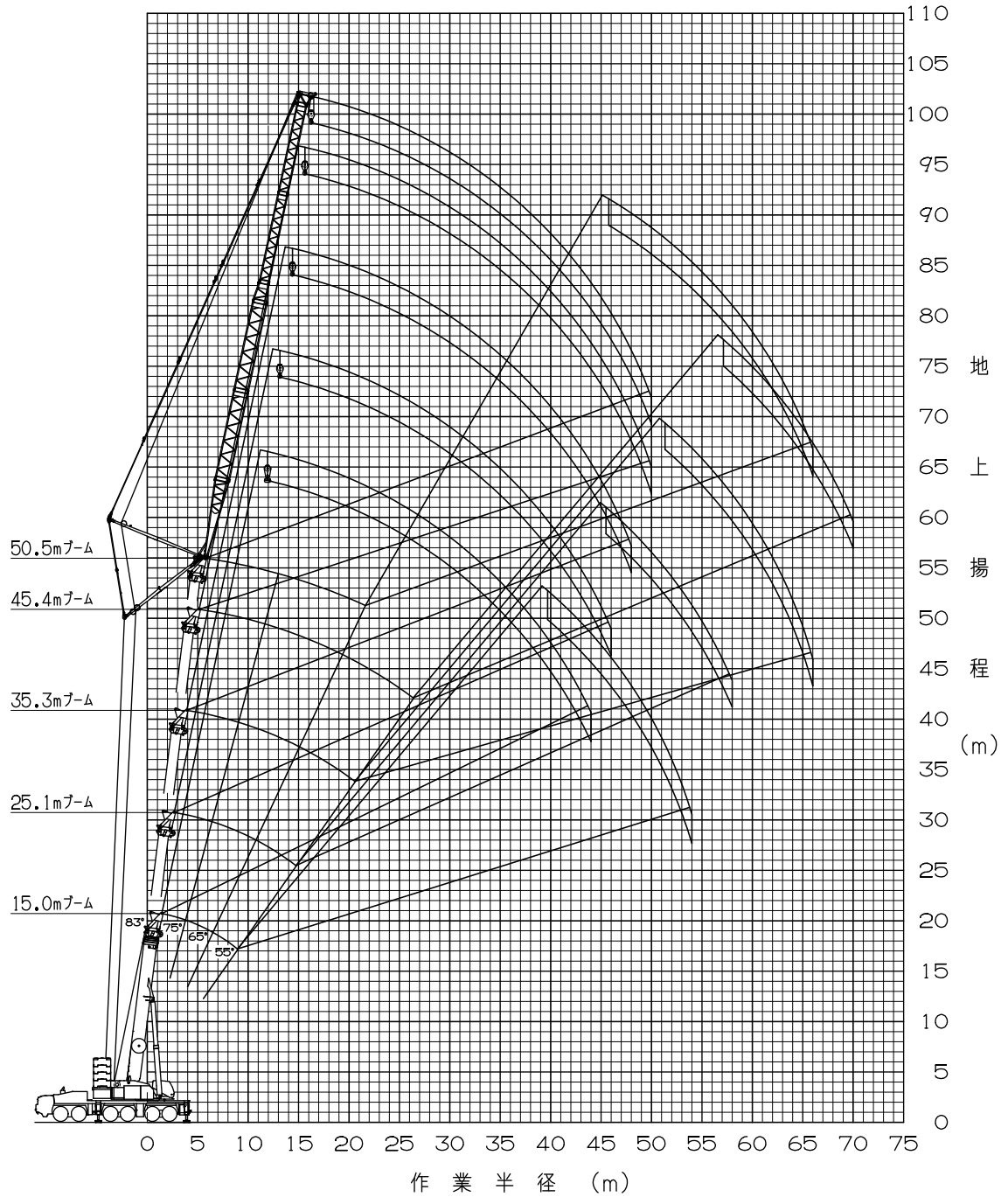

注意

- ◆ 上図はブームおよびジブのたわみを含んでいません。
- ◆ LA性能の最大作業半径を図示しています。
- ◆ 20.1m、30.2m、40.4mブームの揚程図は図示していません。

[2.1m + 47m ラフィングジブ + 9m エクステンションジブ]

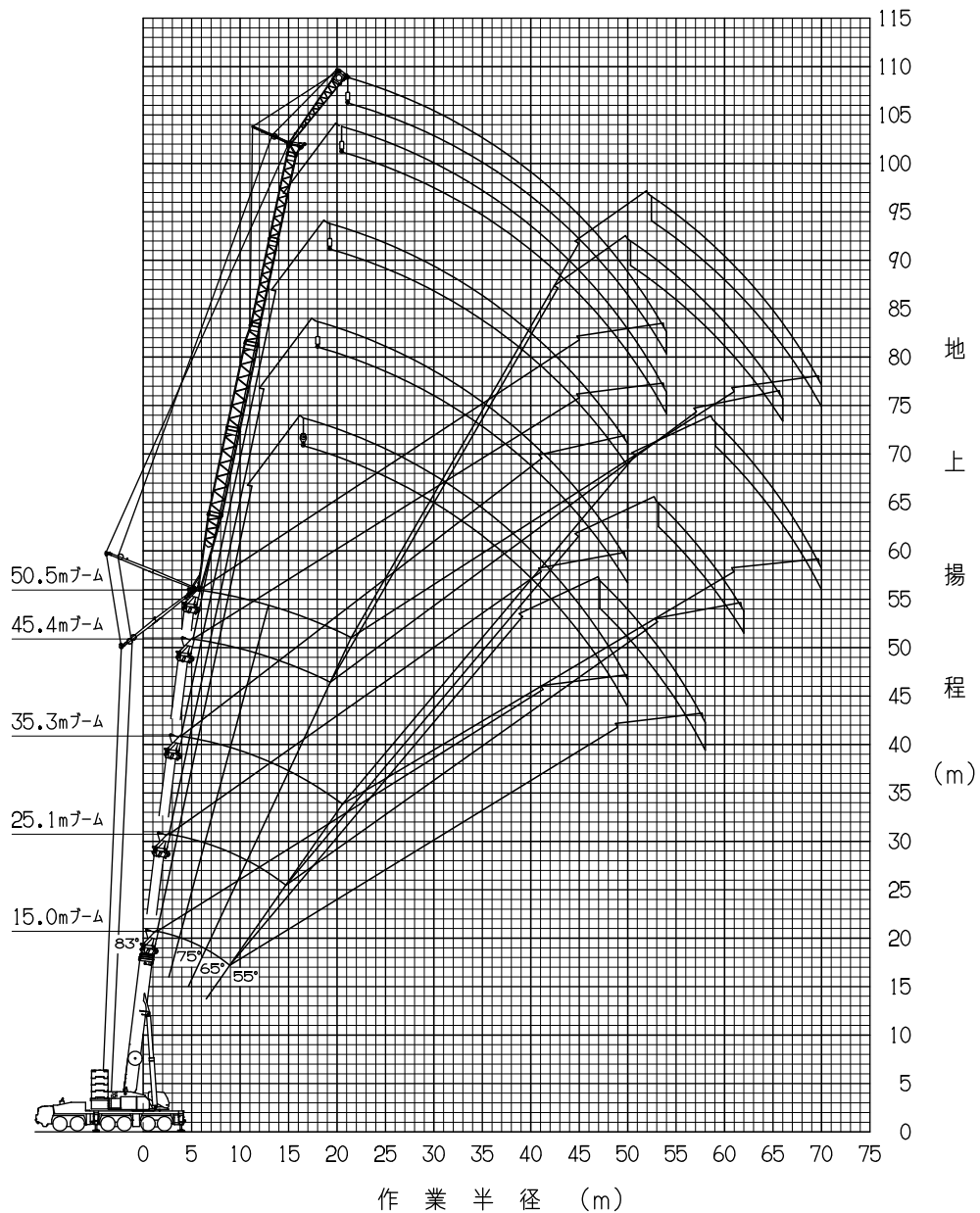

注意

- ◆ 上図はブームおよびジブのたわみを含んでいません。
- ◆ LA性能の最大作業半径を図示しています。
- ◆ 20.1m、30.2m、40.4mブームの揚程図は図示していません。

[2.1m+47mラフィングジブ+17mエクステンションジブ]

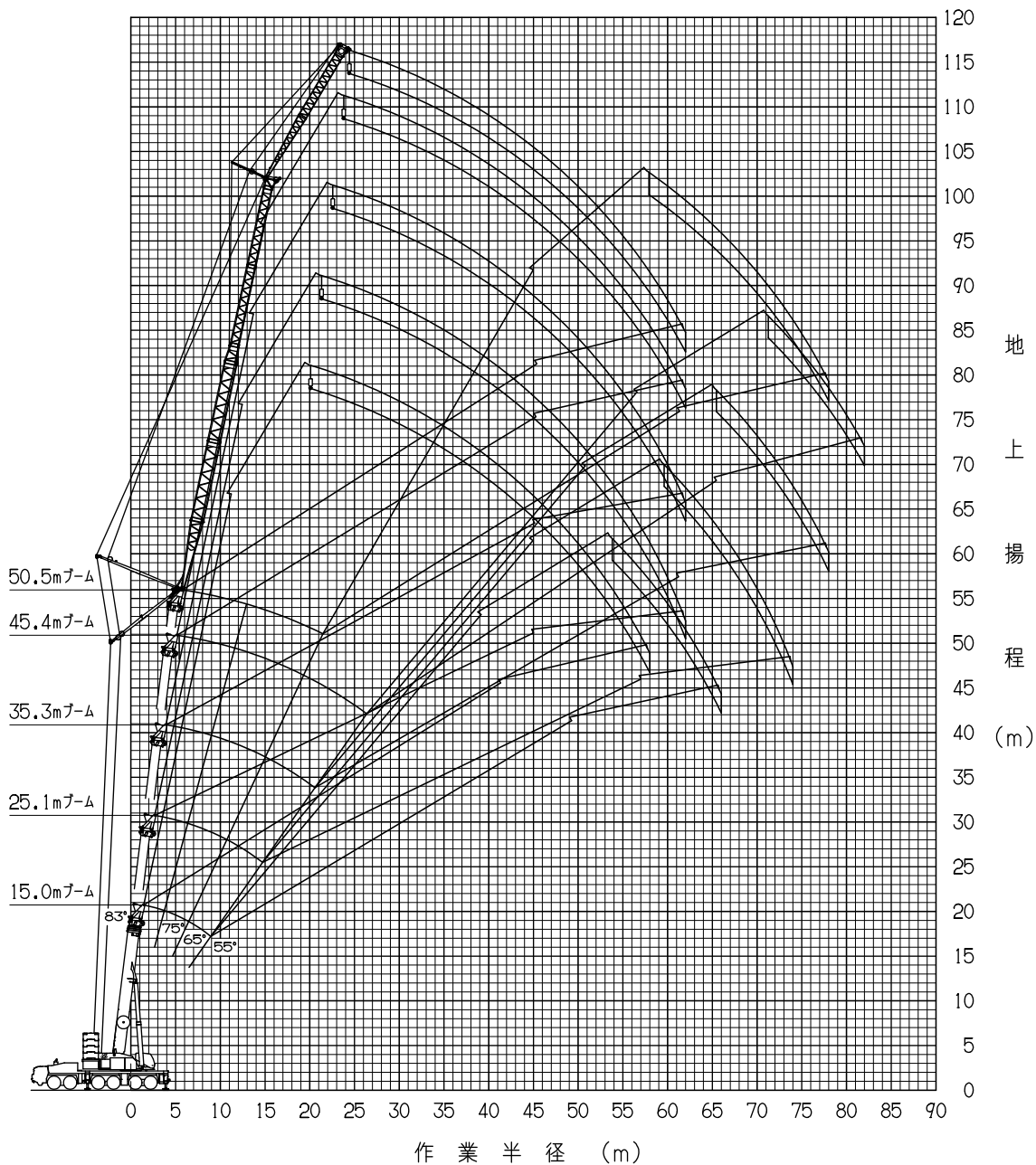

- 注意**
- ◆ 上図はブームおよびジブのたわみを含んでいません。
 - ◆ LA性能の最大作業半径を図示しています。
 - ◆ 20.1m、30.2m、40.4mブームの揚程図は図示していません。

[2.1m+47mラフィングジブ+25mエクステンションジブ]

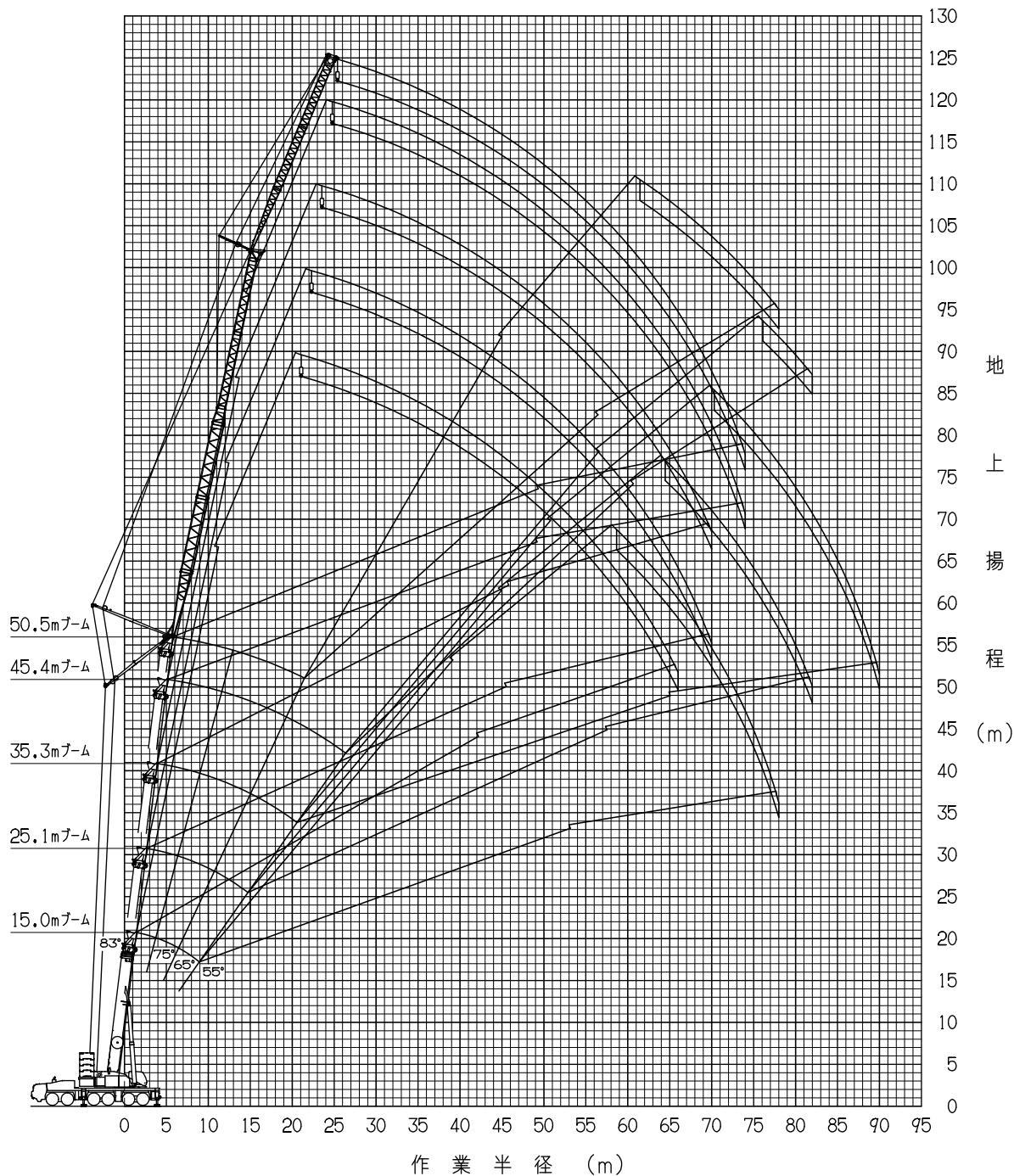

注意

- ◆ 上図はブームおよびジブのたわみを含んでいません。
- ◆ LA性能の最大作業半径を図示しています。
- ◆ 20.1m、30.2m、40.4mブームの揚程図は図示していません。

[TRA+ESPブーム]

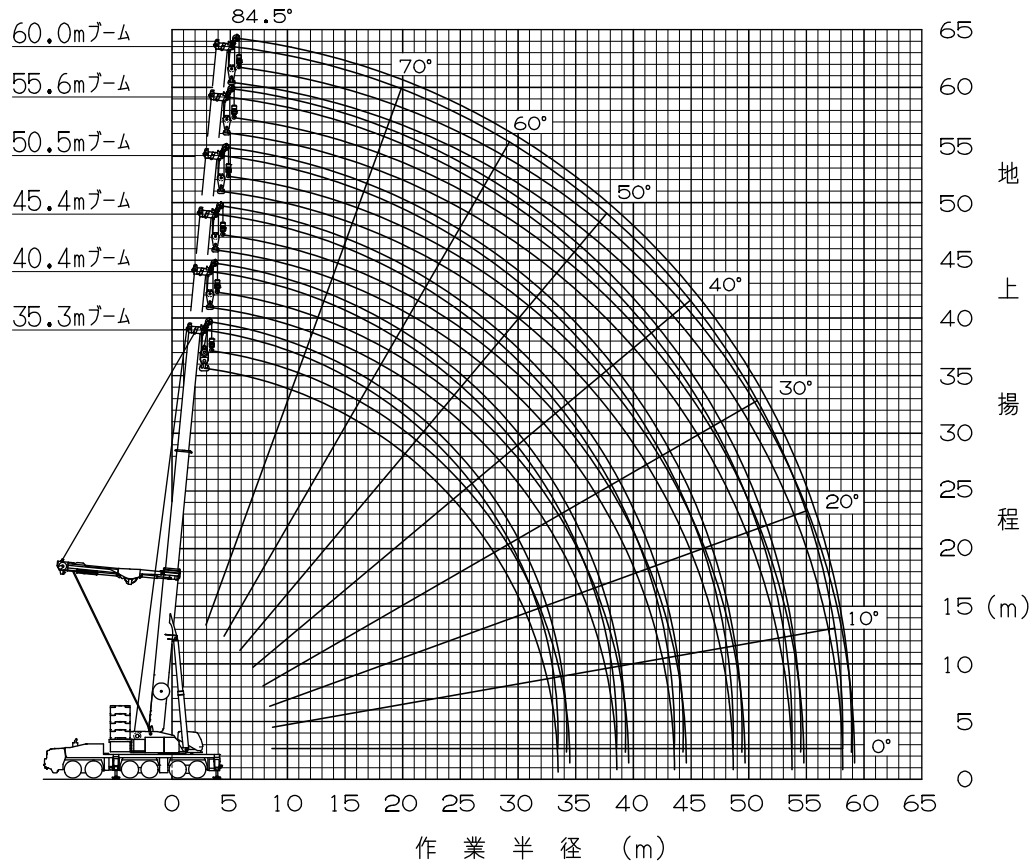

注意

- ◆ 上図はブームのたわみを含んでいません。
- ◆ TE性能の最大作業半径を図示しています。

[T R A + 40.4mブーム+1.6m+フルオートラフィングジブ]

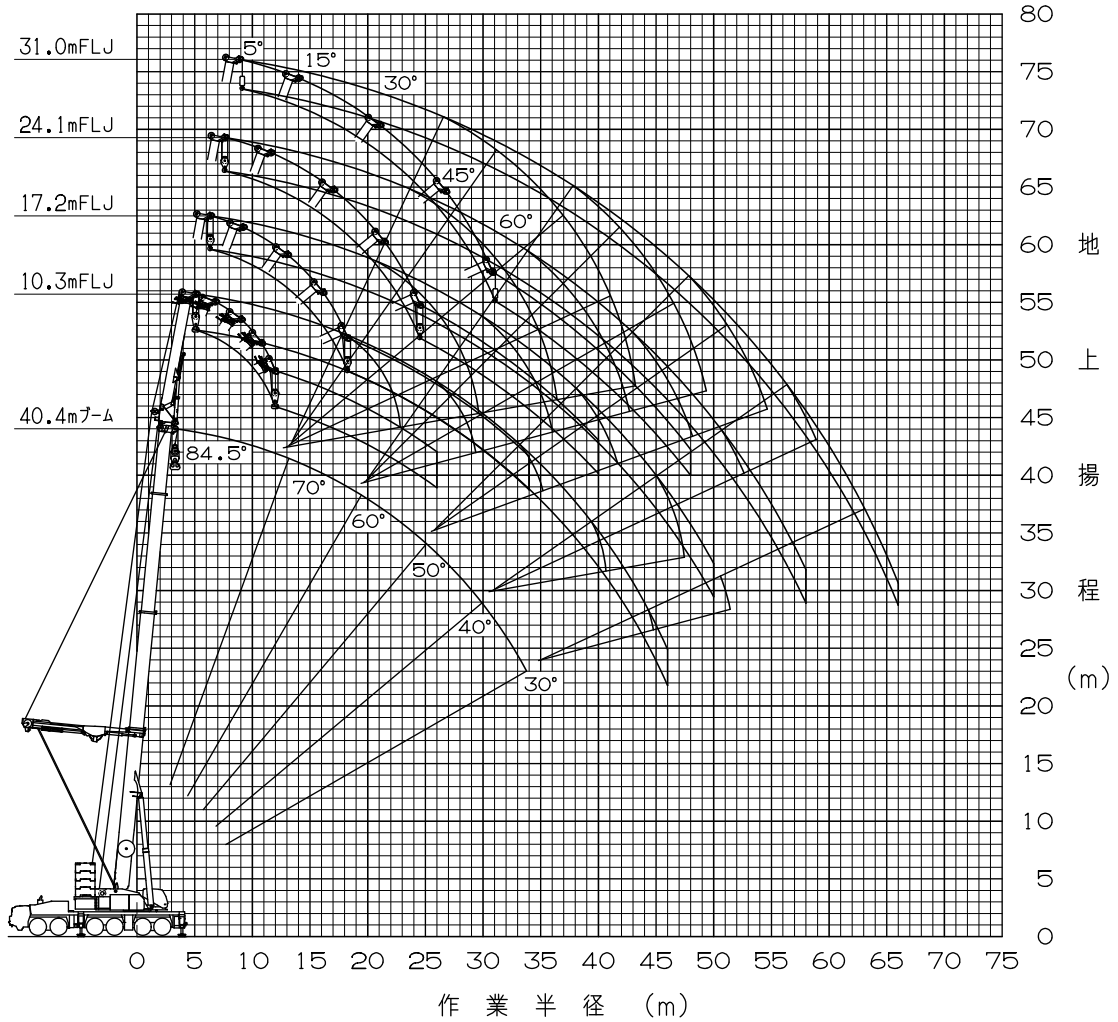

注意

- ◆ 上図はブームおよびジブのたわみを含んでいません。
- ◆ TFB性能の最大作業半径を図示しています。

[T R A + 45.4mブーム + 1.6m + フルオートラフィングジブ]

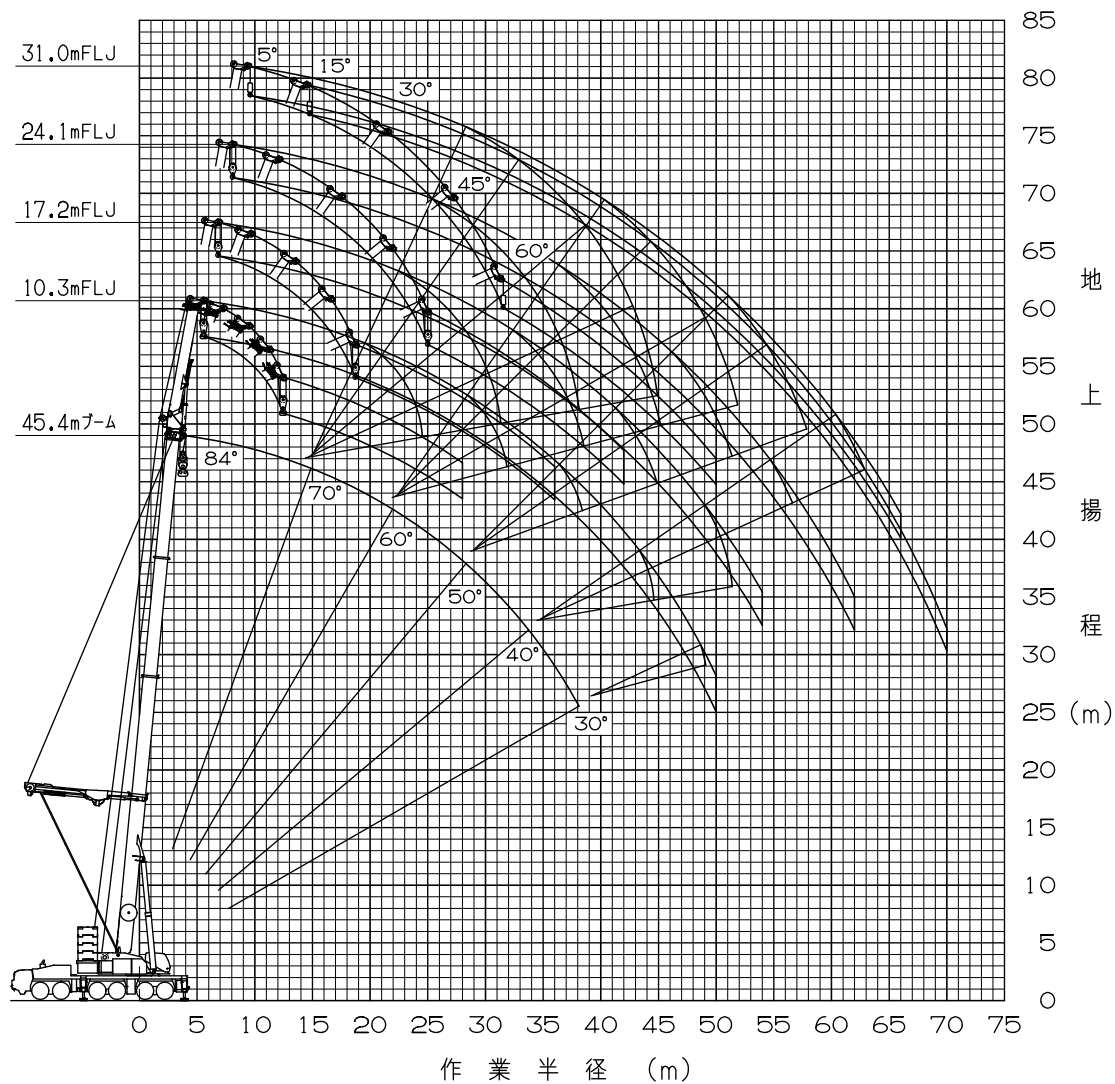

注意

- ◆ 上図はブームおよびジブのたわみを含んでいません。
- ◆ T F A 性能の最大作業半径を図示しています。

[T R A + 50.5mブーム + 1.6m + フルオートラフィングジブ]

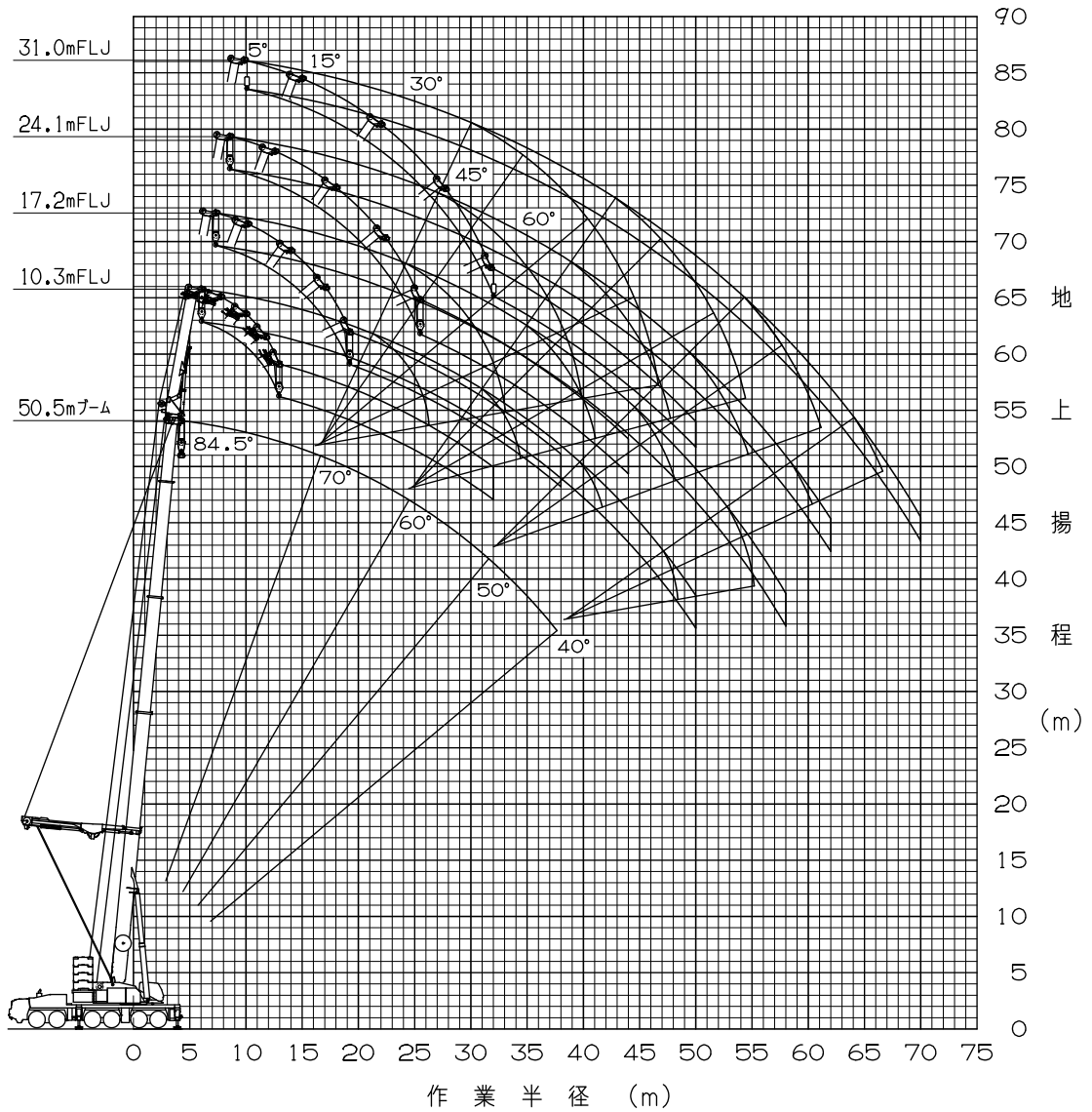

注意

- ◆ 上図はブームおよびジブのたわみを含んでいません。
- ◆ TFA性能の最大作業半径を図示しています。

[T R A + 55.6mブーム + 1.6m + フルオートラフィングジブ]

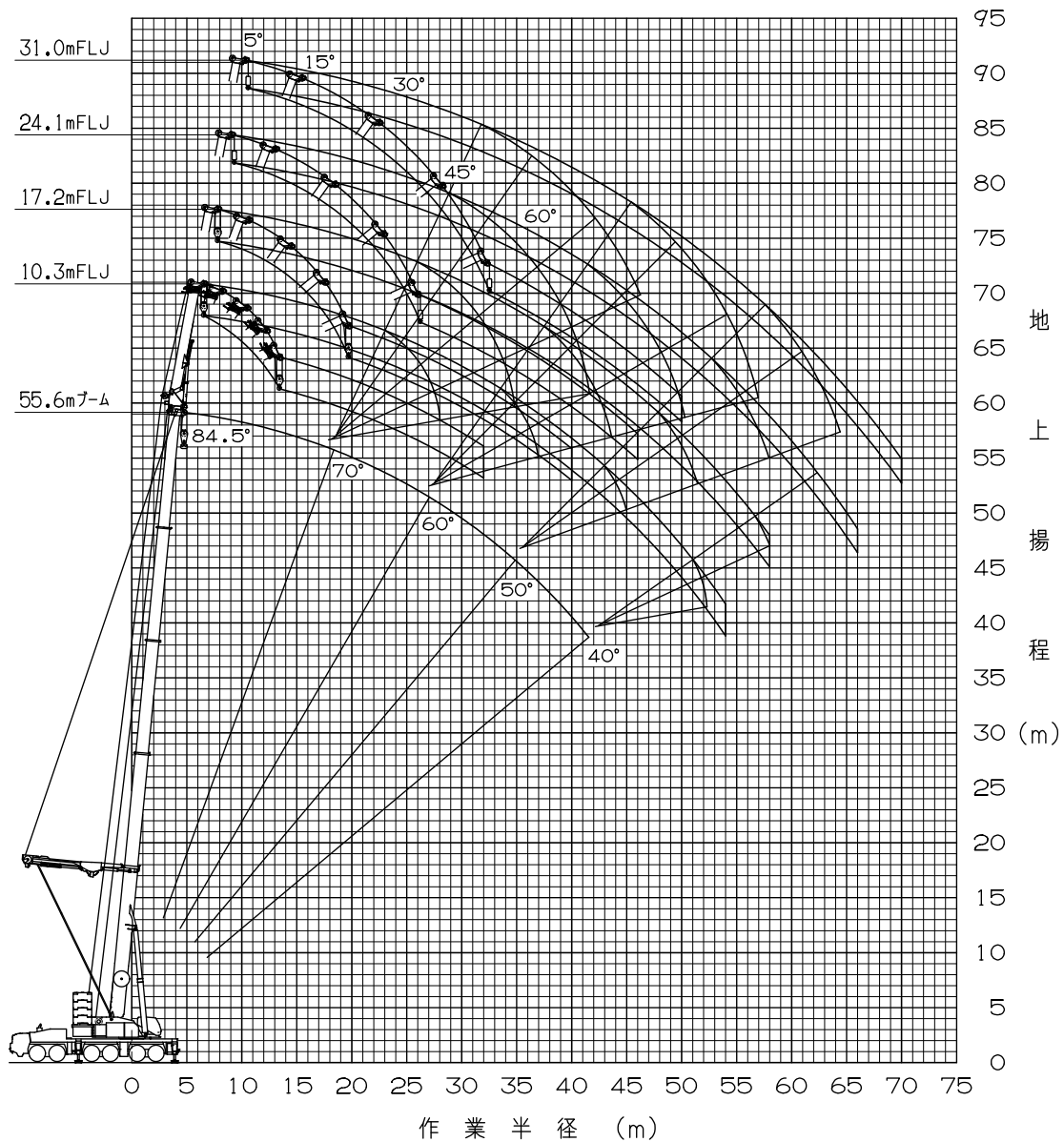

注意

- ◆ 上図はブームおよびジブのたわみを含んでいません。
- ◆ T F A 性能の最大作業半径を図示しています。

[T R A + 60.0mブーム + 1.6m + フルオートラフィングジブ]

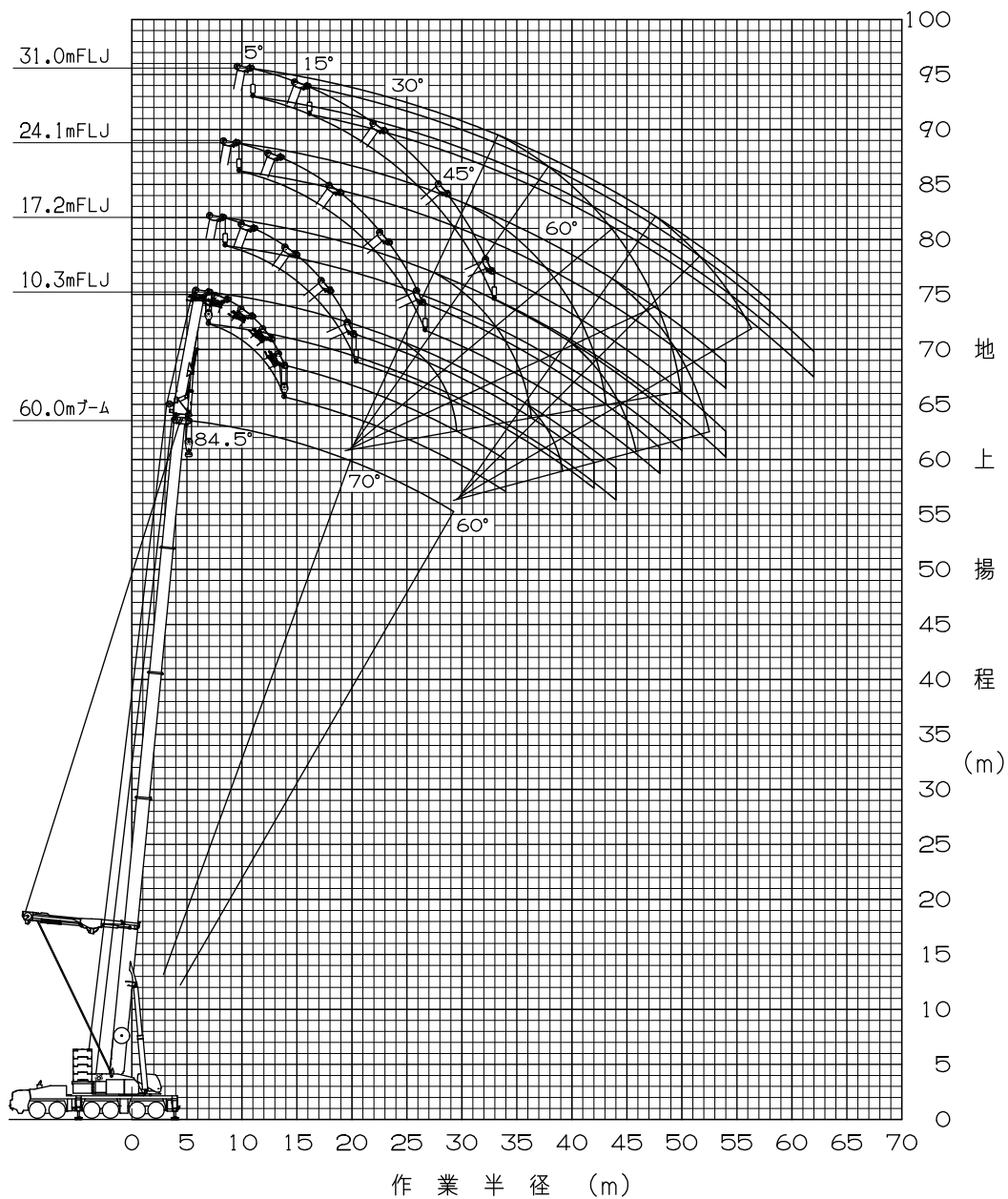

- 注意
- ◆ 上図はブームおよびジブのたわみを含んでいません。
 - ◆ TFA性能の最大作業半径を図示しています。

[TRA + ICA + 50.5mブーム + 1.6m + フルオートラフィングジブ]

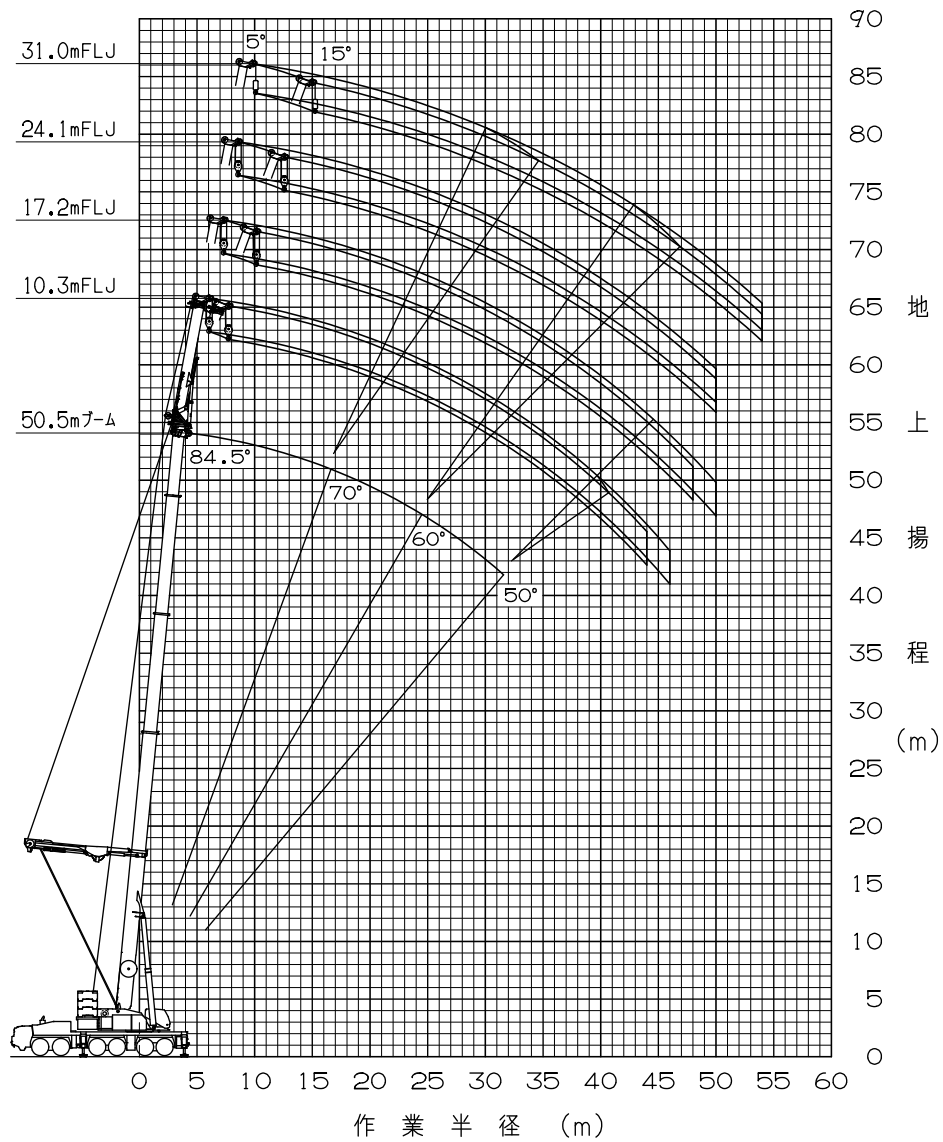

注意

- ◆ 上図はブームおよびジブのたわみを含んでいません。
- ◆ IFD性能の最大作業半径を図示しています。

[TRA + ICA + 55.6mブーム + 1.6m + フルオートラフィングジブ]

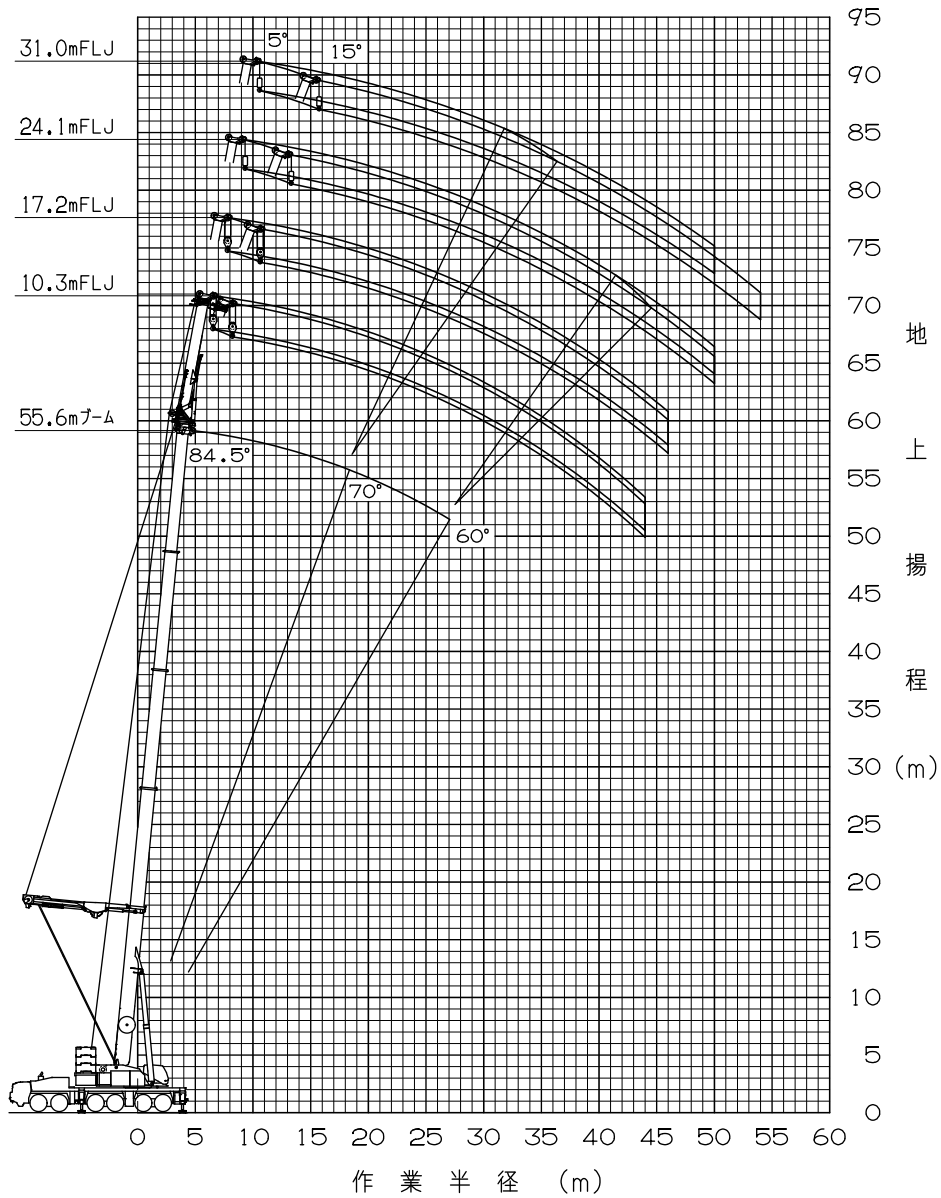

- 注意
- ◆ 上図はブームおよびジブのたわみを含んでいません。
 - ◆ IFD性能の最大作業半径を図示しています。

[T R A + I C A + 60.0m ブーム + 1.6m + フルオートラフィングジブ]

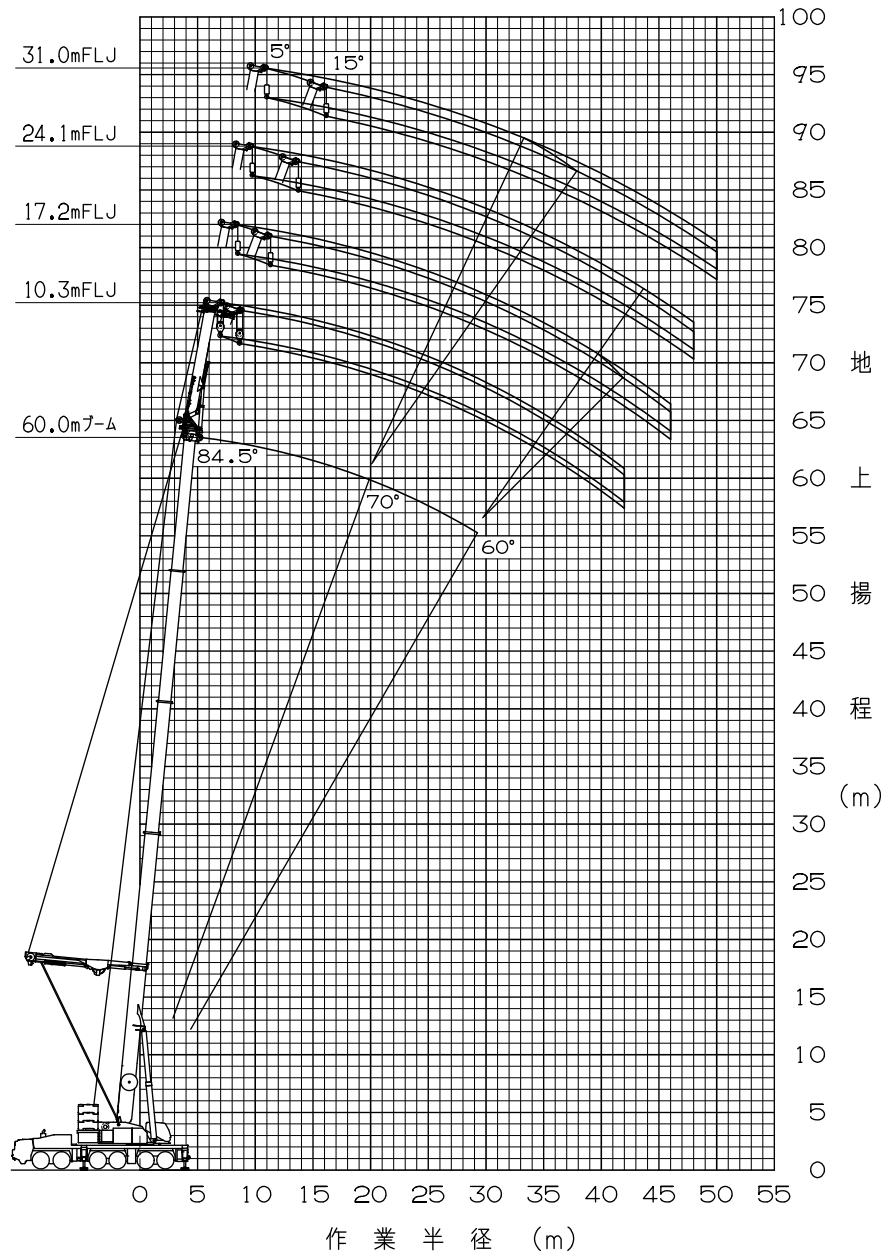

- 注意
- ◆ 上図はブームおよびジブのたわみを含んでいません。
 - ◆ I F D 性能の最大作業半径を図示しています。

[T R A + 2.1m + 20m ラフィングジブ]

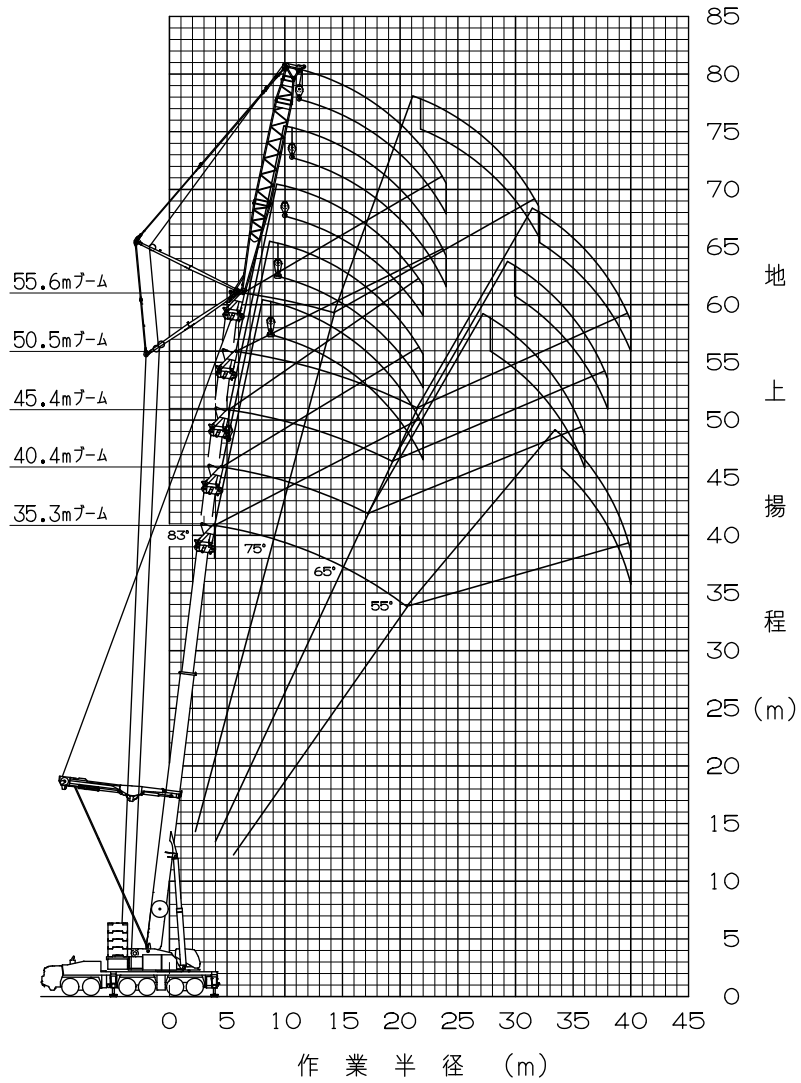

注意

- ◆ 上図はブームおよびジブのたわみを含んでいません。
- ◆ TLB性能の最大作業半径を図示しています。

[T R A + 2. 1 m + 29 m ラフィングジブ]

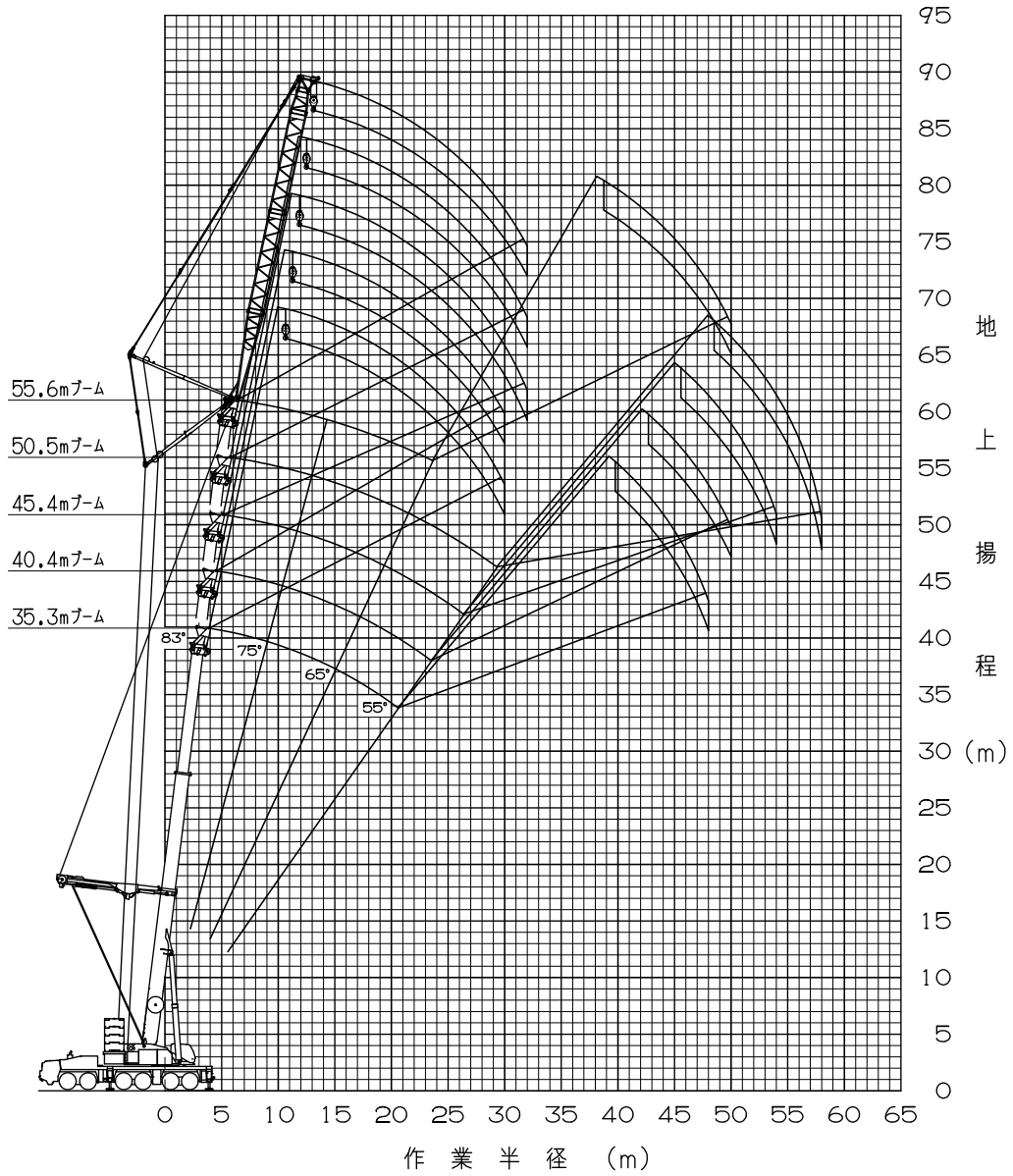

注意

- ◆ 上図はブームおよびジブのたわみを含んでいません。
- ◆ T L B性能の最大作業半径を図示しています。

[T R A + 2. 1 m + 3 8 m ラフィングジブ]

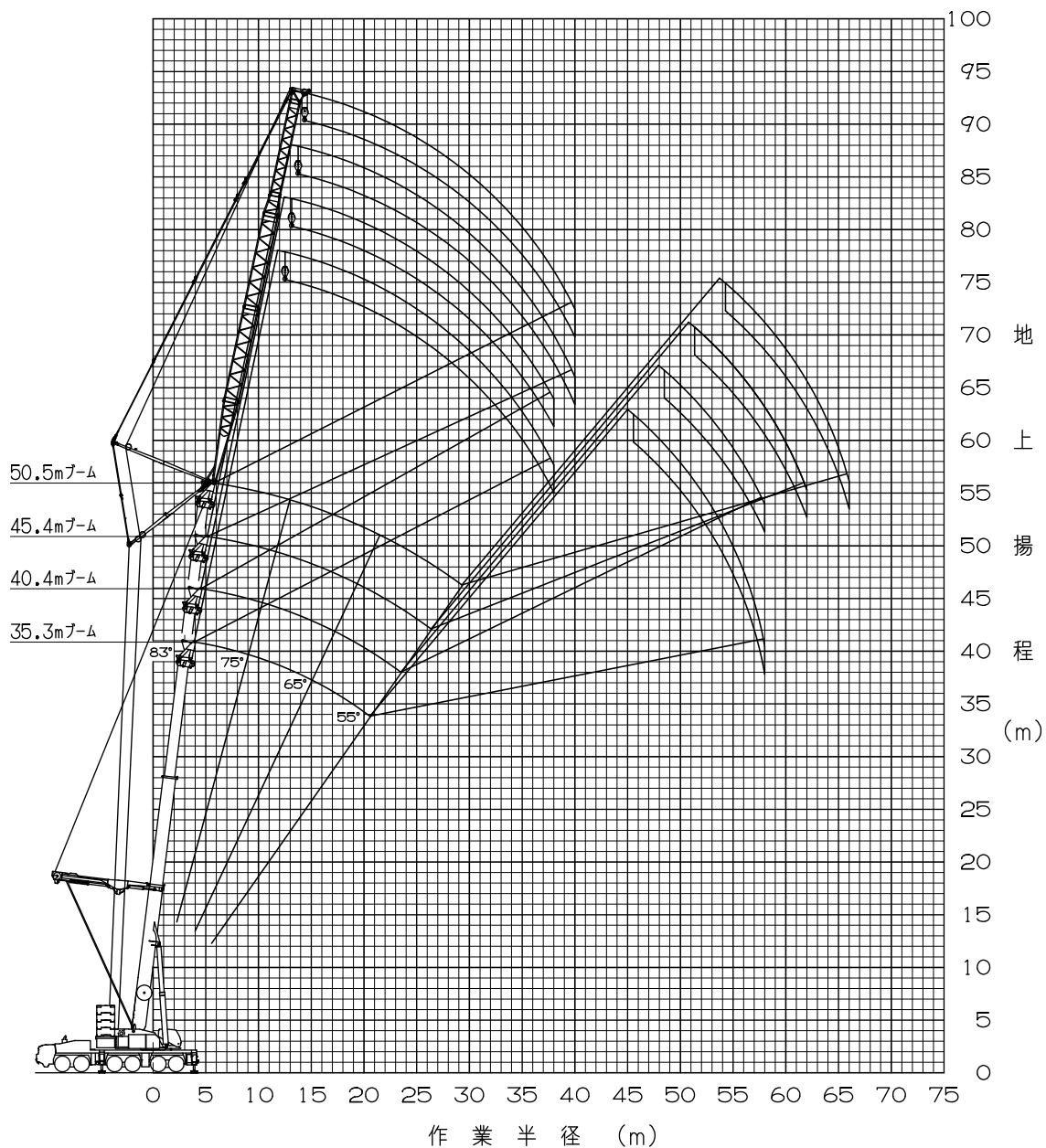

注意

- ◆ 上図はブームおよびジブのたわみを含んでいません。
- ◆ T L A性能の最大作業半径を図示しています。

[TRA+2.1m+47mラフィングジブ]

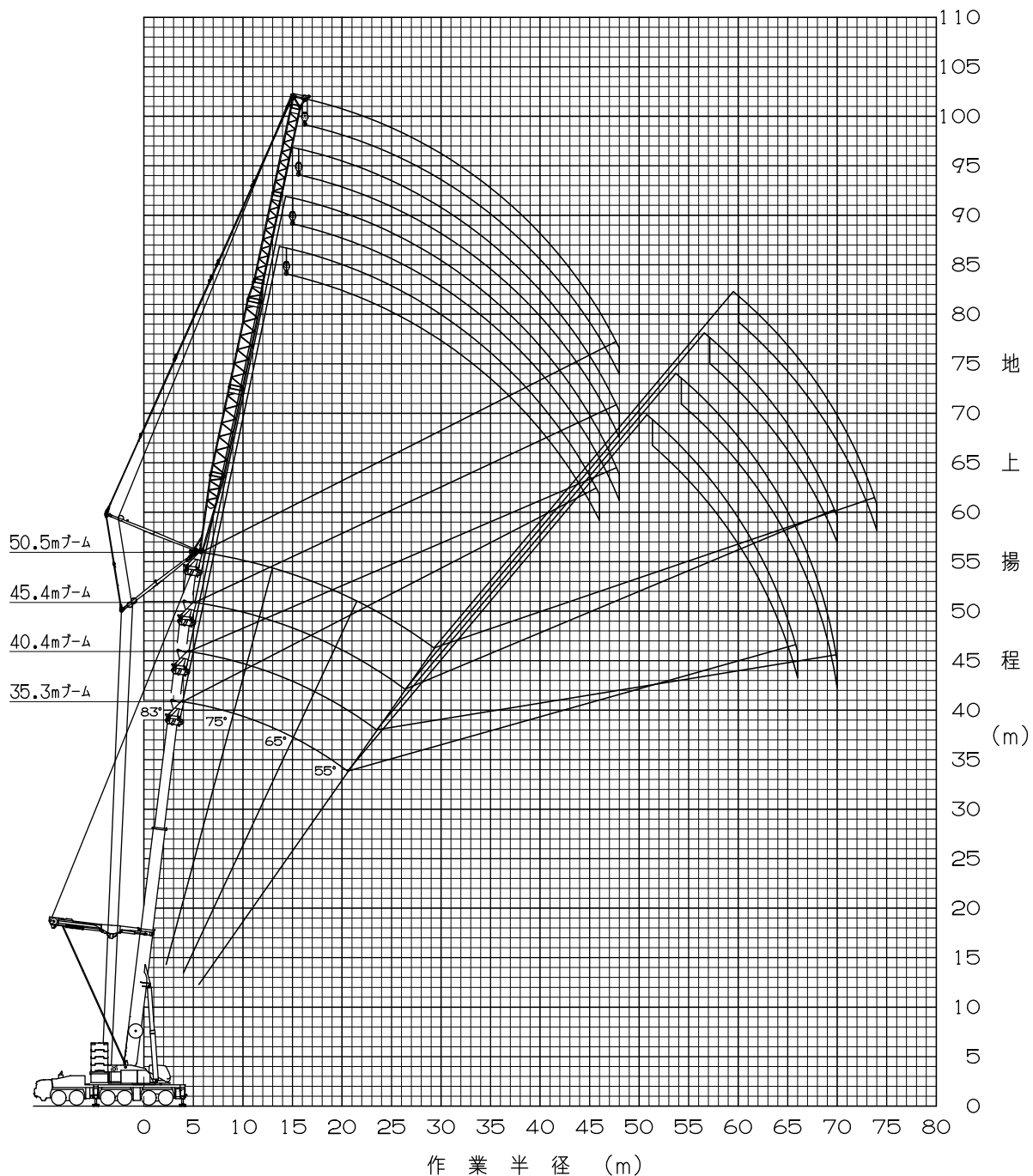

注意

- ◆ 上図はブームおよびジブのたわみを含んでいません。
- ◆ TLA性能の最大作業半径を図示しています。

〔T R A + 2.1m + 47m ラフィングジブ + 9m エクステンションジブ〕

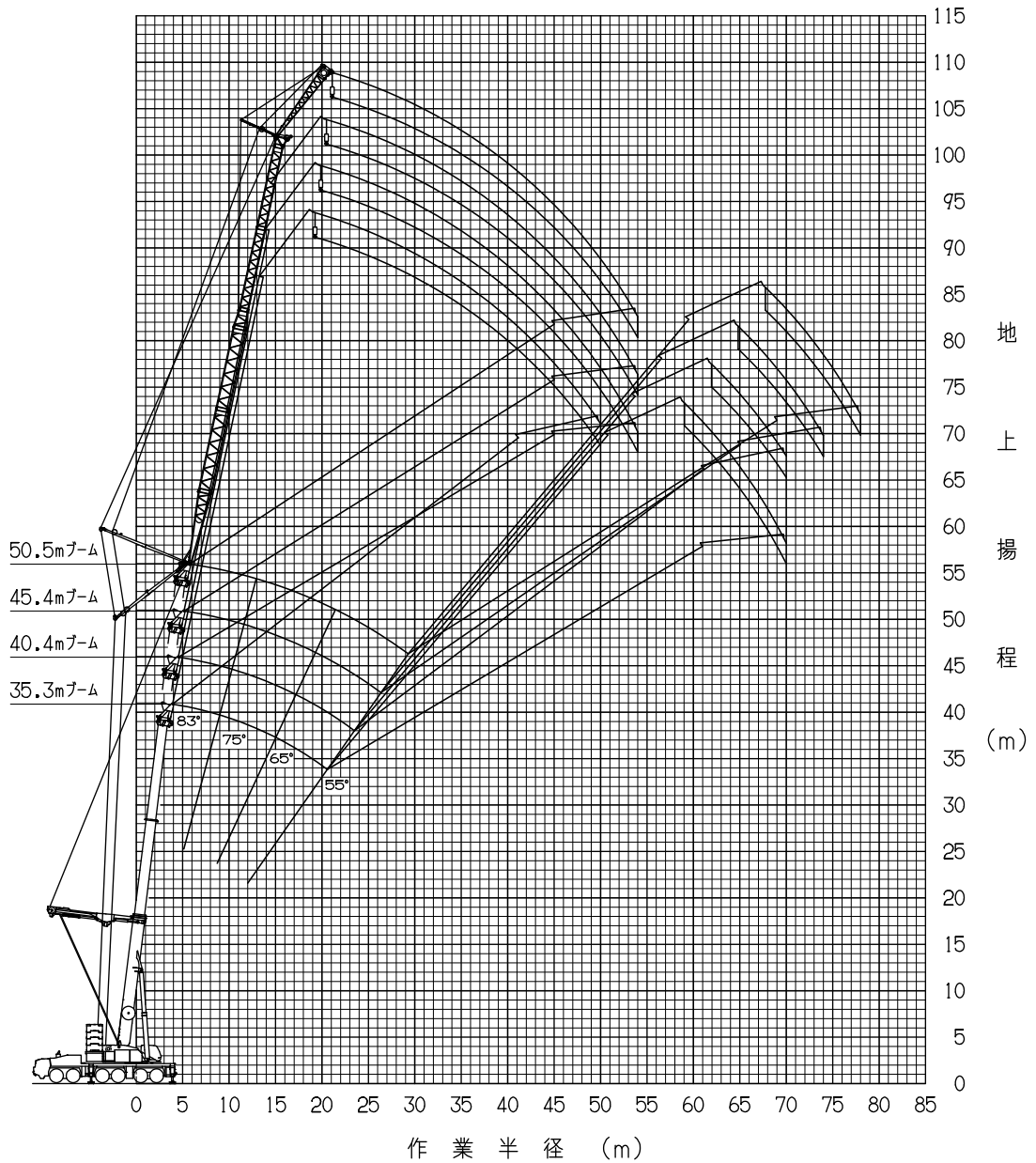

注意

- ◆ 上図はブームおよびジブのたわみを含んでいません。
- ◆ T L A 性能の最大作業半径を図示しています。

[T R A + 2.1 m + 47 m ラフィングジブ + 17 m エクステンションジブ]

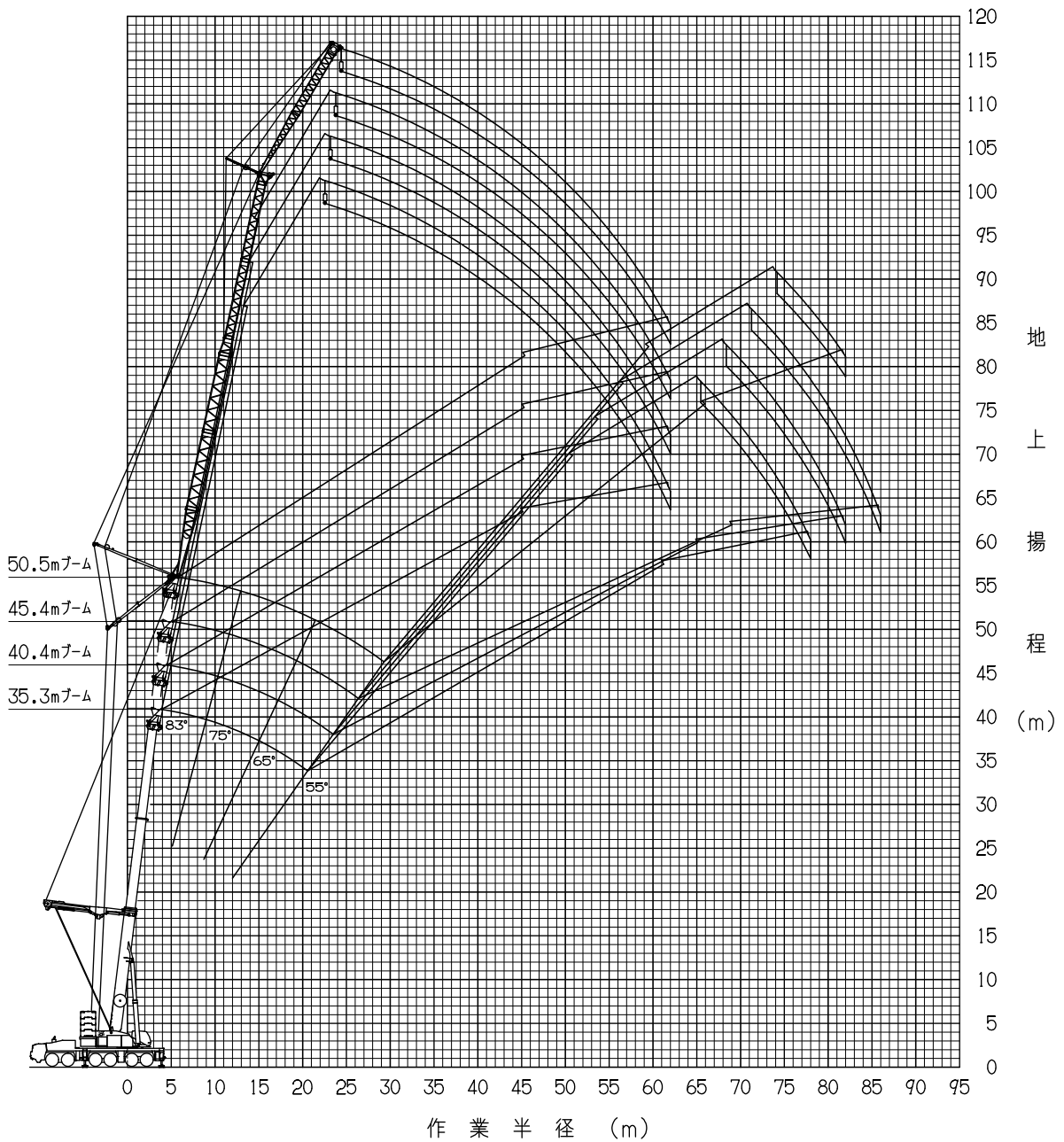

注意

- ◆ 上図はブームおよびジブのたわみを含んでいません。
- ◆ T L A 性能の最大作業半径を図示しています。

[T R A + 2.1 m + 47 m ラフィングジブ + 25 m エクステンションジブ]

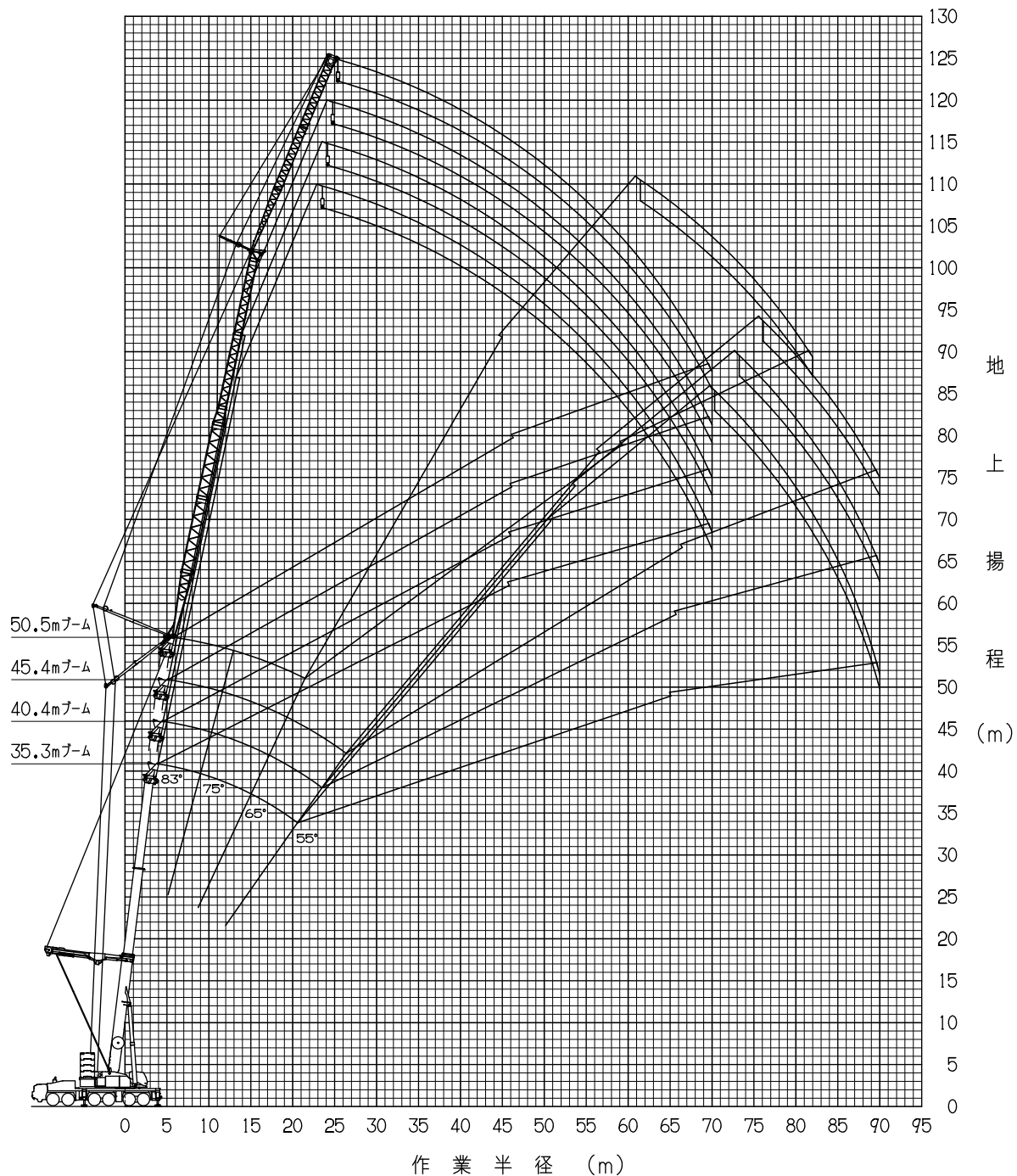

注意

- ◆ 上図はブームおよびジブのたわみを含んでいません。
- ◆ T L A 性能の最大作業半径を図示しています。

1 1 外 観 図

〔クレーン用台車〕

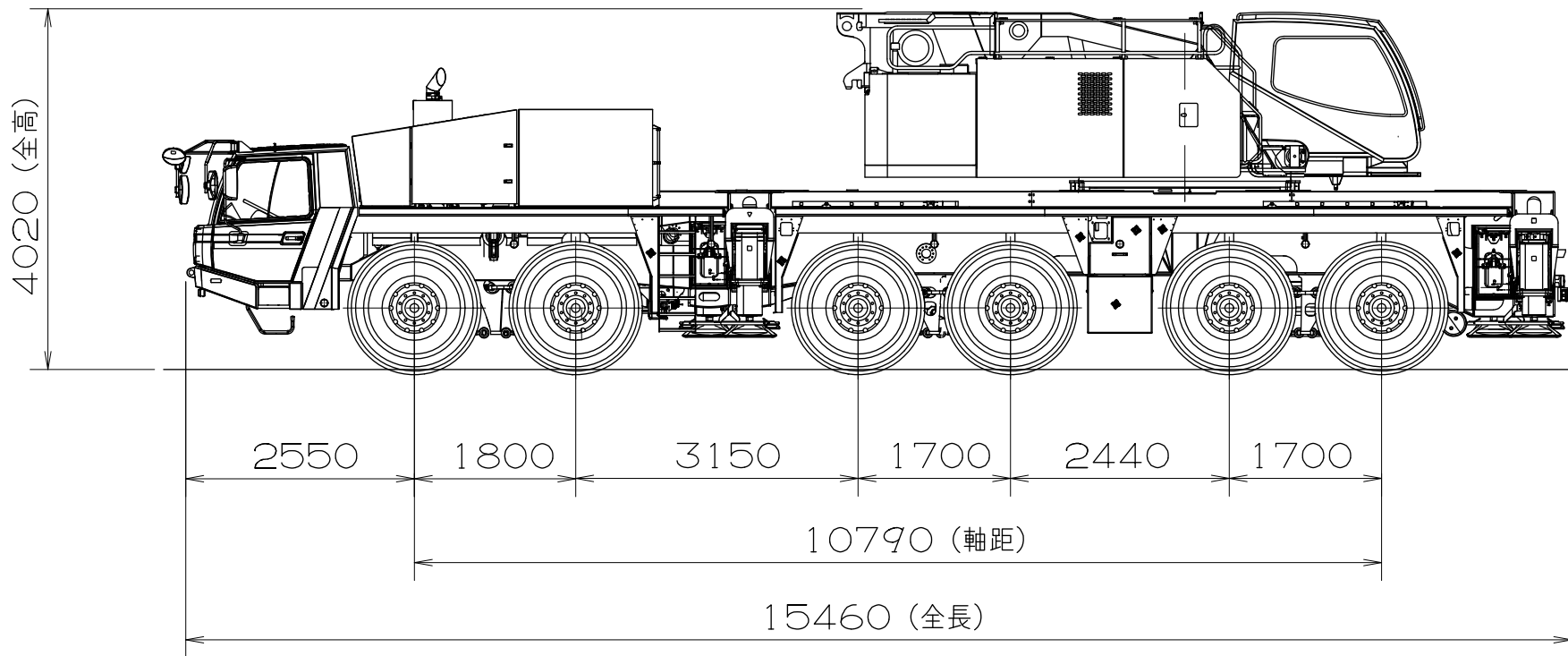
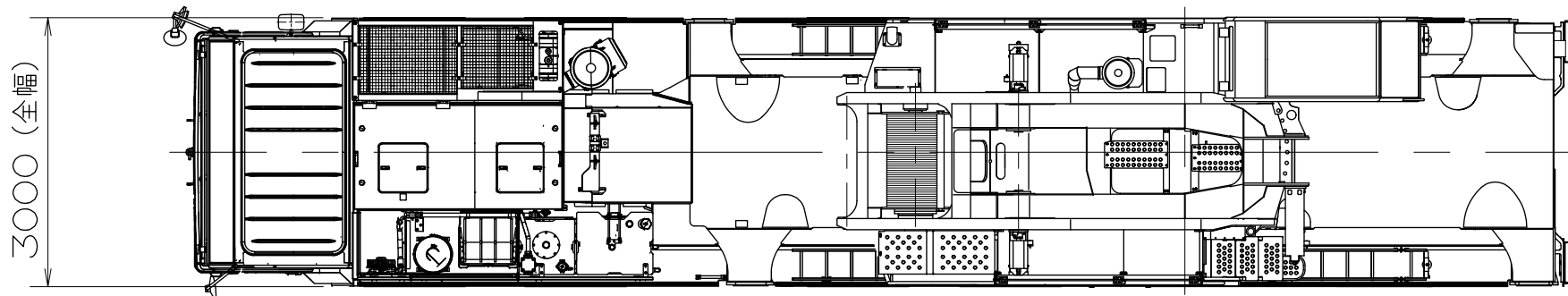

[構内移動状態]

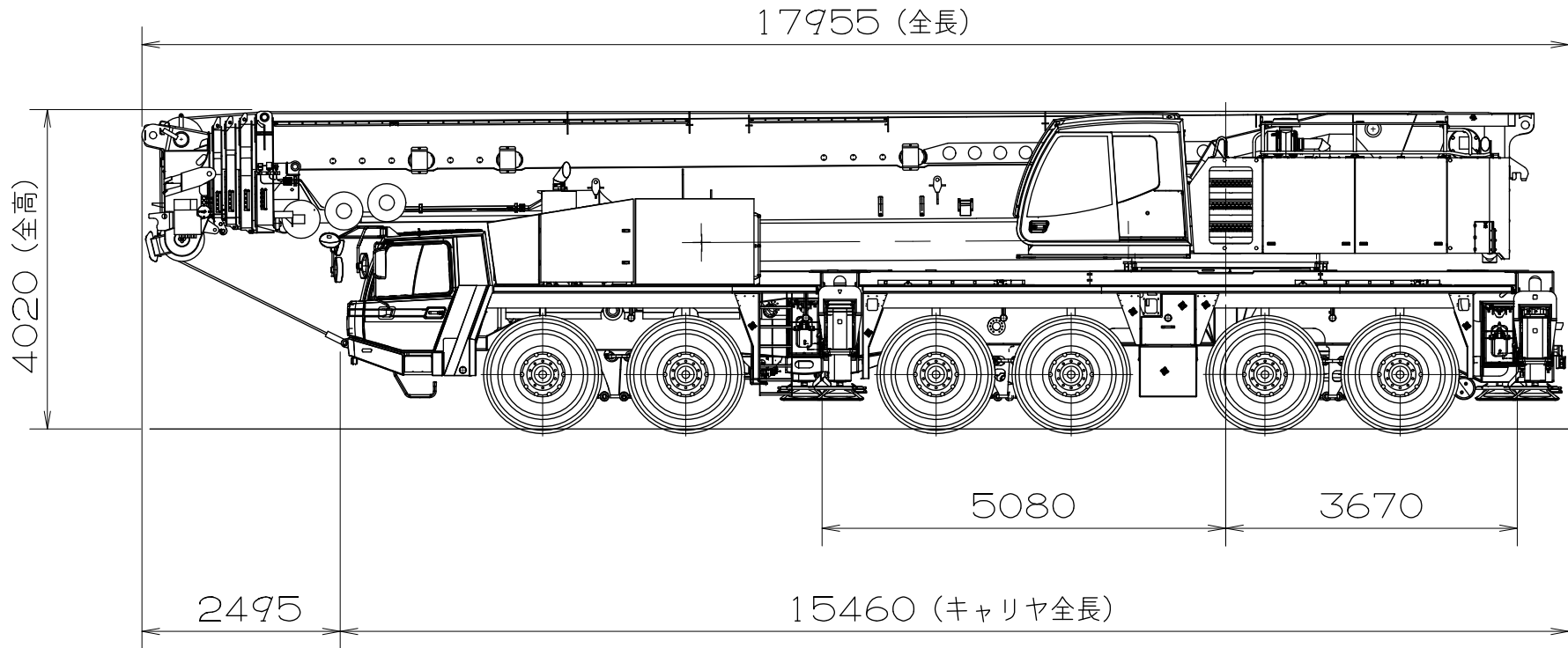
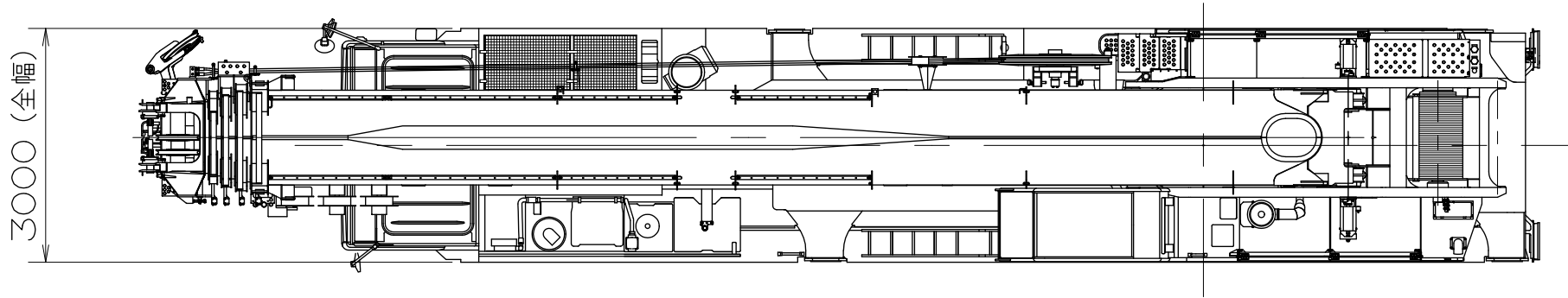

[TRA付 構内移動状態]

